

ENGLISH/FRENCH

'88

THE FINEST RADIO  
CONTROLLED MODELS

CATALOG

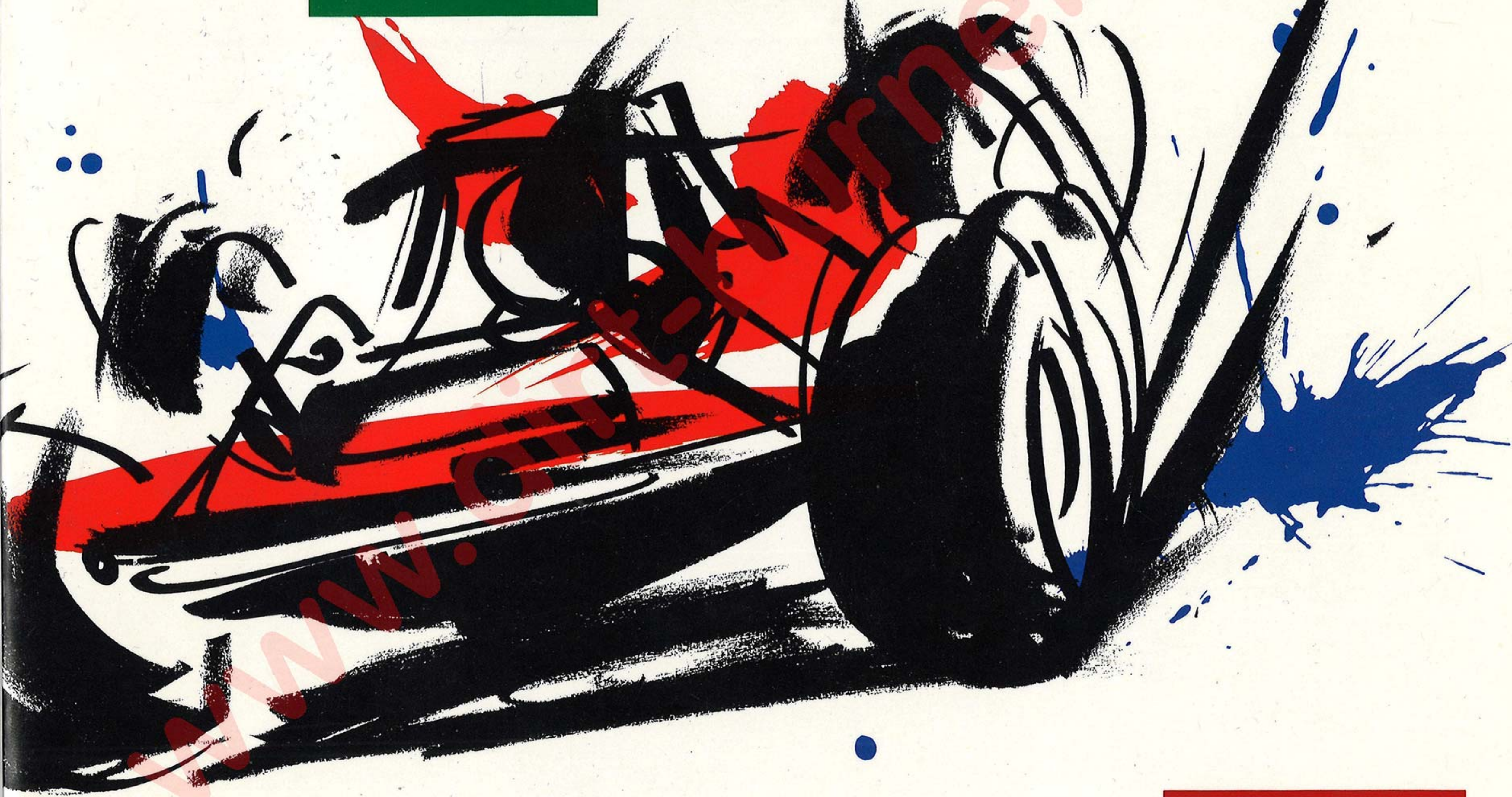

**KYOSHO**  
THE FINEST RADIO CONTROL MODELS









# THE WINNERS

TEAM KYOSHO INTERNATIONAL





# INDEX



## ELECTRIC VEHICLES / MOTORCYCLE

HONDA NSR 500 .....	8
BAJA-BUGS .....	10
BIG BRUTE .....	18
RAIDER 2WD .....	20
PEGASUS .....	23
COSMO .....	24
ICARUS .....	25
ULTIMA .....	26
SHADOW 4WD .....	32
OPTIMA PRO 4WD.....	34
OPTIMA MID .....	36
TURBO OPTIMA MID.....	38
OPTIMA .....	40
JAVELIN .....	40
ROCKY 4WD .....	42
GALLOP MKII.....	44
TURBO ROCKY .....	48
TURBO OPTIMA .....	48
SALUTE.....	48
HONDA CR-X .....	52
PEUGEOT 205.....	52
PLAZMA MKIII KS-2 .....	54
PLAZMA MKIII LIMITED .....	55
FANTOM EXT CRC-II .....	56
FANTOM EXT BW-SPIDER .....	56
THE BIZZARD .....	58



## GAS VEHICLES

NITRO BRUTE .....	18
RACING PAJERO .....	62
RACING MONTERO .....	62
STINGER 4WD.....	64
STINGER MKII .....	65
ASSAULT .....	66
VANNING .....	67
PRESTO .....	67
BURNS 4WD .....	68
FANTOM 21-4IS .....	70

## ELECTRIC PLANES

PETIT DREAMIN 850 .....	74
PETIT BALLAD 900 .....	75
PETIT ROBIN 850 .....	75
PETIT BREEZIN 1200.....	75
FLASH EP .....	78
VALENCIA 1800 .....	80
ETUDE 1200 .....	81
DUET 1200 .....	82
EP ZERO FIGHTER.....	83
MELODY 1500 .....	85
MELODY MOTOR PYLON .....	86
LS-6 .....	87
LS-4 .....	87





#### GAS PLANES

049 TYPHOON.....	90
049 SKY RALLY .....	91
049 CESSNA 182 SKYLANE.....	92
WING MASTER 10 .....	93
PATRICIA 10.....	94
09 ZERO FIGHTER.....	95
PRELUDE 10.....	96
PRELUDE 20 .....	96
CESSNA SKYHAWK 172 .....	97
BELANCA SUPER DECATHLON .....	97
ACROSKY .....	100
CESSNA 188 AGWAGON .....	101
FA-200 AERO SUBARU .....	101
RV-3 HOMEBUILT .....	101
PROUD BIRD .....	101
MISS AMERICA .....	101
SUPER CHIPMUNK .....	101
TOMMY CAT .....	102
COSMO JET TRAINER .....	103
CAP 21.....	105
HUMMING 40.....	106
PLANET 40.....	107



#### BOATS/YACHTS

TOM'S RIVER .....	110
FLORIDA .....	111
CASABLANCA.....	112
RIVIERA .....	113
FAIRWIND .....	114

#### MISC

NiCd BATTERIES .....	117
CHARGERS .....	118
MOTORS.....	120
MOTOR CHECKER .....	122
MOTOR BREAK-IN MACHINE .....	122
OPTION HOUSE PARTS .....	123
OPTION PARTS.....	126
SOLDERING IRON / HANDY IRON .....	130
POLYCA COLOR PAINT .....	131
HOBBY SHEARS & SANDER .....	131
MICRON LINE TAPE .....	131
POWER DIVIDER .....	132
BLITZ STARTER .....	132
GLOW ENGINE STARTER PACK .....	133
K & B GLOW FUEL/PLUGS .....	134
EXCELCOTE COVERING FILMS.....	135
SILKYCOTE COVERING MATERIALS .....	136
K & B PAINTS/COATING POXY .....	137
SPECIAL PROP DRIVE UNITS .....	138
RADIO CONTROL UNITS.....	139
RACEWAY KIT.....	12
KYOSHO ORIGINALS .....	141
VIDEO TAPES .....	141



# MOTORCYCLE & BAJA BUGS

- HONDA NSR 500 ■ BAJA BUGS / ULTIMA
- BAJA BUGS / TURBO OPTIMA 2WD
- BAJA BUGS / SALUTE 2WD

[www.dirt-bourners.com](http://www.dirt-bourners.com)









#### MOTORCYCLE REALISM IN MINIATURE!

CAPTURE THE THRILLS OF GRAND PRIX MOTORCYCLE RACING WITH THIS REALISTIC MODEL OF THE ROTHMANS HONDA NSR500! POWERFUL PERFORMANCE WITH THE LeMANS DM20 MOTOR (INCLUDED) AND A LIGHTWEIGHT 7.2V NiCd BATTERY PACK (NOT INCLUDED). THE "500" LEANS REALISTICALLY AS IT BLASTS THROUGH THE "ESSES" AND ANY OTHER CURVES YOU WANT TO POWER IT THROUGH! THE UNIQUE GYRO-STEERING SYSTEM MAKES IT EASY TO OPERATE, EVEN FOR BEGINNERS. REAL CHAIN DRIVE. (THREE GEAR RATIOS FOR ALL COURSES.) STRONG FIBERGLASS-REINFORCED ABS MONOCOQUE FRAME. POLYCARBONATE AND REINFORCED NYLON FAIRING, TANK AND SEAT PARTS.

#### REQUIRED FOR OPERATION (NOT INCLUDED IN KIT)/SUGGESTED FOR BEST APPEARANCE

- 2-CHANNEL RADIO CONTROL SET WITH SERVOS FOR MINIATURE CARS AND ELECTRONIC SPEED CONTROLLER
- 7.2V-270mAh NiCd BATTERY AND CHARGER

#### Technical Data

①Length/257mm(10.1in)②Width/66mm(2.6in)③Height/150mm(5.9in)④Wheelbase/175mm(6.8in)⑤Tires/(F)78φ×18mm(3.1×0.7in);(R)86φ×22mm(3.4×0.87in)⑥Total Weight/680g(24.0oz)⑦Gear Ratio/13.8:1-19.3:1⑧Motor/Le Mans DM20(Included)⑨Battery/7.2V-270mAh(Not included)⑩Radio/2-Channel(Not included)

#### Technische Daten

①Longueur②Largeur③Hauteur④Empattement⑤Roue⑥Poids Total⑦Proportion Dembrayage⑧Moteur⑨Nicad

#### LE RÉALISME DE LA MOTO EN MINIATURE!

VIVEZ L'EXCITATION DES GRAND PRIX AVEC CE MODÈLE RÉALISTE DE LA HONDA NSR500 ROTHMANS! MACHINE PERFORMANTE GRÂCE AU PUISSANT MOTEUR LeMANS DM20 (INCLUS) ET LA BATTERIE LÉGÈRE 7,2V (NON COMPRISE). LA HONDA 500 SE COUCHE DANS LES CHICANES COMME DANS LES VIRAGES PROLONGÉS. LE PILOTAGE DE LA MACHINE EST FACILITÉ PAR L'APPLICATION D'UN GYROSCOPE DE DIRECTION ET EST À LA PORTÉE DU DÉBUTANT. TRANSMISSION À TROIS RAPPORTS PAR CHAÎNE. CHÂSSIS RÉSISTANT, EN ABS RENFORCÉ À LA FIBRE DE VERRE. CARROSSAGES, SELLE ET RÉSERVOIR EN POLYCARBONATE ET EN NYLON RENFORCÉ.

#### ACCESSOIRES NON COMPRIS. DÉCORATION SUGGÉRÉE

- ENSEMBLE RADIO DEUX VOIES AVEC SERVO MINIATURE ET VARIATEUR ÉLECTRONIQUE
- BATTERIE NiCad 7,2V-270mAh ET CHARGEUR
- PEINTURE POLYCA



**GRAND PRIX RACER "HONDA NSR 500,"  
ELECTRIC POWERED MOTORCYCLE**

**1:8 SCALE**  
NO.3002 • 7800

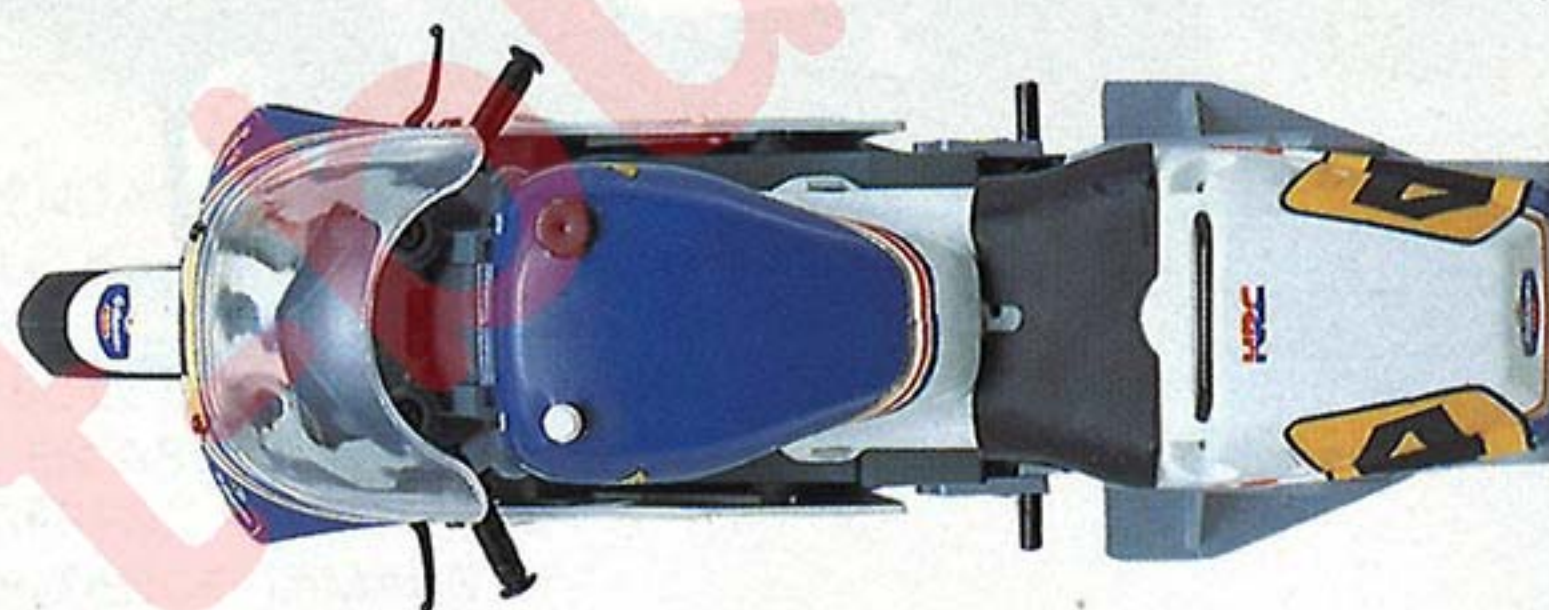
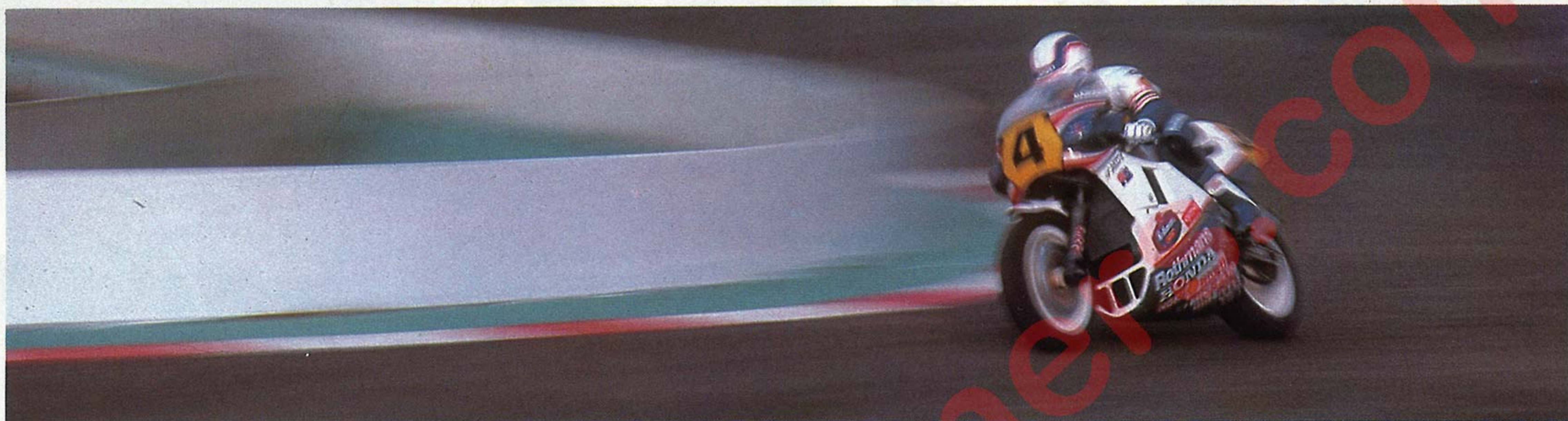

TUBELESS SEMI-PNEUMATIC SYNTHETIC RUBBER TIRES. GYRO-STEERING FRONT WHEEL UNIT.

PNEUS TUBELESS SEMI-PNEUMATIQUES EN CAOUTCHOUC SYNTHÉTIQUE.



FUNCTIONING FRONT SUSPENSION WITH INTERNAL SPRINGS. REALISTIC ACTION.

SUSPENSION AV EFFICACE ET RÉALISTE PAR RESSORT INTERNE.



DRIVE TO REAR WHEEL BY REAL ROLLER CHAIN. REALISTIC SLICK RACING TIRES.

TRANSMISSION DE LA ROUE AR PAR CHAÎNE. PNEUS DE VITESSE DU TYPE SLICK.



RIGID MONOCOQUE FRAME SUPPORTS SUSPENSION AND RUNNING GEAR, AIDS EASY ASSEMBLY.

ASSEMBLAGE FACILE GRÂCE AU CHÂSSIS MONOCOQUE RIGIDE QUI SOUTIEN LA SUSPENSION ET LA TRANSMISSION.



POWERFUL 7.2V-270mAh NiCd BATTERY (NOT INCLUDED) CLIPS UNDER CHASSIS FOR LOW CG.

BATTERIE PUISSANTE 7,2V- .270mAh (NON COMPRISE), INSTALLÉE SOUS LE CHÂSSIS EN VUE DE SURBAISSER LE CENTRE DE GRAVITÉ.





#### THE MOST MODELLING FUN OF 1987!

WHAT'S SMALL, FAST, EXCITING AND FUN? THE NEW 1/20-SCALE "BAJA BUGS" MINI OFF-ROADERS! SUPER QUICK AND SUPER NIMBLE! PUSH THE "GO" STICK AND THEY'RE GONE! WITH A FULLY FUNCTIONING FOUR-WHEEL INDEPENDENT SUSPENSION (DOUBLE WISH-BONES) AND A 7.2V-270mAh NiCd BATTERY FOR POWER, THESE LITTLE BUGS SCOOT AROUND A COURSE ALMOST AS FAST AS ORDINARY 1/10-SCALE MODELS. BECAUSE OF THEIR SMALL SIZE THEY CAN BE RUN INDOORS AND IN OTHER RESTRICTED SPACES.

#### REQUIRED FOR OPERATION/RECOMMENDED FOR BEST APPEARANCE

● RADIO CONTROL SET (2-CHANNEL) ● POLYCA COLOR PAINT ● MICRONLINE STRIPPING TAPE

#### Technical Data

① Length/200mm(7.9in) ② Width/110mm(4.3in) ③ Height/67mm(2.6in) ④ Wheelbase/132mm(5.2in) ⑤ Ground Clearance/18mm(0.7in) ⑥ Front Track/88mm(3.5in) ⑦ Rear Track/90mm(3.5in) ⑧ Tires/(F)38φ×12mm(1.5×0.5in);(R)44φ×20mm(1.7×0.8in) ⑨ Total Weight/350g(12.3oz) ⑩ Gear Ratio/10:1 ⑪ Motor/Le Mans DM20(Included) ⑫ Battery/7.2V-270mAh(Included) ⑬ Radio/2-Channel(Not included)

#### Technische Daten

① 長さ ② 幅 ③ 高さ ④ 軸間 ⑤ 床高 ⑥ 前軸間 ⑦ 後軸間 ⑧ タイヤ ⑨ 総重量 ⑩ 歯数比 ⑪ モーター ⑫ ニカド

#### LA PLUS GRANDE JOIE EN MODÉLISME DE 1988!

QU'EST-CE QUI EST PETIT, RAPIDE, EXCITANT ET AMUSANT? LES NOUVELLES MINI 'BAJA BUGS' TOUS-TERRAINS À L'ÉCHELLE 1/20. EXTRÊMEMENT RAPIDES ET SUPER NERVEUSES! METTEZ LES GAZ ET ELLES S'ÉLANCENT COMME DES BOLIDES! SUSPENSION INDÉPENDANTE À DOUBLE BRAS SUR LES 4 ROUES. PROPULSÉES PAR UN ACCU DE 7,2V-270mAh, CES PETITES VOITURES PARCOURENT LE CIRCUIT PRESQU'AUSI VITE QUE LES MODÈLES 1/10. CES PETITES MERVEILLES SONT AUSSI EXCEPTIONNELLES À L'INTÉRIEUR ET SUR LES PETITES SURFACES, GRÂCE À LEUR TAILLE RÉDUITE.

#### ACCESSOIRES REQUIS ET DÉCORATION SUGGÉRÉE

● ENSEMBLE DE RADIO À 2 VOIES ● PEINTURES POLYCA ● RUBANS DE DÉCORATION MICRONLINE ●



# BAJA-BUGS

ELECTRIC POWERED OFF-ROADER

"TURBO OPTIMA 2WD,, NO.3191

"ULTIMA,, NO.3192

"SALUTE 2WD,, NO.3193

1:20 SCALE

● 9800



- 1 EFFECTIVE, LIGHTWEIGHT ALUMINUM FRICTION-TYPE SHOCK ABSORBERS.
- 2 STRONG, LIGHT ABS RADIO PLATE.
- 3 STRONG, LIGHT ALUMINUM HALF-SHAFTS.
- 4 COMBINED GEARBOX/DIFFERENTIAL WITH CLOSE-MOUNTED MOTOR.
- 5 LOW-PROFILE, HIGH-GRIP SEMI-PNEUMATIC TIRES. SPIKE REAR/RIB-TYPE FRONT.
- 6 WISHBONE/PARALLEL ARM INDEPENDENT SUSPENSION FRONT/REAR.
- 7 HIGH-POWER 7.2V-270mAh NiCd BATTERY (INCLUDED, WITH CHARGER).
- 8 STYLISH, STRONG AND LIGHT ONE-PIECE ABS WHEELS.
- 9 CUSTOM HIGH-PERFORMANCE LeMANS DM20 MOTOR (INCLUDED).
- 10 NYLON MOTOR GUARD.

1. AMORTISSEURS À FRICTION EFFICACES EN ALUMINIUM LÉGER.
2. PLAQUE-RADIO RÉSISTANTE EN ABS LÉGER.
3. AXES SOLIDES EN ALUMINIUM LÉGER.
4. ENGRENAGE DIFFÉRENTIEL COMBINÉ À PROXIMITÉ DIRECTE DU MOTEUR.
5. PNEUS PROFIL BAS RAINURÉS À L'AVANT, PNEUS À POINTES À L'ARRIÈRE.
6. SUSPENSIONS INDÉPENDANTES AUX 4 ROUES BRAS PARALLÈLES.
7. PUISSANTE BATTERIE Ni-Cad 7,2V-270mAh (COMPRIS AVEC LE CHARGEUR).
8. JANTES INTÉGRALES EN ABS, ÉLÉGAN- TES, SOLIDES ET LÉGÈRES.
9. MOTEUR DE PERFORMANCE LeMANS DM20 (COMPRIS).
10. PROTECTION DU MOTEUR EN NYLON.

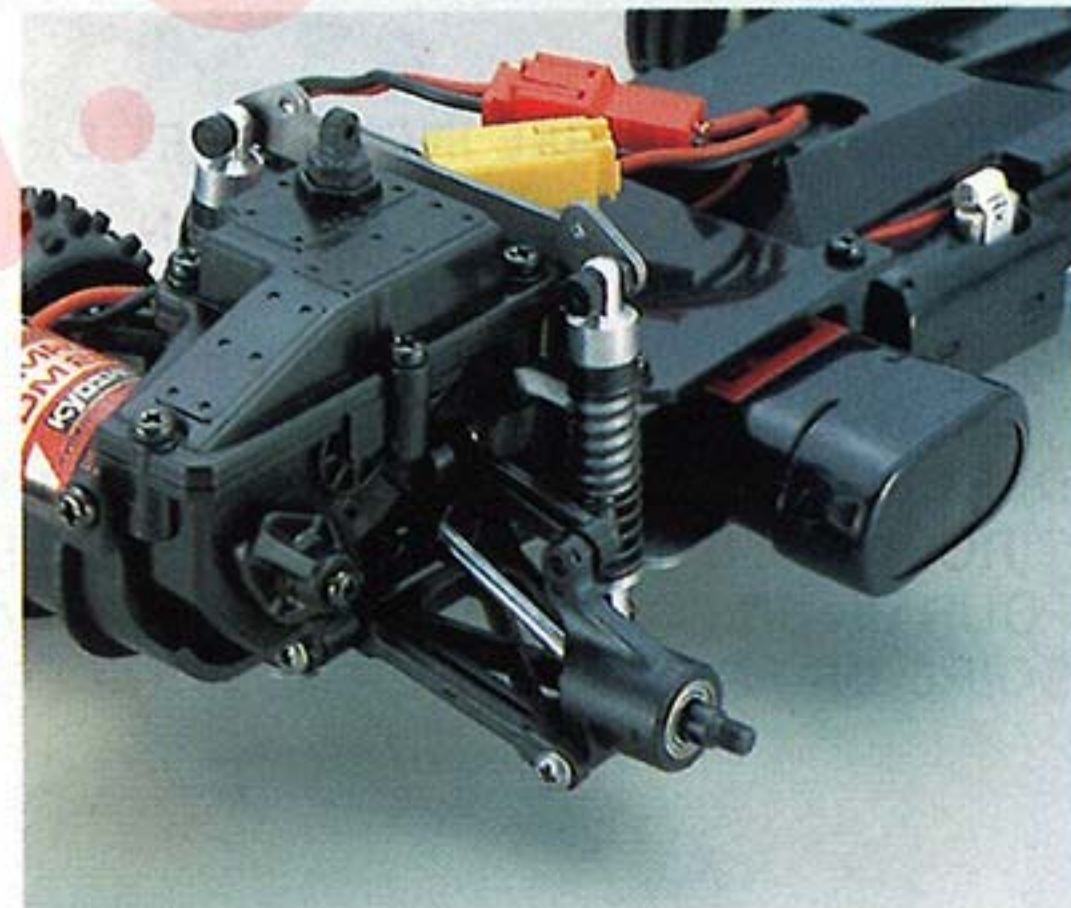
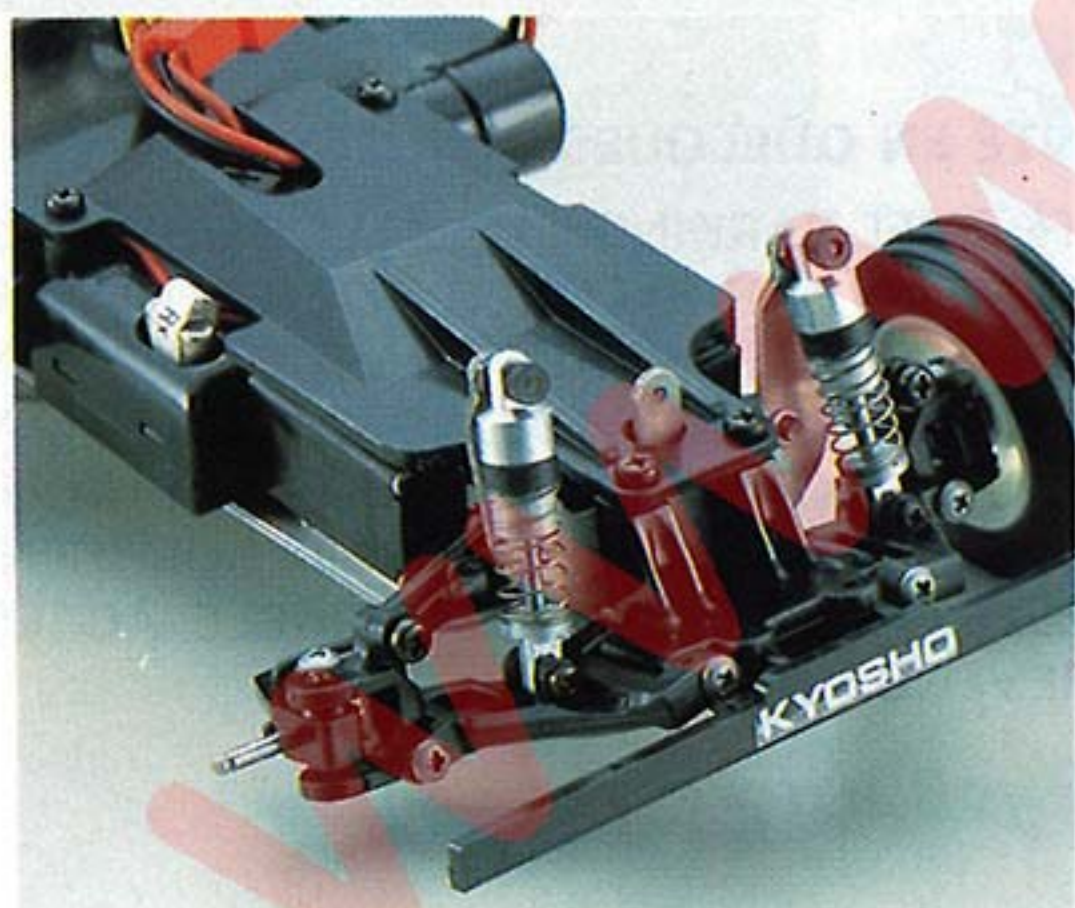
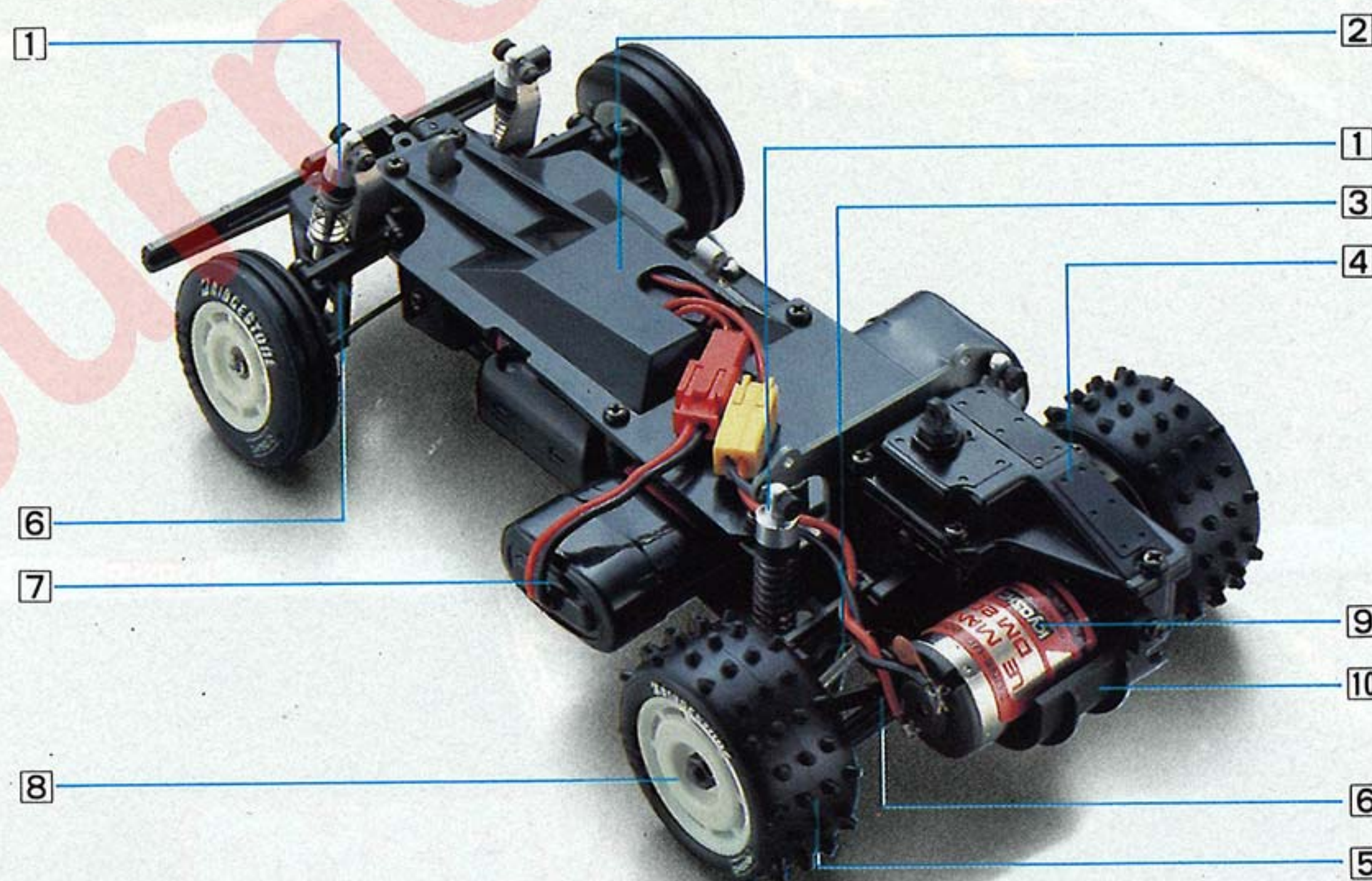

WISHBONE/PARALLEL ARM INDEPENDENT SUSPENSION FRONT/REAR FOR TOP ROADHOLDING. ALUMINUM-BODY FRICTION-TYPE SHOCK ABSORBERS ON ALL WHEELS. ALUMINUM HALF-SHAFTS.

SUSPENSION AV ET AR INDÉPENDANTE À BRAS PARALLÈLES EN VUE D'UNE PARFAITE TENUE DE ROUTE. AMORTISSEURS À FRICTION EN ALUMINIUM SUR LES QUATRE ROUES ET DEMIS-AXES EN ALUMINIUM.

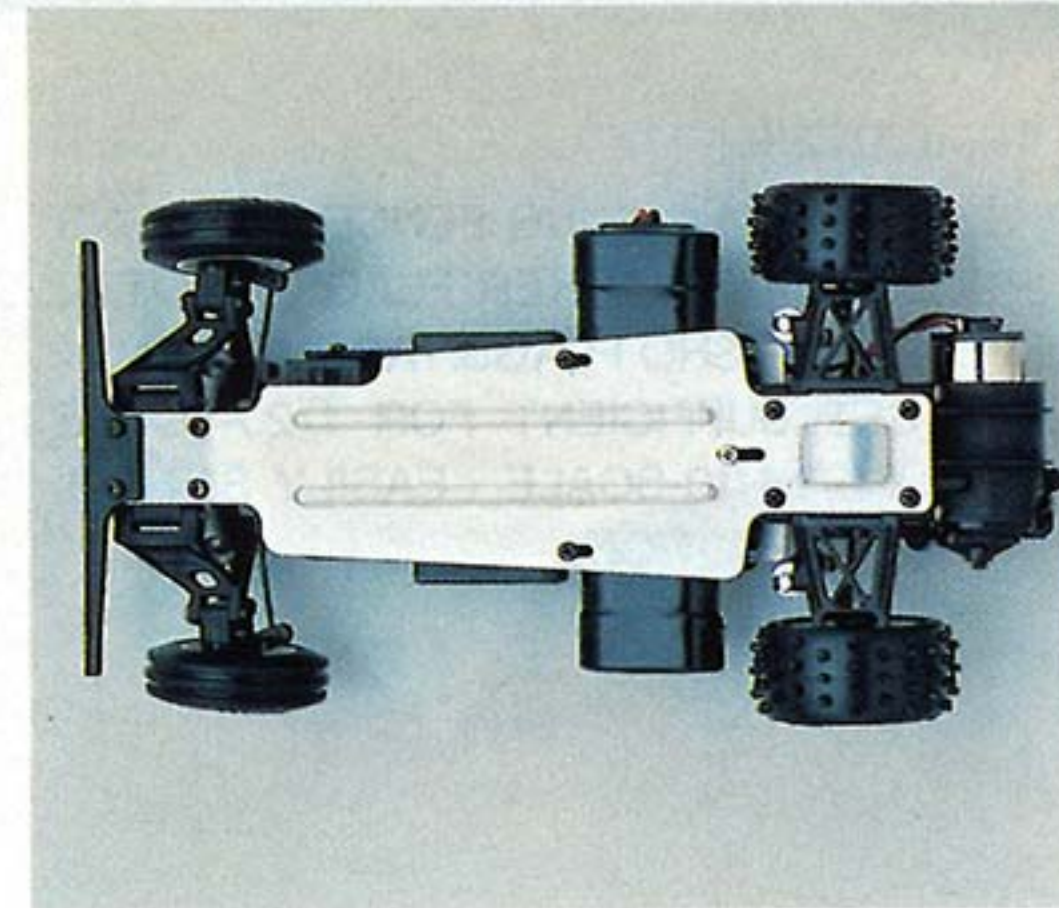

STRONG, LIGHT ABS RADIO PLATE. RIGID ALUMINUM CHASSIS PROTECTS RADIO EQUIPMENT, BATTERY.

PLAQUE-RADIO SOLIDE EN ABS LÉGER. CHÂSSIS RIGIDE EN ALUMINIUM PROTÉGEANT LA RADIO ET LA BATTERIE.



HIGH-POWER 7.2V-270mAh NiCd BATTERY INCLUDED, WITH CHARGER.

BATTERIE PUISSANTE 7,2V-270mAh COMPRIS, AINSI QUE LE CHARGEUR.





#### INSTANT RACE COURSE! SET UP AND TAKE DOWN IN MINUTES!

SET UP A RACE COURSE IN ANY PARKING LOT OR GYM! INTERLOCKING FENCE SECTIONS EASILY SET UP USING STABLE SUPPORT POLES. (POLES HOLD MARKER FLAGS). TOTAL LENGTH: 36m (3 DIFFERENT LENGTHS). INCLUDES JUMP, 20 KYOSHO FLAGS, ABOVE-TRACK STARTING LINE BANNER, CHECKERED FLAGS. ONE SET SUFFICIENT FOR 1/20-SCALE COURSE (5m x 8m MINIMUM REQUIRED); USE TWO SETS FOR 1/10-SCALE. EASILY SET UP, DISMANTLED, DURABLE. COLORFUL IDEAL FOR DEALER PROMOTION.

#### CIRCUIT DE COURSE INSTALLÉ ET DÉMONTÉ EN QUELQUES MINUTES!

INSTALLEZ VOTRE CIRCUIT SUR N'IMPORTE QUEL PARKING OU SALLE DE SPORTS! SECTIONS EMBOÎTABLES, FACILES À INSTALLER PAR PYLÔNES INTERMÉDIAIRES (SUPPORTANT LES FANIONS DE REPÈRES). LONGUEUR TOTALE 36 MÈTRES (3 LONGUEURS DISPONIBLES) COMPRENANT UN TREMPLIN, 20 FANIONS KYOSHO, BANDEROLE DE DÉPART, FANIONS QUADRILLÉS. LE KIT COMPLET SUFFIT POUR UN CIRCUIT 1/20° (SURFACE REQUISE DE 5x8 MÈTRES). DEUX ENSEMBLES SUFFISENT POUR UN CIRCUIT 1/10°. FACILE À INSTALLER ET À DÉMONTÉ, ET DURABLE. ACCESSOIRE DE PROMOTION IDÉAL POUR LES REVENDEURS.

#### Technical Data

●Contents: Fence sections: 1200mm/10pc; 900mm/20pc; 600mm/10pc ●Support poles/50pc. ●Jump/lpc. ●Kyosho flags/20pc. ●Checkered flags/2pc. ●Sponsor's sticker





- FENCE SECTIONS;  
1200mm/10pc;  
900mm/20pc;  
600mm/10pc;
- STARTING LINE BANNER BOARD

### CARACTÉRISTIQUES

L'ENSEMBLE COMPREND : ● DIX SECTIONS DE 1200mm, VINGT DE 900mm ET DIX DE 600mm ● 50 PYLÔNES  
● LE TREMPIN ● 20 FANIONS KYOSHO ● 2 FANIONS QUADRILLÉS ● LA BANDEROLE DE DÉPART ●

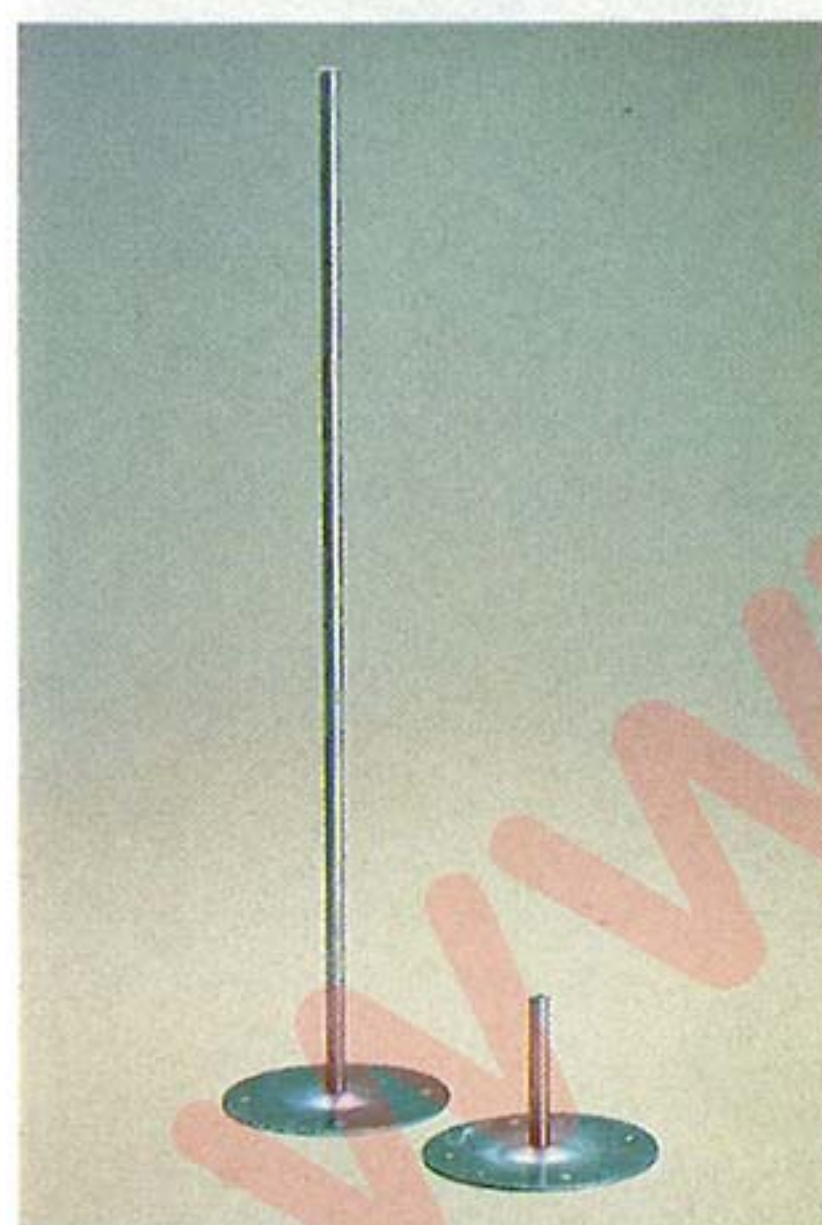

● SUPPORT POLES/50pc



● KYOSHO FLAGS/20pc  
● CHECKERED FLAGS/2pc



● JUMP/1pc



### ■ OPTION

START LIGHT NO.3199 ● 9800  
TIMED—SEQUENCE START LIGHT. REMOTE OPERATION POSSIBLE.



# OPTION PARTS

FOR BAJA-BUGS / HONDA NSR 500

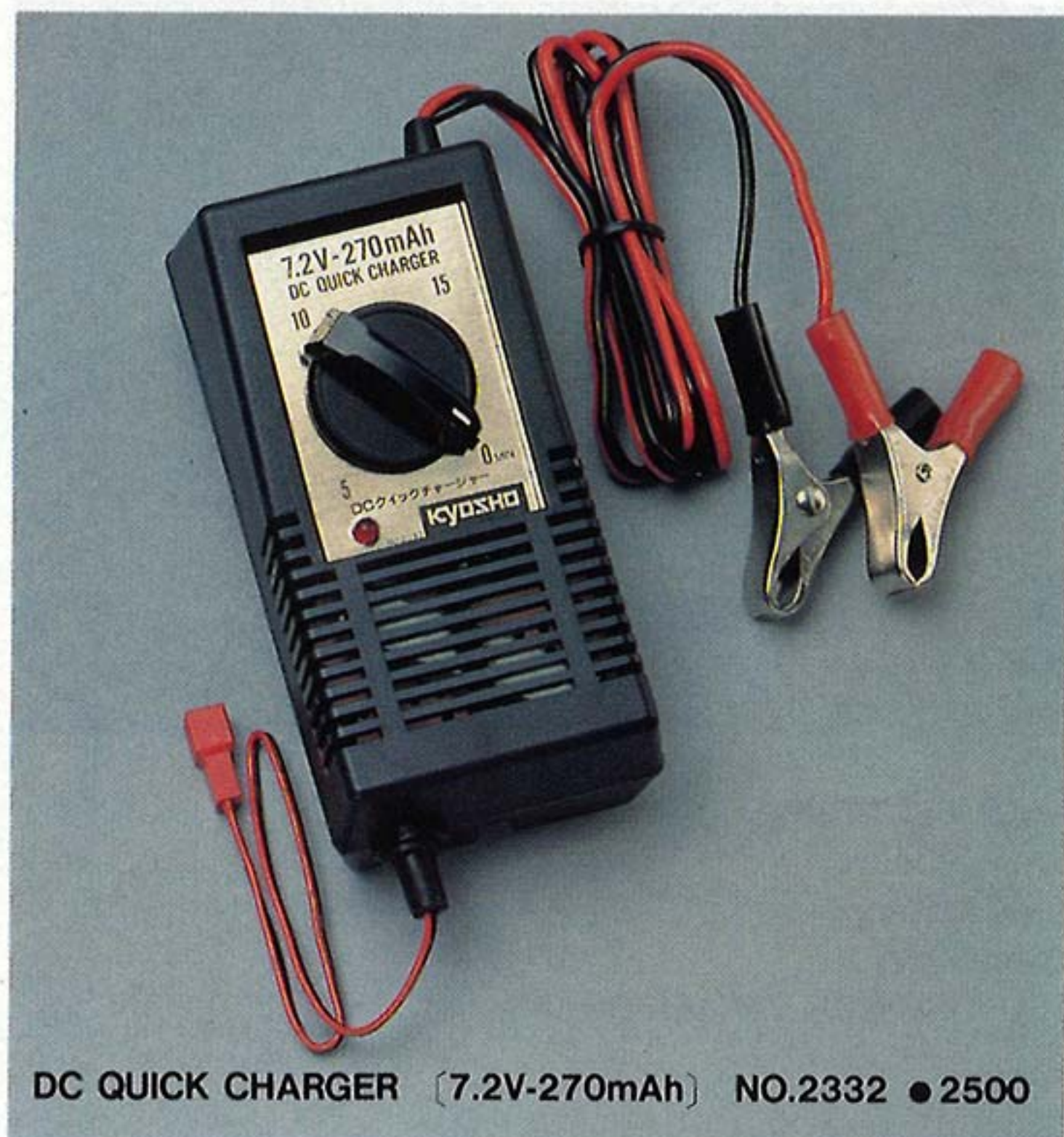

DC QUICK CHARGER [7.2V-270mAh] NO.2332 ● 2500

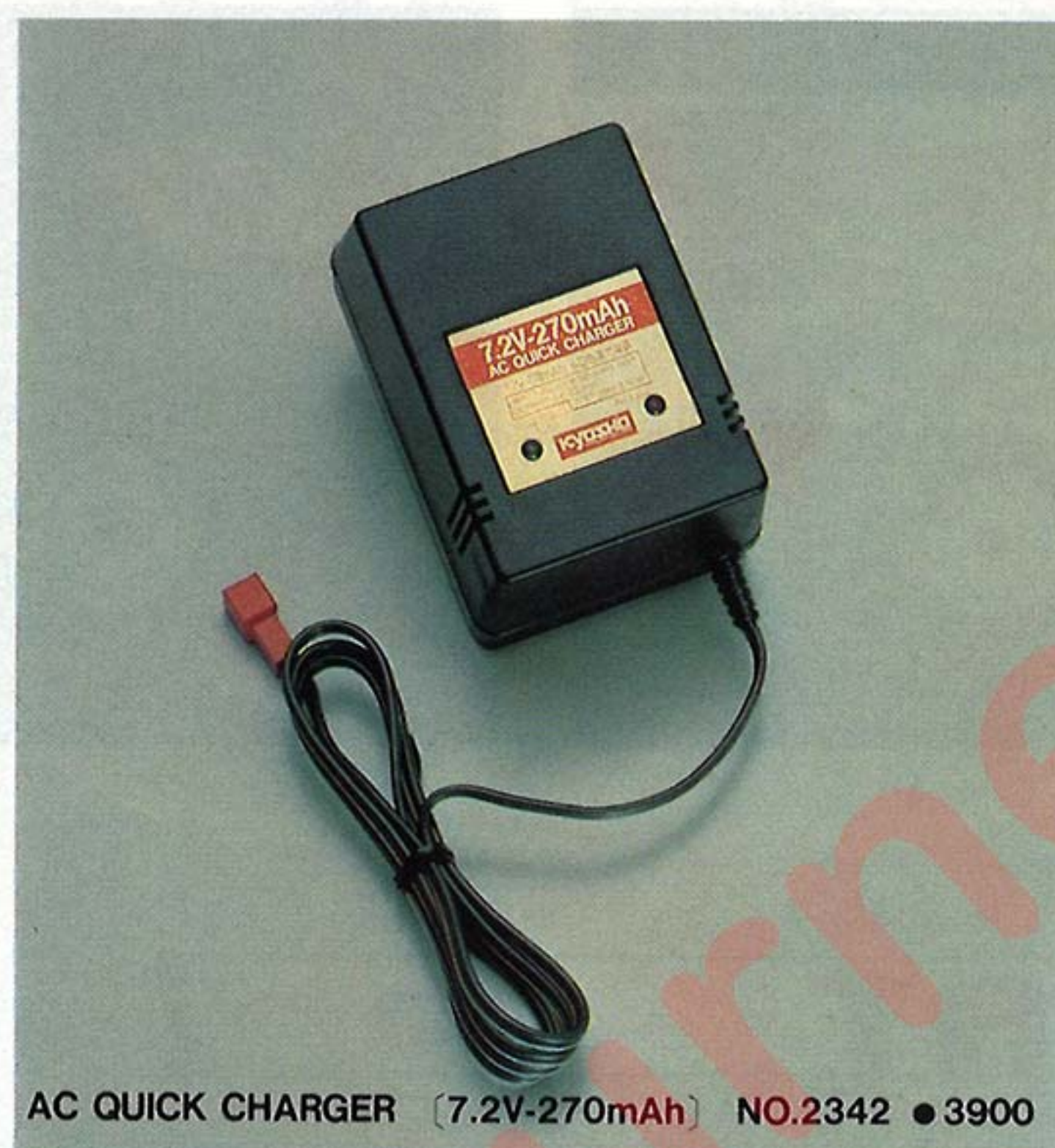

AC QUICK CHARGER [7.2V-270mAh] NO.2342 ● 3900



SPONGE TIRE (FOR BAJA-BUGS) DEW-2 ● 900  
A PAIR FOR EACH FRONT AND REAR



NO.2322 ● 1300  
AC CHARGER [7.2V-270mAh]



7.2V-270mAh NiCd BATTERY NO.2312 ● 2500



ALUMINUM WHEEL SET (FOR BAJA-BUGS) DEW-1 ● 1980  
A PAIR FOR EACH FRONT AND REAR



RACING MOTOR "LeMANS DMC20BB" NO.1935 ● 1500



BALL BEARING SET (FOR BAJA-BUGS) NO.1975 ● 4000



SOFT SPRING SET (FOR BAJA-BUGS) DEM-4 ● 200

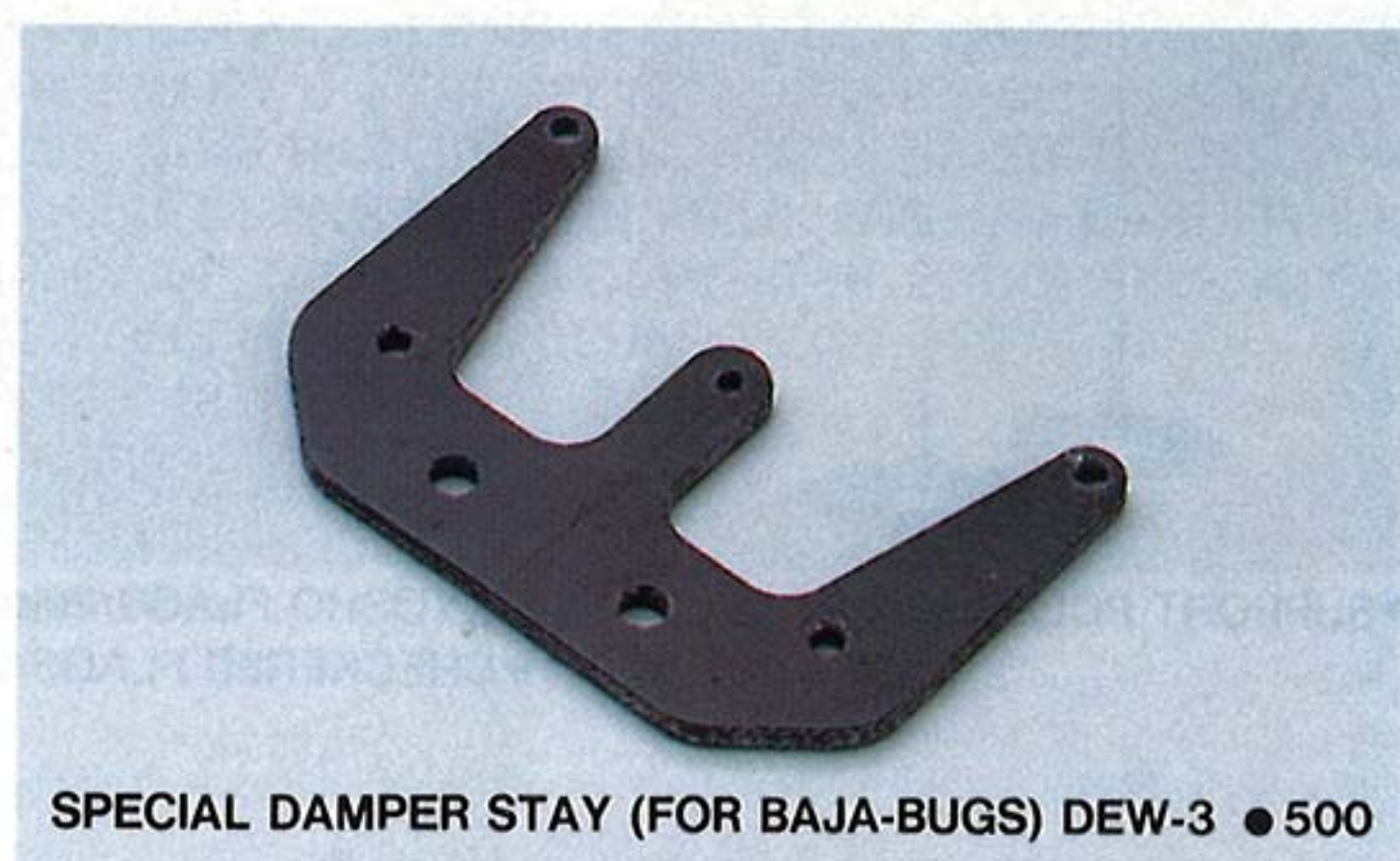

SPECIAL DAMPER STAY (FOR BAJA-BUGS) DEW-3 ● 500



■IMPULSE II [RS-V] NO.2546  
(FOR BAJA-BUGS)

■IMPULSE II [RS-M] NO.2547  
(FOR MOTORCYCLES)

COMFORTABLE TO HOLD, PRECISE IN CONTROL. THAT'S IMPULSE II ! IDEAL FOR MINIATURE ROAD MODELS. THIS TWO-CHANNEL SET INCLUDES MICRO SERVO AND ELECTRONIC SPEED CONTROLLER. HAS TRIMS AND SERVO REVERSING.

L'IMPULSE II EST UNE RADIO PRATIQUE ET PRÉCISE, ET IDÉAL POUR LES MODÈLES MINIATURES. CETTE RADIO À 2 VOIES COMPREND DEUX MICRO SERVO ET UN VARIATEUR ÉLECTRONIQUE. L'ÉMETTEUR EST POURVU DE TRIMS ET D'INVERSEURS DE SERVO.

■IMPULSE II



■PULSAR PRO 2000

■PULSAR EXP 2001

■PULSAR PRO 2000 [RS-V] NO.2557  
(FOR BAJA-BUGS)

■PULSAR PRO 2000 [RS-M] NO.2558  
(FOR MOTORCYCLES)

PULSAR PRO-2000 TWO-CHANNEL SET INCLUDES MICRO SERVO AND ELECTRONIC SPEED CONTROLLER. HAS TRIMS AND SERVO REVERSING.

L'ENSEMBLE PULSAR PRO-2000 2 VOIES COMPREND MICRO SERVO ET UN MINI VARIATEUR ÉLECTRONIQUE. L'ÉMETTEUR EST POURVU DE TRIMS ET D'INVERSEURS DE SENS DE ROTATION POUR LES SERVO.

RECEIVER/SERVO SET

■RS-V NO.2566  
(FOR BAJA-BUGS)

■RS-M NO.2567  
(FOR MOTORCYCLES)

USE YOUR 2 CHANNEL TRANSMITTER (27 MHZ) TO CONTROL MINIATURE MODELS WITH THIS MICRO RECEIVER/MICRO SERVO SET. INCLUDES MINI ELECTRONIC SPEED CONTROLLER.

UTILISEZ VOTRE RADIO DEUX-VOIES (27 MHZ) EN VUE DE PILOTER DES MODÈLES MINIATURES AVEC CET ENSEMBLE MICRO RÉCEPTEUR/MICRO SERVO, COMPRENANT EN OUTRE UN MINI VARIATEUR ÉLECTRONIQUE.



# 2WD OFF ROAD RACER

■ RAIDER 2WD ■ PEGASUS ■ COSMO  
■ ICARUS ■ ULTIMA





# ELECTRIC POWERED RACING BUGGIES



		Length	Height	Weight	Suspension	Shock Absorber	Motor	Battery	Option Parts
2 W D	RAIDER 2WD	390mm	140mm	1450g	(F)WS/(R)WS	4 Friction Shock Absorbers	LeMans STOCK 05	7.2V-1200mAh	○
	PEGASUS	388mm	133mm	1480g	(F)WS/(R)TS	4 Friction Shock Absorbers	RS-540S	7.2V-1200mAh	△
	COSMO	395mm	125mm	1480g	(F)WS/(R)TS	4 Oil-Filled Shock Absorbers	RS-540S	7.2V-1200mAh	△
	ICARUS	388mm	150mm	1550g	(F)WS/(R)TS	4 Oil-Filled Shock Absorbers	LeMans STOCK 05	7.2V-1200mAh	△
	ULTIMA	360mm	130mm	1500g	(F)WS/(R)WS	4 Oil-Filled Shock Absorbers	RS-540S	7.2V-1200mAh	○

ABBREVIATIONS : POSSIBILITY OF HOP-UP<◎=HIGH, ○=MODERATE, △=LOW> (F)=FRONT, (R)=REAR, WS=DOUBLE WISHBONES SUSPENSION.  
 TS=TRAILING ARM SUSPENSION SS=PILLAR-TYPE INDEPENDENT SUSPENSION.





#### CAR-CRUSHER RACING PERFORMANCE IN MINIATURE!

BIG BRUTE DUPLICATES THE WILD PERFORMANCE OF AMERICAN ENTERTAINMENT "CAR CRUSHER" VEHICLES IN 1/10 SCALE. HUGE 135mm TIRES! JACKED-UP CHASSIS! RUGGED SUSPENSION! POWERFUL LeMANS "STOCK 05" MOTOR FOR CLIMBING, PULLING, AND SPEED. BIG BRUTE CLIMBS OVER OBSTACLES 50mm (2INCHES) HIGH. DOUBLE-WISHBONE SUSPENSION WITH QUALITY FRICTION-TYPE SHOCK ABSORBERS AND LARGE COIL SPRING F+R KEEPS IT UNDER CONTROL. STRONG ABS CHASSIS. SPEEDS: 3FWD/1 REV.

#### REQUIRED FOR OPERATION/ < > : NITRO BRUTE

● RADIO CONTROL SET (2-CHANNEL) ● BATTERY (7.2V-1200mAh NiCd) ● BATTERY CHARGER ● POLYCA COLOR PAINTS ● MICRONLINE STRIPPING TAPE < ● .10 ENGINE >

#### Technical Data/◇: NITRO BRUTE

①Length/460mm(18.1in)<470mm> ②Width/310mm(12.2in) ③Height/250mm(9.8in) ④Wheelbase/283mm(11.5in)<290mm> ⑤Ground Clearance/70mm(2.8in) ⑥Front Track/220mm(8.7in) ⑦Rear Track/215mm(8.5in) ⑧Tires/(F)136φ×80mm (5.4×3.2in);(R)136φ×80mm(5.4×3.2in) ⑨Total Weight/2650g(5lb 13oz) ⑩Gear Ratio/16.1:1<29:1> ⑪Motor/Le Mans Stock 05 (Included) <.09-.11Class Engine> ⑫Battery/7.2V-1200mAh(Not included) ⑬Radio/2-Channel(Not included)

#### Technische Daten

①Longueur ②Largeur ③Hauteur ④Empattement ⑤Garde au sol ⑥Voie Avant ⑦Voie Arrière ⑧Roue ⑨Poids Total ⑩Proportion Dembrayage ⑪Moteur ⑫Nicad

#### L'ÉCRASEUR DE VOITURES, PERFORMANT EN MINIATURE!

VOICI LA REPRODUCTION EN MINIATURE DES 'CAR CRUSHER' AMÉRICAINS À L'ÉCHELLE 1/10. ÉNORMES PNEUS DE 136mm! CHÂSSIS RENFORCÉ, SUSPENSION ULTRA-SOLIDE! LE PUISSANT MOTEUR LeMANS 'STOCK 05' ASSURE AU MODÈLE LA VITESSE, LA TRACTION ET LE POUVOIR D'ESCALADER LES PIRES OBSTACLES (JUSQU'À 5cm DE HAUT!). SUSPENSION À DOUBLES TRIANGLES, AMORTISSEURS À FRICTION ET RESSORTS SUR-DIMENSIONNÉS À L'AVANT COMME À L'ARRIÈRE. CHÂSSIS EN ABS RÉSISTANT. TROIS VITESSES AV ET UNE AR.

#### ACCESSOIRES REQUIS ET DÉCORATION SUGGÉRÉE/ < > : NITRO BRUTE

● ENSEMBLE RADIO À 2 VOIES ● BATTERIE Ni-Cad 7,2V-1200mAh ● CHARGEUR ● PEINTURE POLYCA ● RUBANS DE DÉCORATION MICRONLINE < ● MOTEUR 1,5 À 2,1Cm³ >



## CAR CRUSHER "BIG BRUTE,"

ELECTRIC POWERED OFF-ROAD RECREATIONAL VEHICLE  
NO.3105 • 14800

## CAR CRUSHER "NITRO BRUTE,"

10 ENGINE POWERED OFF-ROAD RECREATIONAL VEHICLE  
NO.3110 • 14800

1:10 SCALE



1. HUGE 136x80mm (5.4x3.2 INCH) HIGH-GRIP RUBBER TIRES.
2. STRONG, PROTECTIVE FRONT BUMPER.
3. DEPENDABLE, EFFECTIVE FRICTION SHOCK ABSORBERS.
4. QUICK-CHANGE BATTERY COMPARTMENT.
5. STRONG, RUGGED ABS CHASSIS.
6. LONG-LIFE SPEED CONTROLLER. 3 SPEEDS FORWARD, 1 REVERS.
7. ENCLOSED, PROTECTIVE RADIO COMPARTMENT.
8. DOUBLE WISHBONE FRONT SUSPENSION. LONG WHEEL TRAVEL. STRONG ABS PARTS.
9. STRONG, LIGHT ABS WHEELS.
10. POWERFUL LeMANS "STOCK 05" MOTOR.
11. SEALED GEARBOX/DIFFERENTIAL FOR PROTECTION FROM DUST, WATER, STRONG ABS GEARS, HARD POLYESTER RESIN GEARS.
12. REAR GUARD PROTECTS MOTOR IN "SHUNTS".
13. DOUBLE-WISHBONE REAR SUSPENSION. LONG WHEEL TRAVEL.

1. ÉNORMES PNEUS 136x80mm À TRÈS BONNE TENUE DE ROUTE.
2. PARE-CHOC DE PROTECTION AV TRÈS RÉSIDANT.
3. AMORTISSEURS À FRICTION EFFICACES ET RÉGLABLE, TRÈS FIABLES.
4. SUPPORT D'ACCUS À REMPLACEMENT INSTANTANÉ.
5. CHÂSSIS SOLIDE EN ABS.
6. VARIATEUR FIABLE À TROIS VITESSES AV ET UNE AR.
7. COMPARTIMENT RADIO ÉTANCHE.
8. SUSPENSION AV EN ABS TRÈS RÉSIDANT, À LONGUE COURSE.
9. ROUES LÉGÈRES, EN ABS TRÈS SOLIDE.
10. MOTEUR PERFORMANT LeMANS "STOCK 05".
11. CARTER ENGRENAGES/DIFFÉRENTIEL ÉTANCHE, ÉVITANT TOUTE INFILTRATION DE POUSSIÈRE ET D'HUMIDITÉ: PIGNONS EN ABS ET EN RÉSINE POLYACÉTATE DUR.
12. PROTECTION ARRIÈRE DU MOTEUR CONTRE LES COLLISIONS.
13. SUSPENSION AR PAR DOUBLES TRIANGLES EN ABS TRÈS RÉSIDANT À LONGUE COURSE.

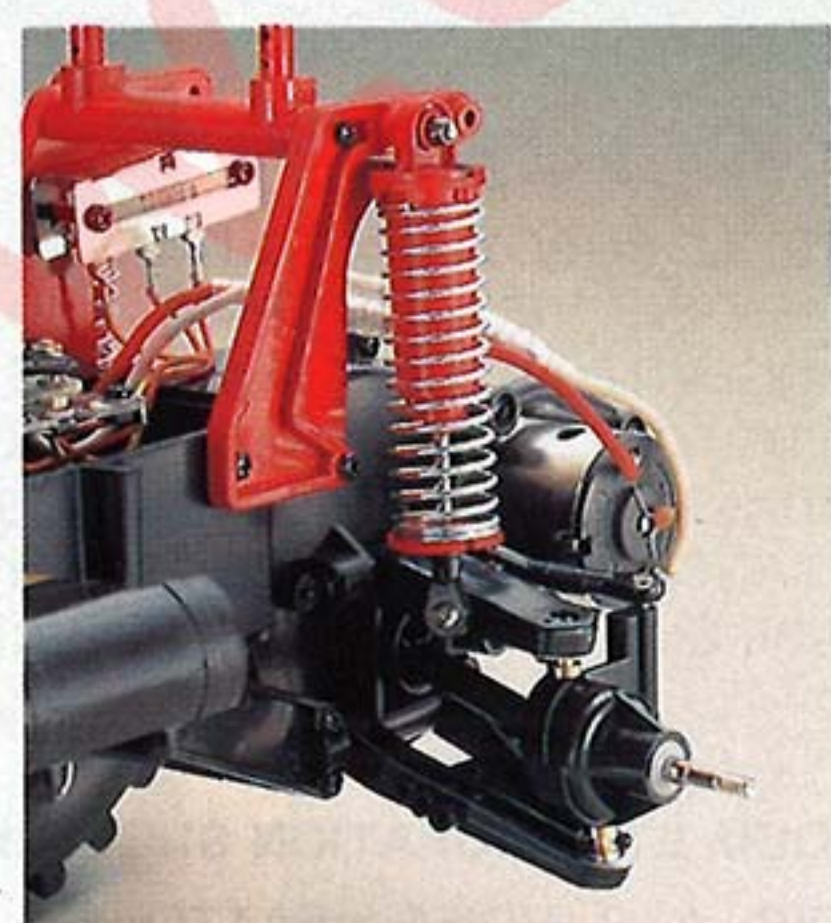
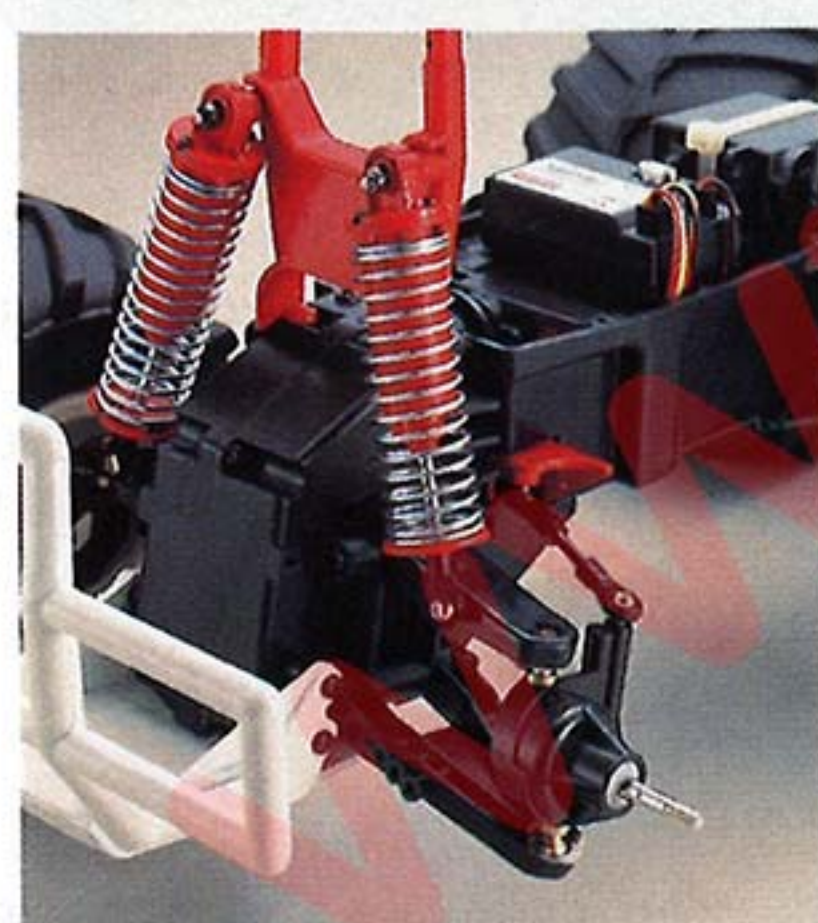
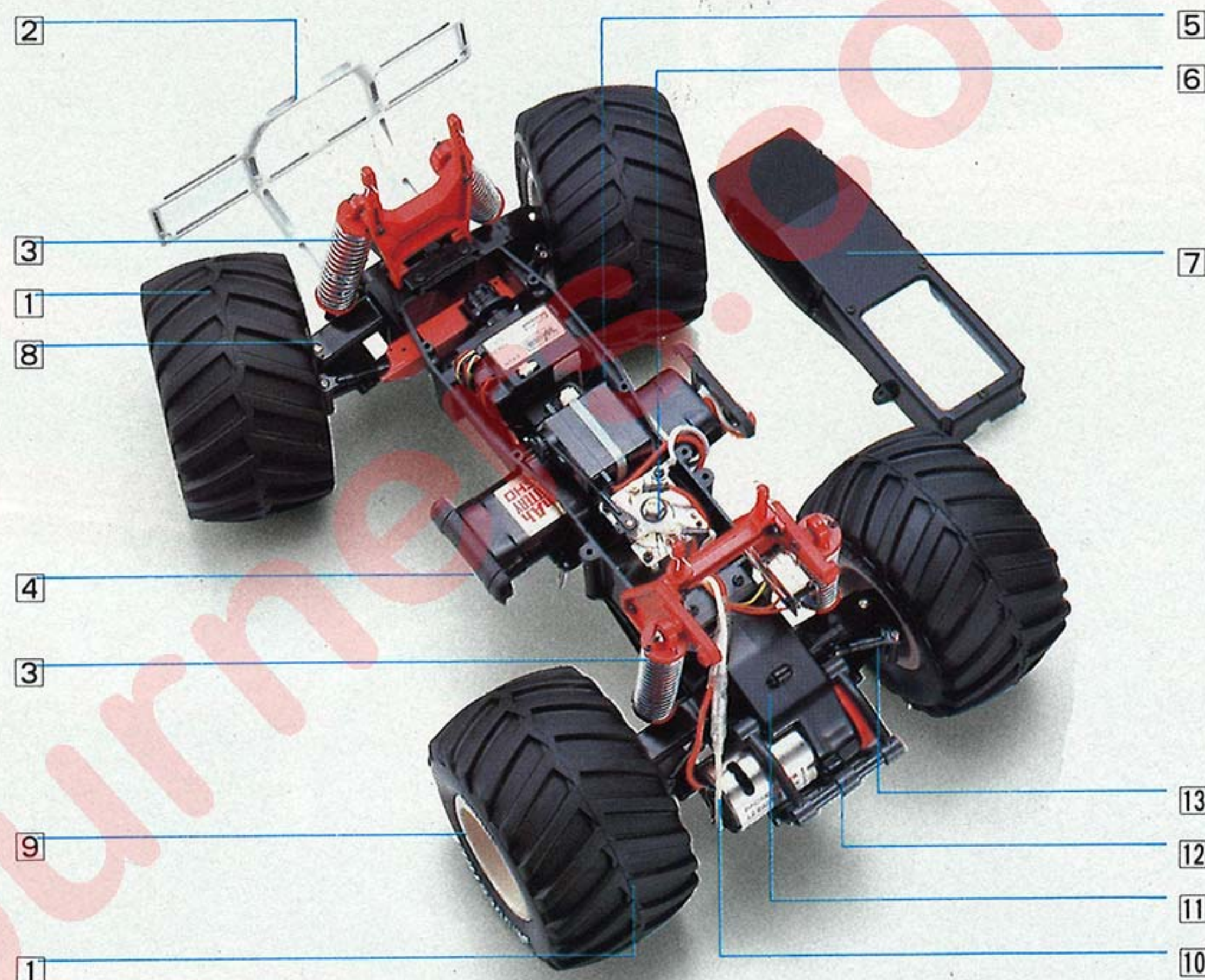

RUGGED, LONG-TRAVEL DOUBLE-WISHBONE SUSPENSION FRONT AND REAR. DESIGNED STRONG TO ABSORB ROUGH TREATMENT. STRONG ABS PART. STEEL PIVOTS. FRICTION SHOCKS.

SUSPENSION AV ET AR À DOUBLE BRAS LONGUE COURSE DE CONCEPTION EXTRÊMEMENT RÉSIDANTE EN VUE D'ABSORBER LES PIRES SOLLECITATIONS.



BIG BRUTE'S HUGE TIRES LET IT CLIMB OVER HIGH OBSTACLES, LIKE THE REAL "CAR CRUSHERS"! AGILE AND POWERFUL. LES ÉNORMES PNEUS DU BIG BRUTE PERMETTENT DE FRANCHIR DES OBSTACLES IMPORTANTS, TOUT COMME LES VRAIS 'CAR CRUSHERS'!

### ■ NITRO BRUTE

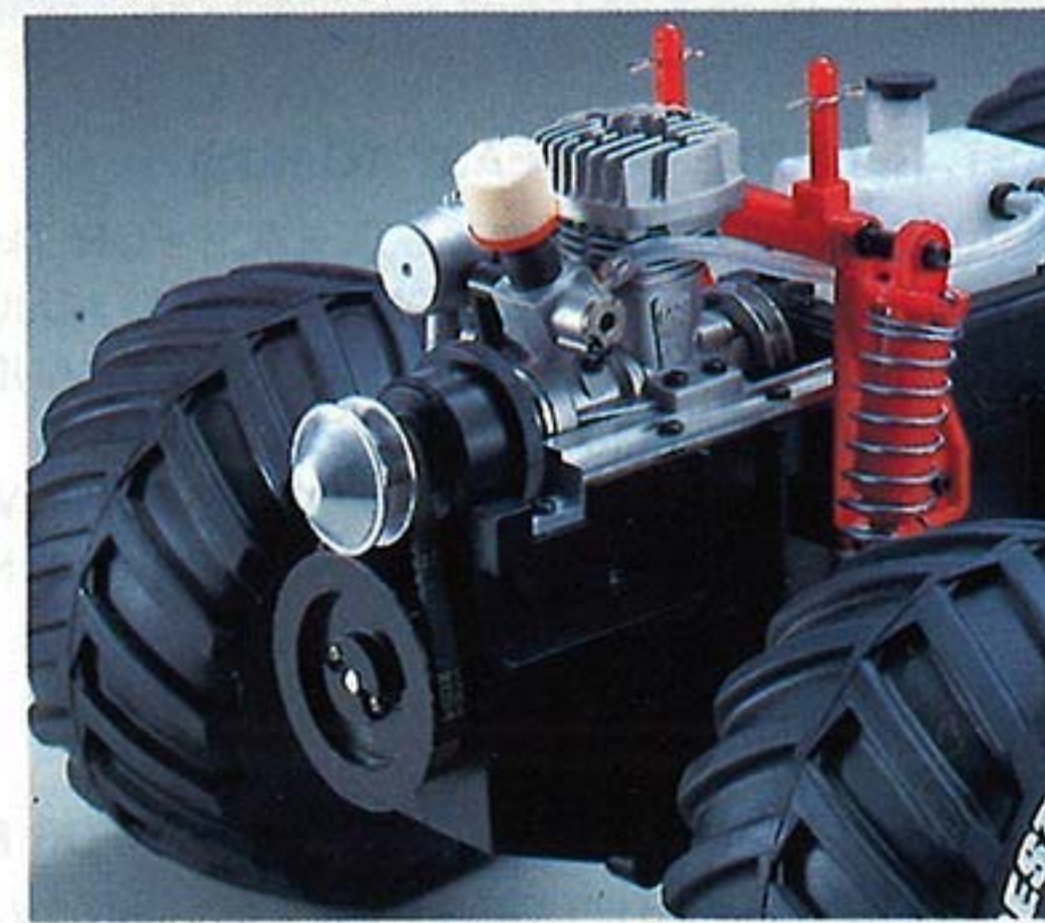

NITRO BRUTE HAS THE EXTRA POWER AND SPEED OF A .10-CLASS ENGINE, WITH REAL ENGINE SOUNDS. SPECIAL MUFFLER INCLUDED IN KIT. (ENGINE NOT INCLUDED.)



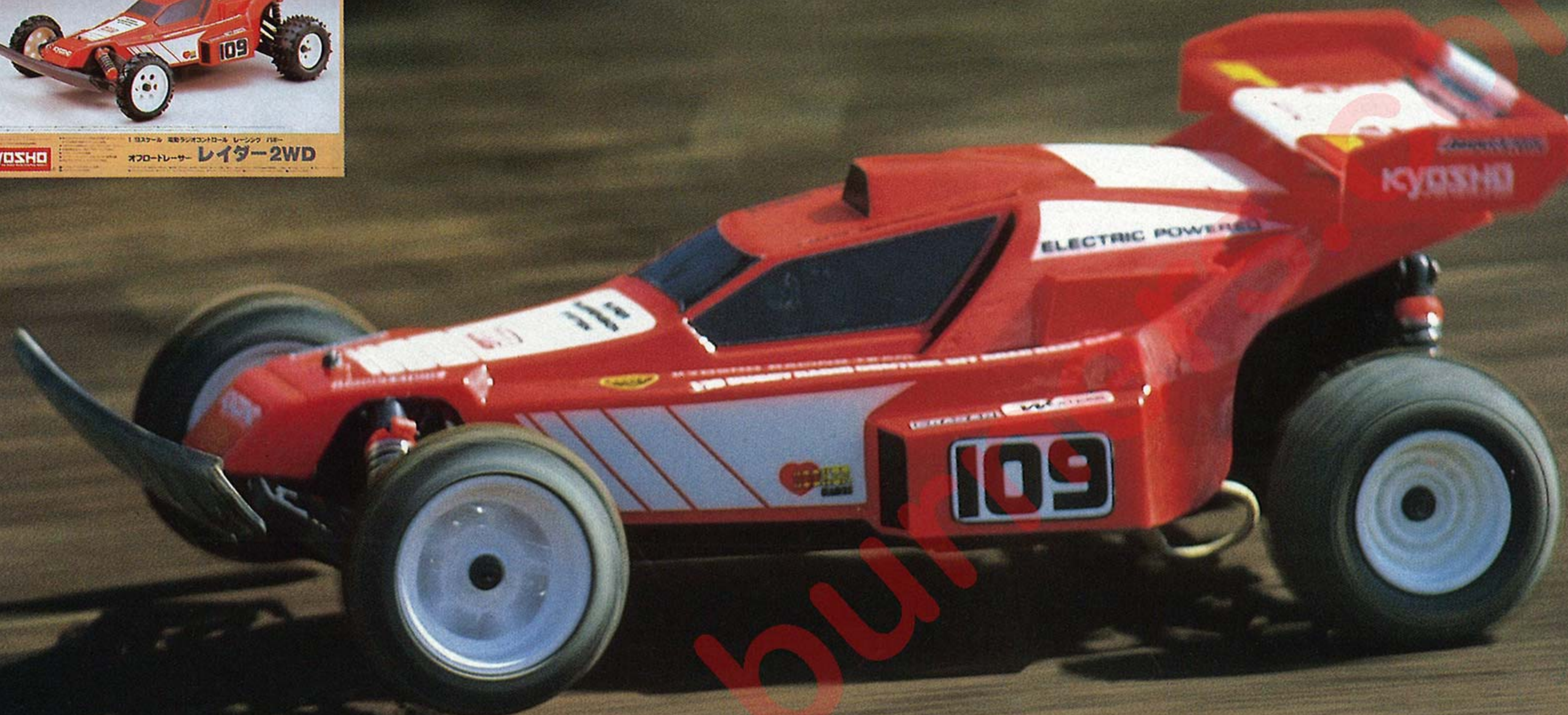

#### FAST, RELIABLE, AND EASY TO RUN!

"RAIDER 2WD", THE IDEAL CHOICE FOR THE NEW DRIVER. FAST PERFORMANCE WITH A MINIMUM OF CONSTRUCTION TIME AND ADJUSTMENT. DURABLE MATERIALS. FOUR-WHEEL INDEPENDENT SUSPENSION FOR GOOD HANDLING ON ANY SURFACE. LIGHT FRICTION-TYPE SHOCK ABSORBERS. POWERFUL LeMANS "STOCK 05" MOTOR AND SPEED CONTROLLER (3FWD/1REV) INCLUDED. RELIABLE REAR-WHEEL DRIVE WITH GEAR-TYPE DIFFERENTIAL COMBINES WITH HIGH-GRIP TIRES TO PUT MAXIMUM POWER ON THE TRACK.

#### REQUIRED FOR RUNNING/SUGGESTED FOR BEST APPEARANCE

● 2-CHANNEL RADIO CONTROL SET ● 7.2V-1200mAh NiCd BATTERY PACK ● CHARGER ● POLYCA COLOR PAINT

#### Technical Data

① Length/390mm(15.4in) ② Width/250mm(9.8in) ③ Height/140mm(5.5in) ④ Wheelbase/260mm(10.2in) ⑤ Ground Clearance/29mm(1.1in) ⑥ Front Track/200mm(7.9in) ⑦ Rear Track/210mm(8.3in) ⑧ Tires/(F)77φ×23mm(3.0×0.9in);(R)82φ×40mm(3.2×1.6in) ⑨ Total Weight/1450g(51.1oz) ⑩ Gear Ratio/10.8:1 ⑪ Motor/Le Mans Stock 05(Included) ⑫ Battery/7.2V-1200mAh(Not included) ⑬ Radio/2-Channel(Not included)

#### Technische Daten

① Longueur ② Largeur ③ Hauteur ④ Empattement ⑤ Garde au sol ⑥ Voie Avant ⑦ Voie Arrière ⑧ Roue ⑨ Poids Total ⑩ Proportion Dembrayage ⑪ Moteur ⑫ Nicad

#### LA PERFORMANCE DÈS LE DÉBUT!

LE RAIDER 2WD EST LE BUGGY DE DÉBUT IDÉAL. FACILE À ASSEMBLER ET À METTRE AU POINT, ET NÉANMOINS TRÈS PERFORMANT. EXTRÊME FIABILITÉ D'UNE CONCEPTION TRÈS ÉTUDIÉE, LONGÉVITÉ ABSOLUE SUITE AU CHOIX MÉTICULEUX DES MATÉRIAUX. LA VOITURE POSSÈDE TOUTES LES CARACTÉRISTIQUES DES BUGGIES DE PERFORMANCE: 4 ROUES INDÉPENDANTES, UN DIFFÉRENTIEL ASSURANT LA TRACTION DES ROUES EN TOUTES CIRCONSTANCES, MOTEUR PERFORMANT ET VARIATEUR À 3 VITESSES AV ET 1 AR (INCLUS), PARE-CHOC EFFICACE ET BONNE TENUE DE ROUTE.

#### ACCESSOIRES REQUIS ET DÉCORATION SUGGÉRÉE

• ENSEMBLE RADIO À 2 VOIES • BATTERIE Ni-Cad 7,2V-1200mAh • CHARGEUR • PEINTURES POLYCA



# OFF-ROAD RACER "RAIDER 2WD,"

## ELECTRIC POWERED RACING BUGGY

1:10 SCALE  
NO.3184 • 8800



- 1 LARGE BUMPER TO PROTECT BUGGY FROM COLLISION.
- 2 RELIABLE LIGHT, FRICTION SHOCKS FRONT AND REAR.
- 3 BLOCK PATTERN FRONT TIRE FOR DIRECTIONAL CONTROL.
- 4 STRONG, LIGHT WHEEL.
- 5 INDEPENDENT SUSPENSION FRONT/REAR FOR TOP HANDLING.
- 6 FLAT, ONE-PIECE, HIGH-STRENGTH CHASSIS.
- 7 SPEED CONTROLLER (3FWD/1REV; INCLUDED).
- 8 MIDSHIPS-MOUNTED "STOCK 05" MOTOR (INCLUDED) FOR BEST BALANCE.
- 9 GEAR TYPE DIFFERENTIAL (INSIDE PROTECTIVE HOUSING).
- 10 SPIKE PATTERN REAR TIRE FOR TOP TRACTION.

1. PARE-CHOCs EFFICACE
2. AMORTISSEURS À FRICTION FIABLES ET LÉGERS AV ET AR.
3. PNEUS AV À PROFIL ASSURANT UNE TRAJECTOIRE STABLE.
4. JANTES SOLIDES MAIS LÉGÈRES.
5. SUSPENSION INDÉPENDANTE DES 4 ROUES.
6. CHÂSSIS PLAT ET INTÉGRAL DE HAUTE RIGIDITÉ.
7. VARIATEUR À 3 VITESSES AV ET 1 AR (INCLUS).
8. MOTEUR 'STOCK 05' (INCLUS) INSTALLÉ AU CENTRE DU MODÈLE POUR UNE MEILLEURE RÉPARTITION DES MASSES.
9. DIFFÉRENTIEL À ENGRENAGES ÉTANCHE.
10. PNEUS AR À POINTES POUR UNE TRACTION MAXIMALE.

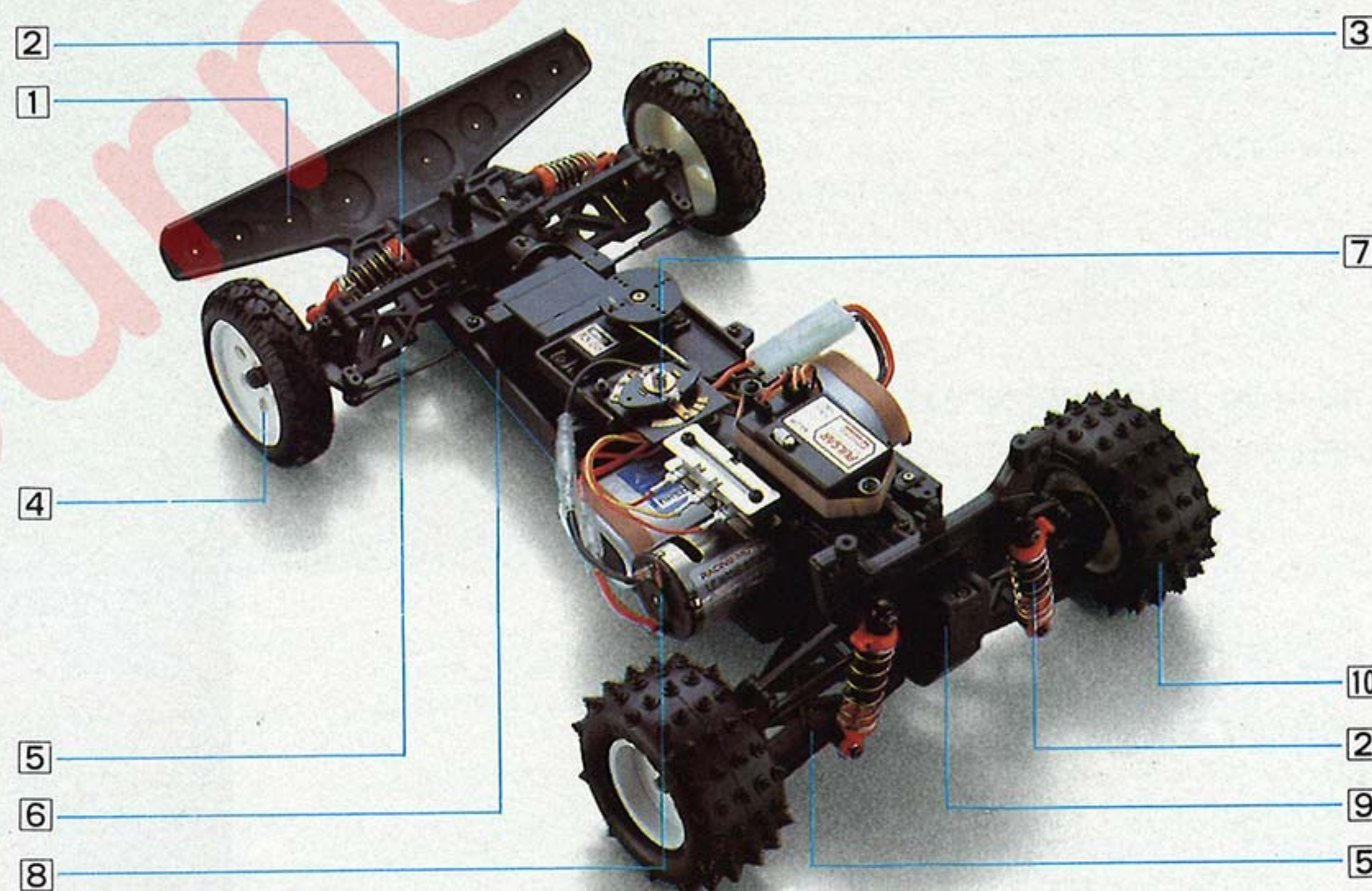

FRONT SUSPENSION. WISHBONE/PARALLEL ARM TYPE. LONG-TRAVEL FOR GOOD ROAD-HOLDING.

SUSPENSION AV À TRIANGLES PARALLÈLES LONGUE COURSE POUR UNE TENUE DE ROUTE OPTIMALE.

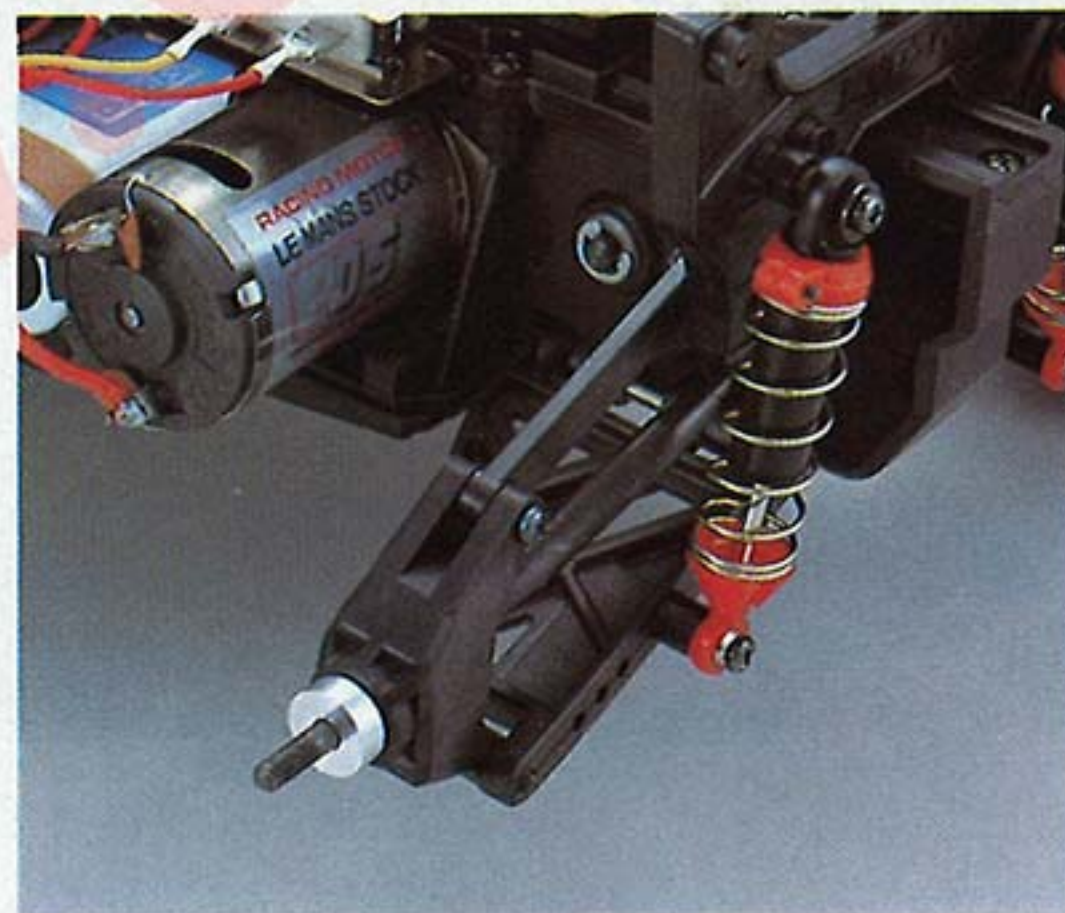

REAR SUSPENSION (SAME DESIGN). RELIABLE FRICTION SHOCK. ADJUSTABLE SHOCK MOUNTS.

SUSPENSION AR DE LA MÊME CONCEPTION, FIABLE À AMORTISSEURS À FRICTION. SUPPORTS D'AMORTISSEURS RÉGLABLES.

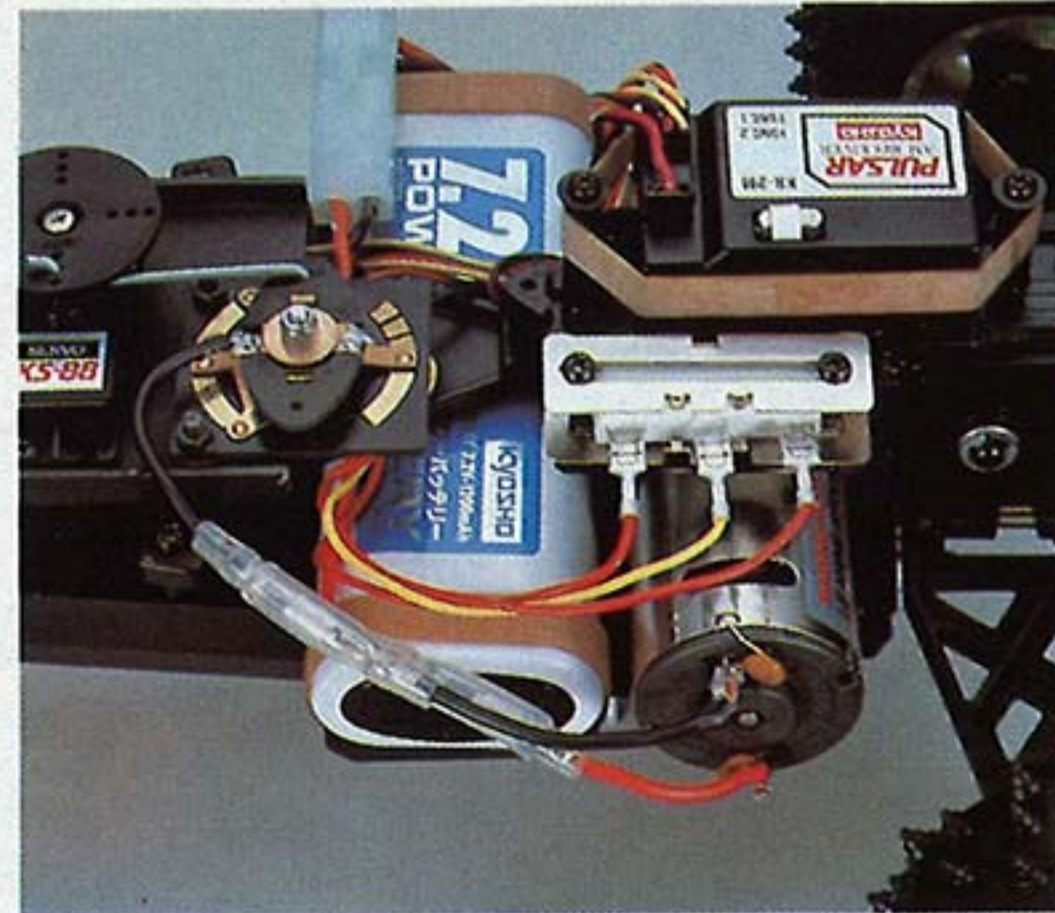

MIDSHIPS MOTOR POSITION AND LOW BATTERY MOUNT FOR BEST BALANCE. SPEED CONTROLLER.

INSTALLATION CENTRALE MOTEUR ET BATTERIE SURBAISSÉE EN VUE D'UNE RÉPARTITION IDÉALE DES MASSES. VARIATEUR DE VITESSE.







# OFF-ROAD RACER "PEGASUS,"

## ELECTRIC POWERED RACING BUGGY

1:10 SCALE  
NO.3082 • 9800



### THE IDEAL ENTRY-LEVEL ELECTRIC BUGGY.

- ① LIGHTWEIGHT ABS THREE-PIECE RACING WHEELS.
- ② PNEUMATIC (NOT SOLID) RUBBER TIRES.
- ③ EFFECTIVE FRICTION-TYPE SHOCK ABSORBERS (OIL-FILLED TYPE OPTIONAL).
- ④ LARGE BUMPER FOR CRASH PROTECTION.
- ⑤ "UNIVERSAL" MOUNT FOR ANY SERVO.
- ⑥ DOUBLE-WISHBONE FRONT SUSPENSION WITH INFINITE-FLEX MONOHINGE PIVOTS.
- ⑦ SPACIOUS CHASSIS GIVES DUST PROTECTION, LOW-CG BATTERY MOUNTING POSITION.
- ⑧ WIDE HIGH-TRACTION PNEUMATIC TIRE.
- ⑨ LIGHTWEIGHT, STRONG ABS THREE PIECE WHEEL.
- ⑩ HIGH-CURRENT STEPLESS SPEED CONTROLLER (WITH REVERSE).
- ⑪ POWERFUL MABUCHI 540S MOTOR INCLUDED IN KIT.
- ⑫ SEALED GEARBOX FEATURES PRECISION MOLDED NYLON GEARS FOR SMOOTH POWER DELIVERY.

### LE BUGGY ÉLECTRIQUE IDÉAL DE DÉBUT

1. JANTES DE COMPÉTITION ABS EN TROIS PARTIES.
2. PNEUS EN CAOUTCHOUC.
3. AMORTISSEURS À FRICTION EFFICACES (HYDRAULIQUES EN OPTION).
4. PARE-CHOC SURDIMENSIONNÉ.
5. PORTE-SERVO UNIVERSSEL.
6. SUSPENSION AV À DOUBLE TRIANGLE.
7. CHÂSSIS SPACIEUX ASSURANT UNE BONNE PROTECTION CONTRE LA POUSSIÈRE ET UNE INSTALLATION SURBAISSÉE DE LA BATTERIE.
8. PNEUS LARGES POUR UNE MEILLEURE TRACTION.
9. JANTES LÉGÈRES ABS EN TROIS PARTIES.
10. VARIATEUR PROGRESSIF À HAUT DÉBIT (AVEC MARCHÉ AR).
11. MOTEUR PUISSANT MABUCHI 540S (INCLUS).
12. ENGRENAGES DE PRÉCISION EN NYLON RENFERMÉS DANS UN CARTER ÉTANCHE.

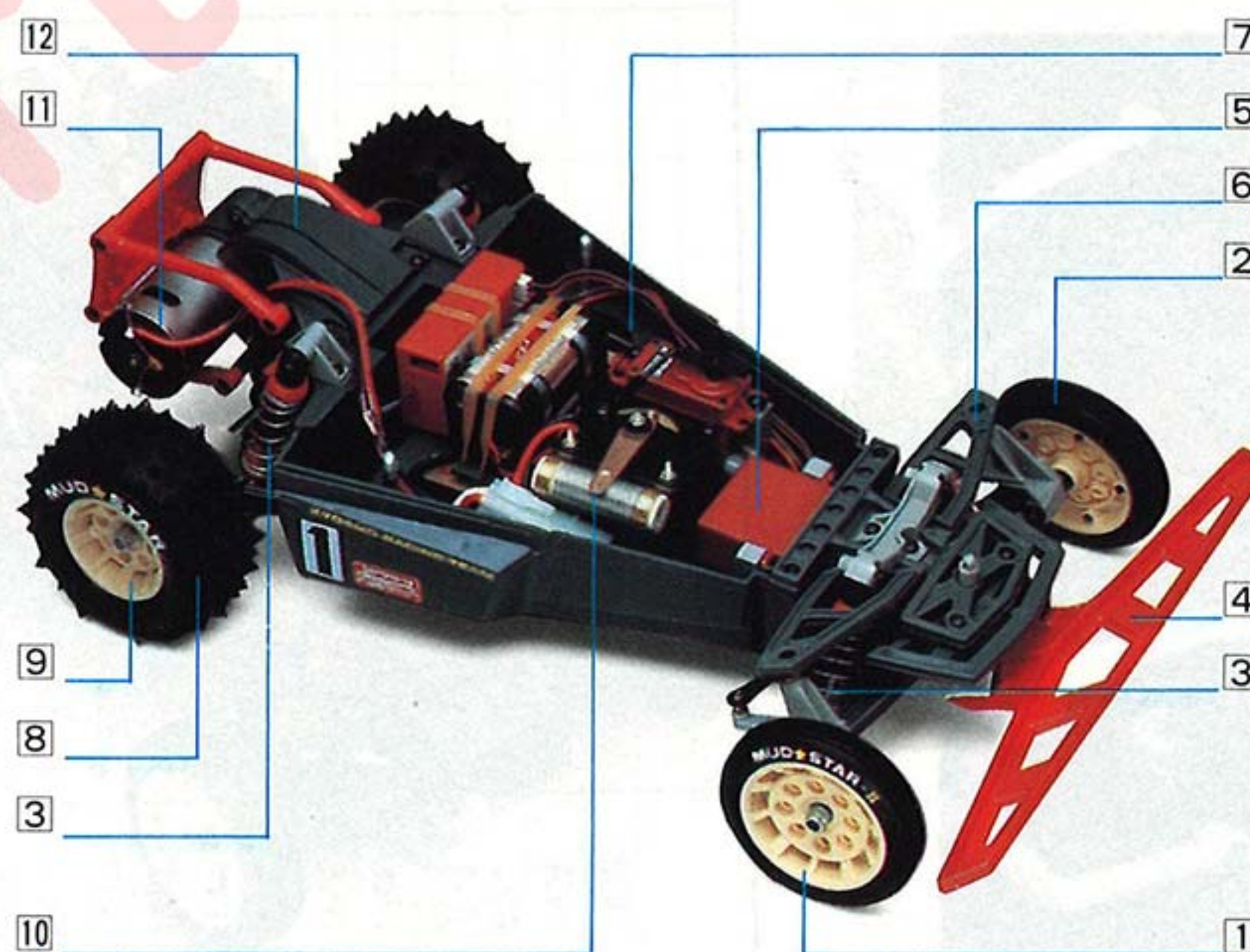
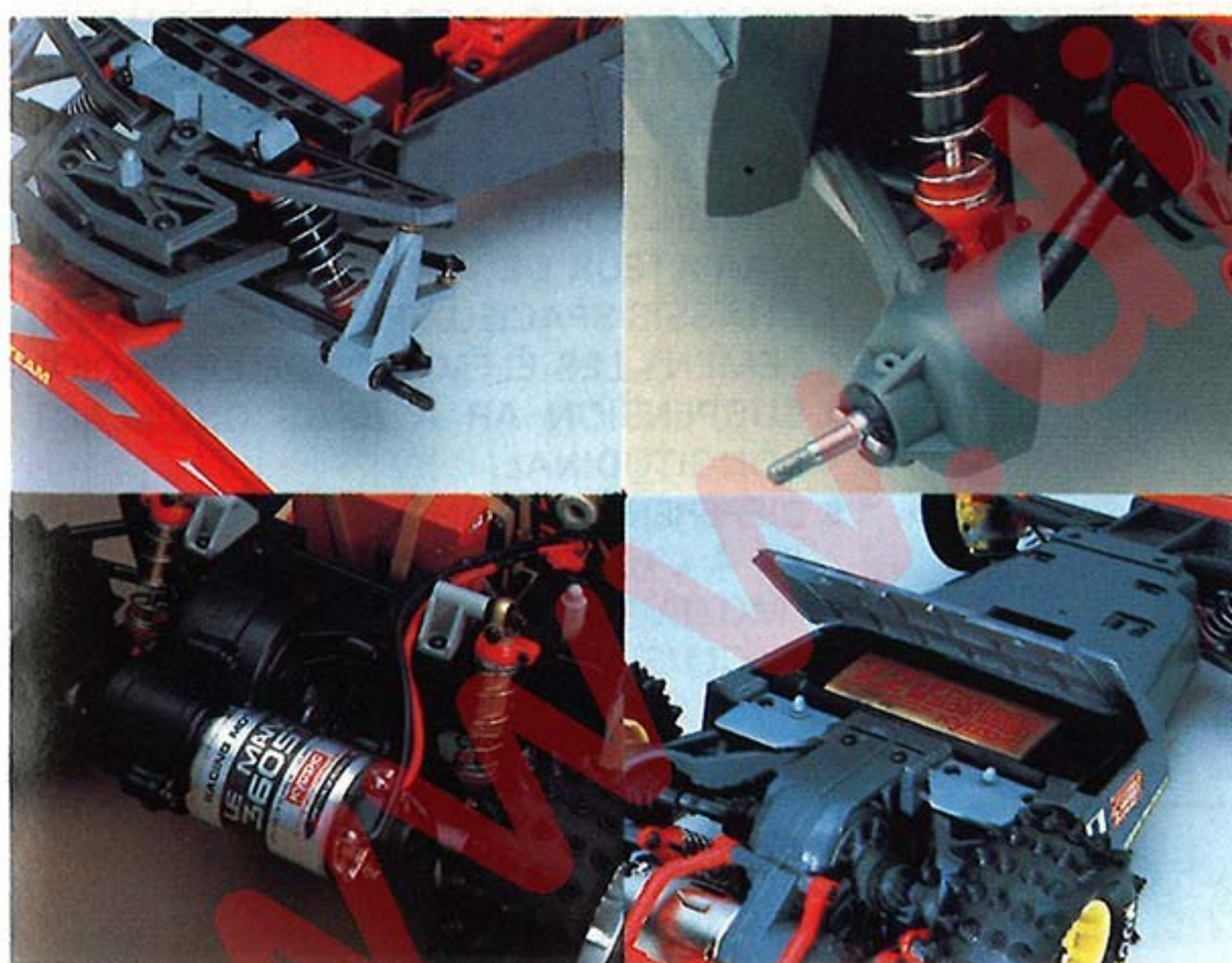

### REQUIRED FOR OPERATION/SUGGESTED FOR BEST APPEARANCE

- 2-CHANNEL RADIO CONTROL SET ● 7.2V-1200mAh NiCd BATTERY PACK ● CHARGER ● POLYCA COLOR PAINT

#### Technical Data

- ① Length/388mm(15.3in) ② Width/232mm(9.1in) ③ Height/133mm(5.2in) ④ Wheelbase/255mm(10.2in) ⑤ Ground Clearance/25mm(1.0in) ⑥ Front Track/188mm(7.4in) ⑦ Rear Track/190mm(7.5in) ⑧ Tires/(F)70φ×15mm(2.75×0.6in);(R)85φ×40mm(3.35×1.6in) ⑨ Total Weight/1450g(51oz) ⑩ Gear Ratio/8.35:1 ⑪ Motor/RS-540S(Included) ⑫ Battery/7.2V-1200mAh(Not included) ⑬ Radio/2-Channel(Not included)

#### Technische Daten

- ① Longueur ② Largeur ③ Hauteur ④ Empattement ⑤ Garde au sol ⑥ Voie Avant ⑦ Voie Arrière ⑧ Roue ⑨ Poids Total ⑩ Propotion Dembrayage ⑪ Moteur ⑫ Nicad

### ACCESSOIRES REQUIS ET DÉCORATION SUGGÉRÉE

- ENSEMBLE RADIO À 2 VOIES ● BATTERIE Ni-Cad 7,2V-1200mAh ● CHARGEUR ● PEINTURES POLYCA ●



# OFF-ROAD RACER "COSMO," ELECTRIC POWERED RACING BUGGY

1:10 SCALE  
NO.3084 • 11500



FOR THE MOST FUN WITH THE LEAST INVESTMENT, COSMO'S THE BUGGY!

- ① POWERFUL MABUCHI RS-540S MOTOR (INCLUDED IN KIT).
- ② ENCLOSED DIFFERENTIAL PROTECTS GEARBOX/DIFFERENTIAL FROM DUST.
- ③ HIGH-QUALITY, OIL-FILLED SHOCK ABSORBER.
- ④ GUARD PLATE PREVENTS BURNS FROM HOT SPEED-CONTROLLER RESISTOR.
- ⑤ LOW-PROFILE FRONT TIRE.
- ⑥ REAR BUMPER PROTECTS MOTOR FROM COLLISION DAMAGE.
- ⑦ TRAILING-ARM REAR SUSPENSION.
- ⑧ LOW-PROFILE BLOCK-PATTERN KNOBBY.
- ⑨ STRONG, LIGHT NYLON WHEEL.
- ⑩ SPACIOUS "TUB" TYPE BODY PROTECTS RADIO GEAR.
- ⑪ OIL-FILLED FRONT ABSORBER.
- ⑫ WISHBONE/PARALLEL ARM FRONT SUSPENSION, EXTRA-LONG FOR TOP HANDLING.

POUR UN MAXIMUM DE PLAISIR MOYENNANT L'INVESTISSEMENT MINIMAL, LE COSMO EST VOTRE BUGGY!

1. PARE-CHOC EFFICACE ET RÉSISTANT.
2. PNEUS RAINURÉS POUR UNE MEILLEURE STABILITÉ DE TRAJECTOIRE.
3. SUSPENSION À BRAS PARALLÈLES À GRAND DÉBATTEMENT.
4. AMORTISSEUR HYDRAULIQUE DE HAUTE QUALITÉ.
5. PARE-CHOC AR EN VUE DE PROTÉGER LE MOTEUR DES COLLISIONS.
6. PROTECTION DES PARTIES CHAUDES DU VARIATEUR DE VITESSES.
7. CHÂSSIS SPACIEUX PROTÉGÉANT IDÉALEMENT LES ÉLÉMENTS DE LA RADIO.
8. SUSPENSION AR À BRAS OSCILLANT LONGITUDINAL.
9. DIFFÉRENTIEL ÉTANCHE À LA POUSSIÈRE ET À L'HUMIDITÉ.
10. MOTEUR PUISSANT MABUCHI RS-540S (INCLUS).
11. PNEUS PROFILÉS EN VUE D'UNE TRACTION MAXIMALE.
12. JANTES EN NYLON LÉGÈRES MAIS SOLIDES.



## REQUIRED FOR OPERATION/SUGGESTED FOR BEST APPEARANCE

● 2-CHANNEL RADIO CONTROL SET ● 7.2V-1200mAh NiCd BATTERY PACK ● CHARGER ● POLYCA COLOR PAINT

### Technical Data

① Length/395mm(15.6in) ② Width/220mm(8.7in) ③ Height/125mm(4.9in) ④ Wheelbase/255mm(10.0in) ⑤ Ground Clearance/25mm(1.0in) ⑥ Front Track/185mm(7.3in) ⑦ Rear Track/190mm(7.5in) ⑧ Tires/(F)75φ × 20mm(3.0 × 0.8in);(R)85φ × 35mm(3.5 × 1.5in) ⑨ Total Weight/1480g(52oz) ⑩ Gear Ratio/8.35:1 ⑪ Motor/RS-540S(Included) ⑫ Battery/7.2V-1200mAh(Not included) ⑬ Radio/2-Channel(Not included)

### Technische Daten

① Longueur ② Largeur ③ Hauteur ④ Empattement ⑤ Garde au sol ⑥ Voie Avant ⑦ Voie Arrière ⑧ Roue ⑨ Poids Total ⑩ Propotion Dembrayage ⑪ Moteur ⑫ Nicad

## ACCESSOIRES REQUIS ET DÉCORATION SUGGÉRÉE

● ENSEMBLE RADIO 2 VOIES ● BATTERIE NiCad 7,2V-1200mAh ● CHARGEUR ● PEINTURES POLYCA ●



# OFF-ROAD RACER "ICARUS," ELECTRIC POWERED RACING BUGGY

1:10 SCALE  
NO.3083 • 11800



## HIGH-PERFORMANCE OFF-ROAD RACING WITH MINIMUM COST.

- ① QUALITY RUBBER SEMI-PNEUMATIC KNOBBY TIRE.
- ② SUPER-POWER LeMANS 360ST MOTOR.
- ③ SEALED GEARBOX WITH PRECISION-MOLDED NYLON GEARS.
- ④ LIGHTWEIGHT ABS WHEELS WITH SPORTY ALUMINIZED FINISH.
- ⑤ OIL-FILLED SHOCK-ABSORBER/SPRING UNIT.
- ⑥ SPACIOUS CHASSIS FOR DUST/WATER PROTECTION, EASY MOUNTING OF SERVOS.
- ⑦ HIGH-CURRENT STEPLESS SPEED CONTROLLER (WITH REVERSE).
- ⑧ RUBBER SEMI-PNEUMATIC TIRE.
- ⑨ DOUBLE-WISHBONE FRONT SUSPENSION WITH INFINITE-FLEX MONO HINGE PIVOTS.
- ⑩ OIL-FILLED SHOCK-ABSORBER/SPRING UNIT.
- ⑪ LIGHTWEIGHT ALUMINIZED ABS WHEEL.
- ⑫ STRONG FRONT BUMPER.

## LA PERFORMANCE TOUS-TERRAINS MAXIMALE POUR UN INVESTISSEMENT MINIMUM.

1. PNEUS EN CAOUTCHOUC À POINTES.
2. MOTEUR SUPER PUISSANT LeMANS 360ST.
3. CARTER ÉTANCHE À ENGRENAGES DE PRÉCISION EN NYLON.
4. JANTES LÉGÈRES EN ABS DE COULEUR ALUMINIUM.
5. SUSPENSION PAR RESSORT HÉLICOÏDAL ET AMORTISSEUR HYDRAULIQUE.
6. CHÂSSIS SPACIEUX PROTÉGÉANT LA RADIO DE LA POUSSIÈRE ET DE L'HUMIDITÉ. INSTALLATION SIMPLE DES SERVOS.
7. VARIATEUR PROGRESSIF À HAUT DÉBIT DE COURANT, COMPRENANT LA MARCHÉ AR.
8. PNEUS SEMI-PNEUMATIQUES EN CAOUTCHOUC.
9. SUSPENSION AV À DOUBLES BRAS.
10. ENSEMBLE RESSORT HÉLICOÏDAL/AMORTISSEUR HYDRAULIQUE.
11. JANTES LÉGÈRES EN ABS DE COULEUR ALUMINIUM.
12. PARE-CHOC AV HAUTE RÉSTANCE.

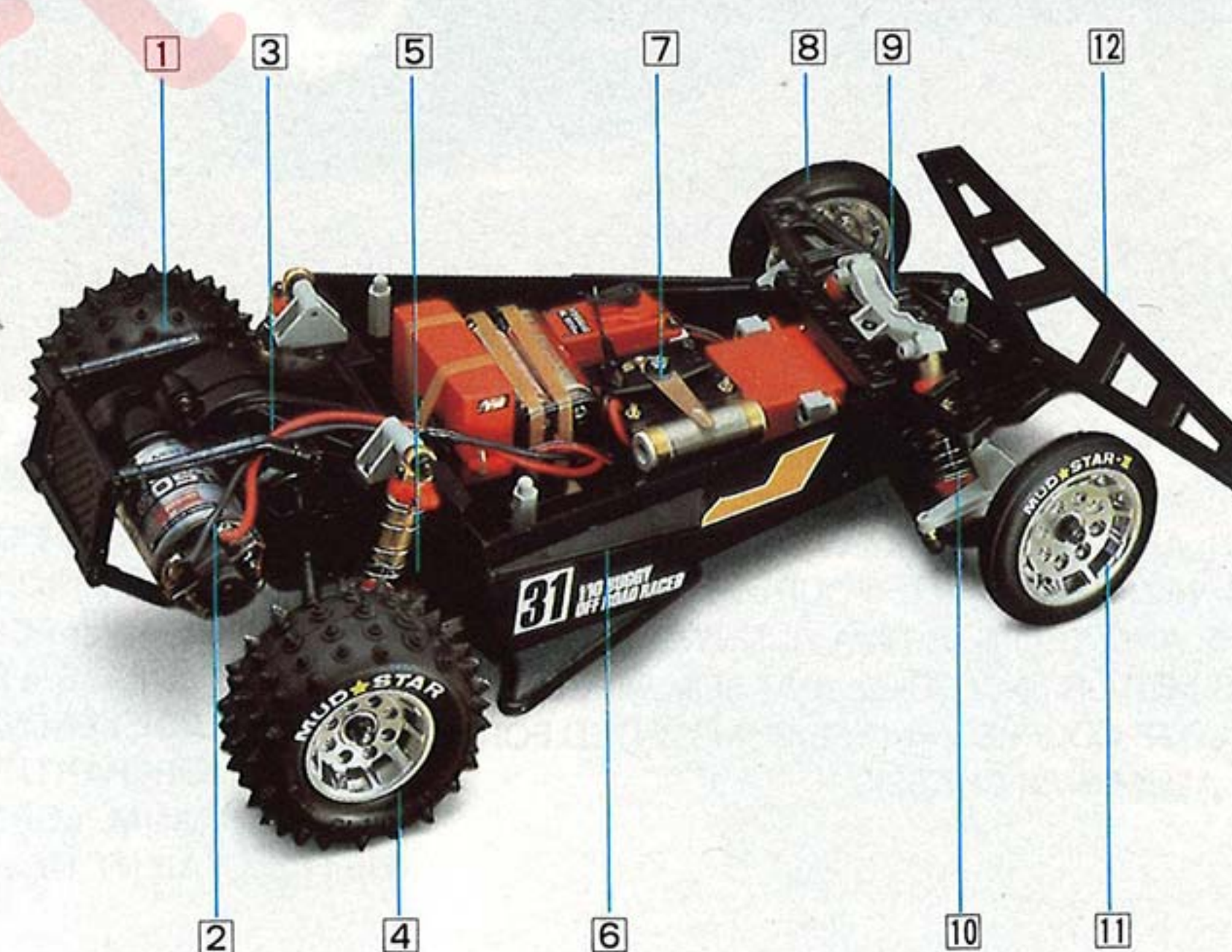

### REQUIRED FOR RUNNING/SUGGESTED FOR BEST APPEARANCE

- 2-CHANNEL RADIO CONTROL SET ● 7.2V-1200mAh NiCd BATTERY ● POLYCA COLOR PAINT ● MICRONLINE STRIPING TAPE

### Technical Data

- ① Length/388mm(15.2in) ② Width/232mm(9.1in) ③ Height/150mm(5.9in) ④ Wheelbase/255mm(10.0in) ⑤ Ground Clearance/25mm(0.9in) ⑥ Front Track/188mm(7.4in) ⑦ Rear Track/190mm(7.5in) ⑧ Tires/(F)70φ×15mm(2.8×0.5in); (R)85φ×40mm(3.3×1.6in) ⑨ Total Weight/1550g(54oz) ⑩ Gear Ratio/8.35 : 1 ⑪ Motor/Le Mans 360ST(Included) ⑫ Battery/7.2V-1200mAh(Not included) ⑬ Radio/2-Channel(Not included)

### Technische Daten

- ① Longueur ② Largeur ③ Hauteur ④ Empattement ⑤ Garde au sol ⑥ Voie Avant ⑦ Voie Arrière ⑧ Roue ⑨ Poids Total ⑩ Proportion Dembrayage ⑪ Moteur ⑫ Nicad

### ACCESSOIRES REQUIS ET DÉCORATION SUGGÉRÉE

- ENSEMBLE RADIO 2 VOIES • BATTERIE NiCd 7,2V-1200mAh • CHARGEUR • PEINTURES • POLYCA • FILETS ADHÉSIFS MICRONLINE •







# OFF-ROAD RACER "ULTIMA,"

## ELECTRIC POWERED RACING BUGGY

1:10 SCALE  
NO.3115 • 14800



- 1 NEW-DESIGN LOW-PROFILE FRONT TIRE.
- 2 OVERSIZE OIL-FILLED SHOCK ABSORBER.
- 3 EXTRA-LONG PARALLEL WISHBONE/ARM FRONT SUSPENSION FOR UNEXCELLED SHOCK ABSORPTION.
- 4 STRONG NEW ALUMINUM PLATE/TRUSS CHANNEL-TYPE CHASSIS.
- 5 STYLISH, STRONG NYLON REAR WHEEL FOR LOW-PROFILE TIRE.
- 6 HEATSINK TO EXTEND EFFECTIVENESS OF SPEED-CONTROLLER RESISTOR.
- 7 POWERFUL, RELIABLE MABUCHI RS-540S MOTOR (INCLUDED IN KIT).
- 8 EXTRA-LONG PARALLEL WISHBONE/ARM REAR SUSPENSION.
- 9 LOW-PROFILE, HIGH-TRACTION PIN-SPIKE REAR TIRE.

1. PNEUS AV À PROFIL BAS D'UN NOUVEAU DESSIN.
2. AMORTISSEURS HYDRAULIQUES SURDIMENSIONNÉS.
3. SUSPENSION AV À BRAS PARALLÈLES SURDIMENSIONNÉS POUR UNE ABSORPTION MAXIMALE DES CHOCS.
4. CHÂSSIS EN TÔLE D'ALUMINIUM RECOURBÉE ULTRA RIGIDE.
5. JANTES AR EN NYLON RENFORCÉ POUR PNEUS À PROFIL BAS.
6. RADIATEUR DE RÉSTANCE DU VARIATEUR DE VITESSES.
7. MOTEUR PUISSANT ET FIABLE MABUCHI RS-540S (INCLUS).
8. SUSPENSION AR À BRAS SURDIMENSIONNÉS.
9. PNEUS AR À PROFIL BAS ET POINTES.

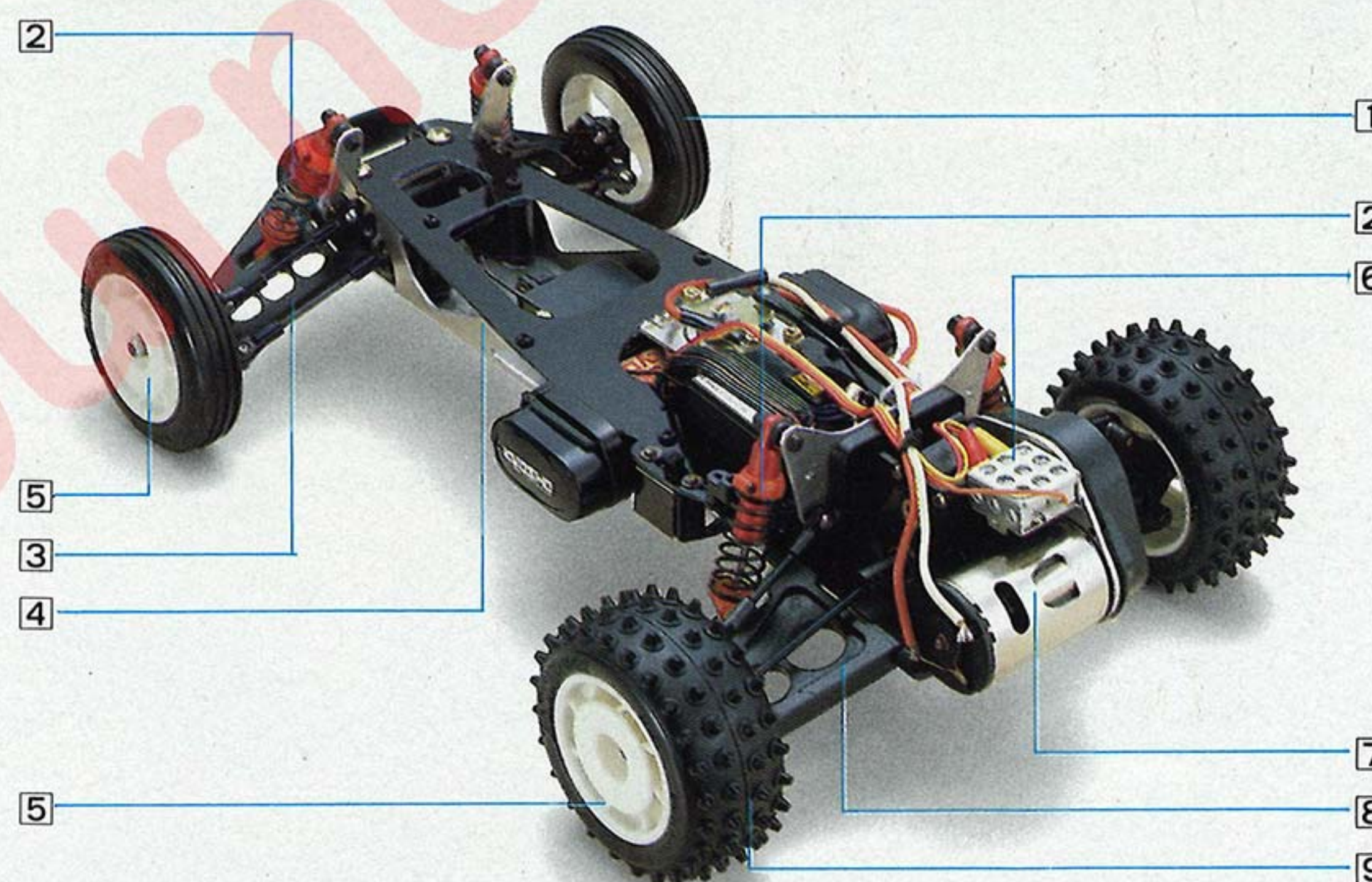

PARALLEL WISHBONE/ARM FRONT/REAR SUSPENSION. OIL-FILLED SHOCKS. SUSPENSION AV ET AR PAR TRIANGLES PARALLÈLES. AMORTISSEURS HYDRAULIQUES.



STRONG NYLON SUSPENSION PARTS. FOUR-WHEEL INDEPENDENT SUSPENSION. QUATRE ROUES INDÉPENDANTES. SUSPENSION EN NYLON RENFORCÉ.

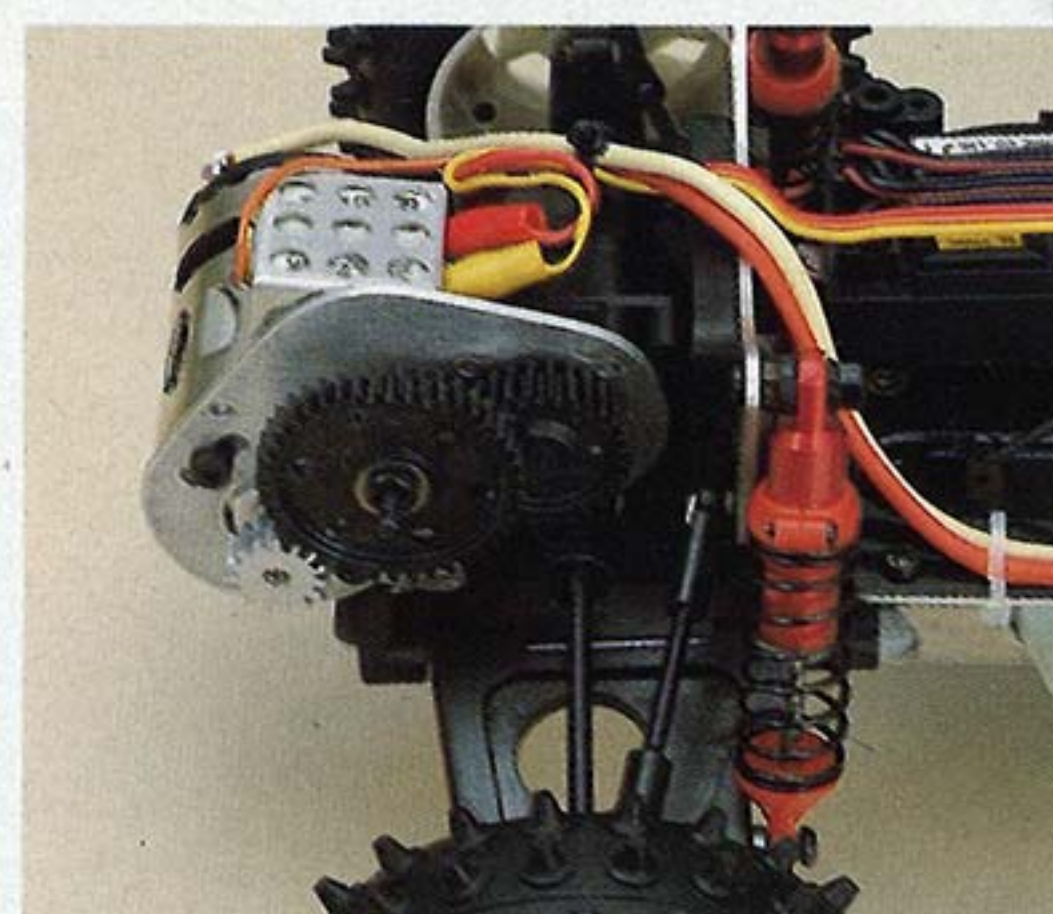

CLOSE-MOUNTED GEARBOX FOR EFFICIENCY. GEAR-TYPE DIFFERENTIAL (FACTORY MADE). CÂRTER D'ENGRENAGE INTÉGRAL POUR UNE MEILLEURE EFFICACITÉ. DIFFÉRENTIEL À ENGRENAGES, ASSEMBLÉ D'ORIGINE.





**parma**

INTERNATIONAL INC.

Team  
parma

**parma**  
INTERNATIONAL INC.

RACING WITH PARMIA  
HELGER RACING - U.K.

www.dirt-10.com



## 1987 IFMAR WORLD CHAMPIONSHIPS

### 1/10 SCALE ELECTRIC-POWERED OFF-ROAD BUGGIES



#### 2WD

1st	Joel Johnson	USA	Kyosho Ultima
2nd	Katsunori Kondo	Japan	Kyosho Ultima
3rd	Kris Moore	USA	Kyosho Ultima
4th	Mike Christensen	USA	RC 10
5th	Jamie Booth	GB	RC 10
6th	Rory Cull	GB	RC 10
7th	Kevin Moore	USA	RC 10
8th	Jay Halsey	USA	RC 10
9th	M. Hirosaka	Japan	RC 10
10th	Eustace Moore	USA	RC 10

#### 4WD

1st	Masami Hirosaka	Japan	Schumacher CAT
2nd	Katsunori Kondo	Japan	Kyosho Optima-Mid
3rd	Jamie Booth	GB	Schumacher CAT
4th	Cliff Lett	USA	Schumacher CAT
5th	Junichi Koma	Japan	Kyosho Optima-Mid
6th	Joel Johnson	USA	Kyosho Optima-Mid
7th	Jay Halsey	USA	Yokomo
8th	Pete Stevens	GB	Kyosho Optima-Mid
9th	Eric Söderquist	USA	Kyosho Optima-Mid
10th	Mike Christensen	USA	Asso RC 10/MIP

DO TOP DRIVERS CHOOSE KYOSHO?  
DO KYOSHO CARS MAKE TOP DRIVERS?



# 4WD OFF ROAD RACER

■ SHADOW 4WD ■ ROCKY 4WD ■ JAVELIN ■ OPTIMA  
■ OPTIMA PRO 4WD ■ OPTIMA MID ■ TURBO OPTIMA MID  
■ TURBO ROCKY ■ TURBO OPTIMA  
■ SALUTE ■ GALLOP MKII





# ELECTRIC POWERED RACING BUGGIES



		Length	Height	Weight	Suspension	Shock Absorber	Ball Bearing	Motor	Battery	Drive System	Option Parts
4 W D	SHADOW 4WD	400mm	160mm	1650g	(F)WS (R)WS	4 Oil-Filled Shock Absorbers	(Not included)	LeMans STOCK 05	7.2V-1200mAh	Shaft	○
	ROCKY 4WD	400mm	120mm	1600g	(F)WS (R)WS	//	4pcs.	LeMans 240ST	//	Chain	○
	JAVELIN	400mm	130mm	1630g	(F)WS (R)WS	//	4pcs.	RS-540S	7.2V-1200mAh	Chain	◎
	OPTIMA	405mm	130mm	1550g	(F)WS (R)WS	//	4pcs.	RS-540S	7.2V-1200mAh	Chain	◎
	OPTIMA PRO 4WD	390mm	120mm	1600g	(F)WS (R)WS	//	4pcs.	240,360TYPE(Not included)	7.2V-1200mAh	Chain	◎
	OPTIMA MID	350mm	130mm	1600g	(F)WS (R)WS	//	18pcs.	LeMans 240ST	7.2V-1200mAh	Belt	◎
	TURBO OPTIMA MID	350mm	130mm	1600g	(F)WS (R)WS	//	18pcs.	240,360TYPE(Not included)	7.2V-1200mAh	Belt	◎
	TURBO ROCKY	380mm	120mm	1600g	(F)WS (R)WS	//	4pcs.	240,360TYPE(Not included)	8.4V-1200mAh	Chain	◎
	TURBO OPTIMA	390mm	125mm	1700g	(F)WS (R)WS	//	18pcs.	LeMans 240ST	8.4V-1200mAh	Chain	◎
	SALUTE	390mm	130mm	1700g	(F)WS (R)WS	//	18pcs.	240,360TYPE(Not included)	8.4V-1200mAh	Chain	◎
4WDS	GALLOP MK II	410mm	170mm	1710g	(F)WS (R)TS	//	(Not included)	RS-540S	7.2V-1200mAh	Chain	○

ABBREVIATIONS : POSSIBILITY OF HOP-UP <◎=HIGH, ○=MODELATE, △=LOW> (F)=FRONT, (R)=REAR, WS=DOUBLE WISHBONES SUSPENSION, TS= TRAILING ARM SUSPENSION, SS=PILLAR-TYPE INDEPENDENT SUSPENSION.





#### THE ENTRY-LEVEL LEADER!

HIGH PERFORMANCE WITHOUT HIGH COST OR COMPLEXITY. EASY TO ASSEMBLE AND ADJUST. FOUR-WHEEL DRIVE AND FOUR-WHEEL INDEPENDENT SUSPENSION WITH QUALITY KYOSHO OIL-FILLED SHOCK ABSORBERS. MIDSHIPS MOTOR FOR OPTIMUM WEIGHT DISTRIBUTION. POWERFUL LeMANS "STOCK 05" MOTOR AND SPEED CONTROLLER INCLUDED IN KIT. STRONG ABS FRONT AND REAR WISHBONES WITH STEEL PIVOT PINS. PROTECTIVE ABS "TUB" TYPE CHASSIS. QUICK-CHANGE BATTERY HOLDER.

#### REQUIRED FOR OPERATION/SUGGESTED FOR BEST APPEARANCE

● 2-CHANNEL RADIO CONTROL SET ● 7.2V-1200mAh NiCd BATTERY PACK ● CHARGER ● POLYCA COLOR PAINT

#### Technical Data

① Length/400mm(15.7in) ② Width/244mm(9.6in) ③ Height/160mm(6.2in) ④ Wheelbase/265mm(10.4in) ⑤ Ground Clearance/32mm(1.2in) ⑥ Front Track/206mm(8.1in) ⑦ Rear Track/206mm(8.1in) ⑧ Tires/(F)85φ×38mm(3.3×1.5in); (R)85φ×38mm(3.3×1.5in) ⑨ Total Weight/1650g(58.2oz) ⑩ Gear Ratio/7.7:1 ⑪ Motor/Le Mans stock 05(Included) ⑫ Battery/7.2V-1200mAh(Not included) ⑬ Radio/2-Channel(Not included)

#### Technische Daten

① Longueur ② Largeur ③ Hauteur ④ Empattement ⑤ Garde au sol ⑥ Voie Avant ⑦ Voie Arrière ⑧ Roue ⑨ Poids Total ⑩ Proportion Dembrayage ⑪ Moteur ⑫ Nicad

#### LE CHEF DE FILE DES BUGGYS 4WD POUR DÉBUTER!

LE SHADOW EST LE MODÈLE IDÉAL POUR DÉBUTER: FACILE À ASSEMBLER ET À METTRE AU POINT. PERFORMANCES EXCELLENTE GRÂCE AU MOTEUR LeMANS 'STOCK 05' (INCLUS). SUSPENSION INDÉPENDANTE DES 4 ROUES À DOUBLES TRIANGLES ET AMORTISSEURS HYDRAULIQUES. LE SHADOW RÉUNIT LES DERNIERS PRINCIPES DE CONCEPTION, NOTAMMENT L'INSTALLATION CENTRALE DU MOTEUR ET DE LA BATTERIE EN VUE D'UNE BONNE RÉPARTITION DES MASSES. LES BRAS DE SUSPENSION AV ET AR SONT MOULÉS EN ABS POUR LA LÉGÈRETÉ ET LA SOLIDITÉ. PIVOTS EN ACIER INCASSABLES ET INUSABLES. BOÎTIER DE BATTERIE PROTECTEUR ET À REMPLACEMENT RAPIDE. LE CHÂSSIS ALUMINIUM, PROTÈGE LA RADIO DES ÉCLABOUSSURES ET DE LA POUSSIÈRE. MATÉRIAUX SÉLECTIONNÉS EN VUE DE LA PLUS GRANDE FIABILITÉ.

#### ACCESSOIRES REQUIS ET DÉCORATION SUGGÉRÉE

• ENSEMBLE RADIO 2 VOIES • BATTERIE DE COMPÉTITION 7,2V-1200mAh • CHARGEUR • PEINTURES POLYCA • FILETS DE DÉCORATION MICRONLINE •



# OFF-ROAD RACER "SHADOW 4WD," ELECTRIC POWERED SPECIAL RACING BUGGY

1:10 SCALE  
NO.3181 • 12800



- 1 LOW-PROFILE, HIGH-TRACTION TIRE.
- 2 ABS DOUBLE-WISHBONE FRONT SUSPENSION.
- 3 FRONT DIFFERENTIAL.
- 4 EFFICIENT SHAFT DRIVE.
- 5 SPEED CONTROLLER(3 FWD/ 2 REV).
- 6 LeMANS "STOCK 05" MOTOR (INCLUDED).
- 7 ABS DOUBLE-WISHBONE REAR SUSPENSION.
- 8 RESILIENT POLYPROPYLENE FRONT BUMPER.
- 9 LARGE-CAPACITY OIL-FILLED SHOCK ABSORBERS.
- 10 PROTECTIVE TUB TYPE CHASSIS.
- 11 PROTECTIVE EASY-LOADING BATTERY HOLDER.
- 12 STRONG, LIGHT POLYPROPYLENE WHEEL.

1. PNEUS À POINTES PROFIL BAS.
2. SUSPENSION AV À DOUBLES TRIANGLES EN ABS.
3. DIFFÉRENTIEL AV.
4. TRANSMISSION AV PAR AXE RIGIDE.
5. VARIATEUR À TROIS VITESSES AV ET 2 VITESSES AR.
6. MOTEUR LeMANS 'STOCK 05' (COMPRIS).
7. SUSPENSION AR À DOUBLES TRIANGLES EN ABS.
8. PARE-CHOC AV EN POLYPROPYLÈNE RENFORCÉ.
9. AMORTISSEURS HYDRAULIQUES SURDIMENSIONNÉS.
10. CHÂSSIS PROTECTEUR.
11. BOÎTIER DE BATTERIE À REMPLACEMENT INSTANTANÉ.
12. JANTES EN POLYPROPYLÈNE RENFORCÉ.

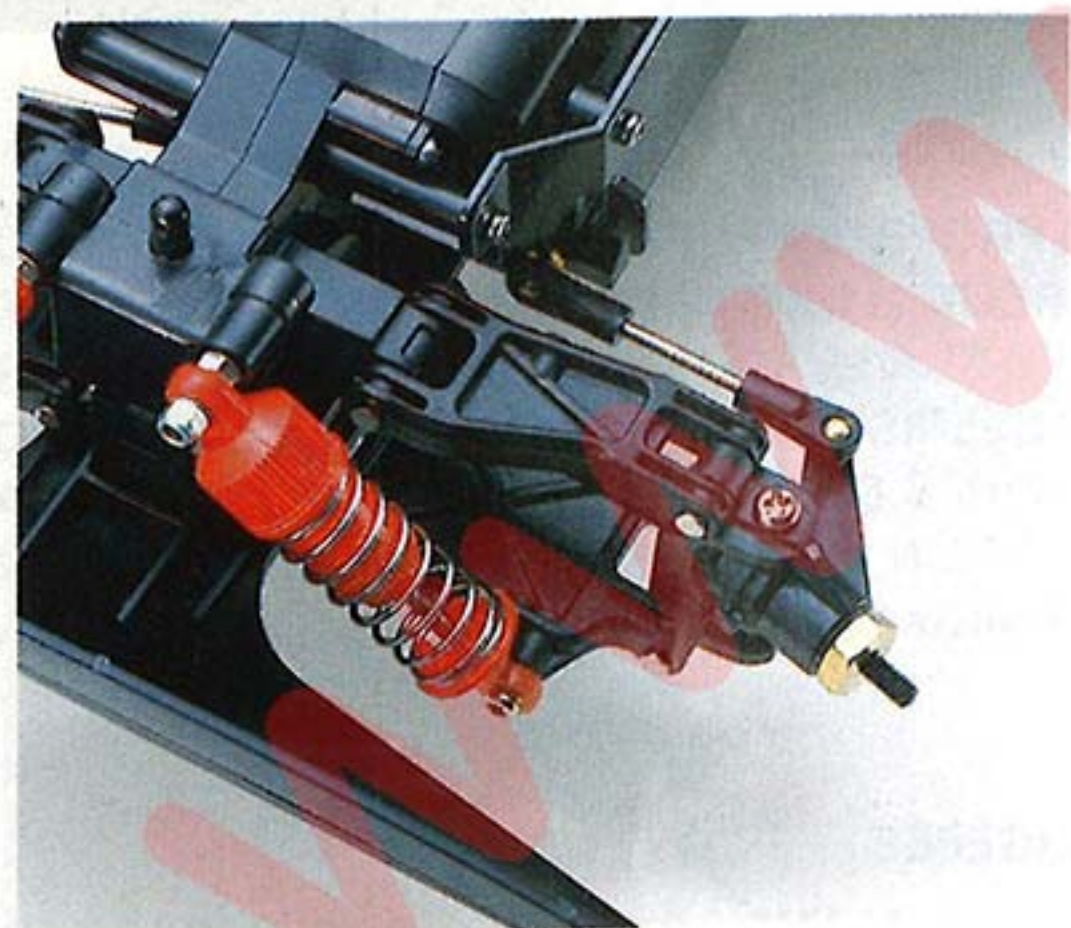
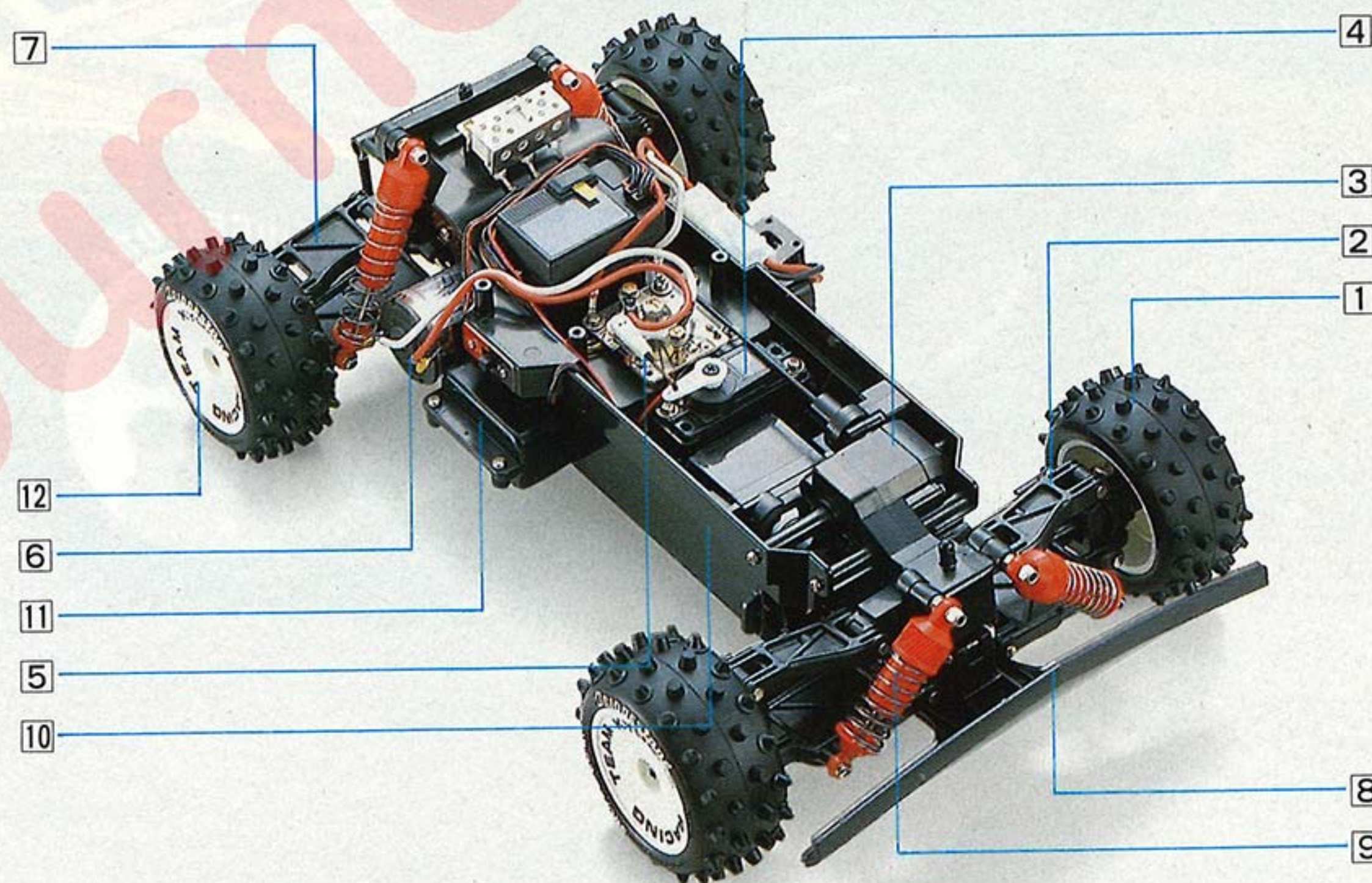

FRONT SUSPENSION. STRONG MOLDED ABS WISHBONES. LIGHT WEIGHT. LONG TRAVEL.

1. SUSPENSION AV LONGUE COURSE. BRAS MOULÉS EN ABS DE HAUTE RÉSISTANCE.

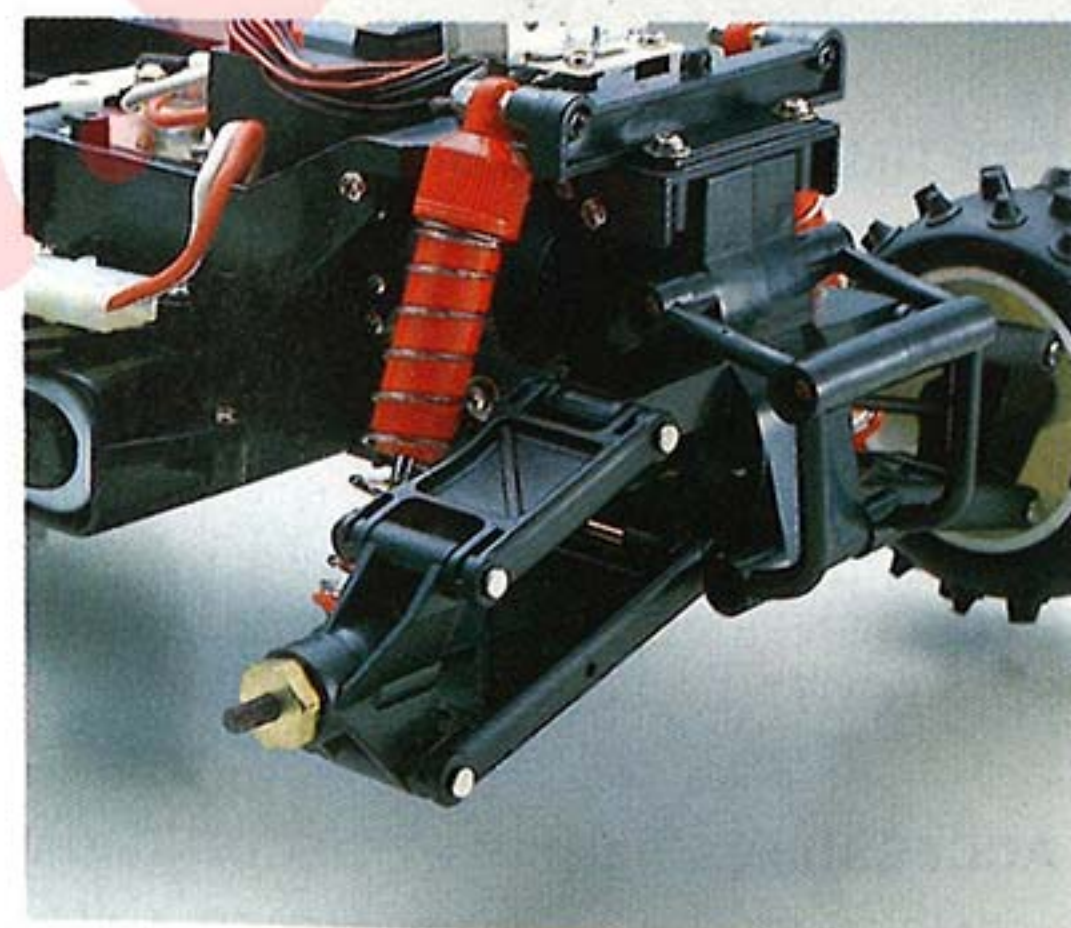

REAR SUSPENSION. SAME GOOD FEATURES AS FRONT. LARGE CAPACITY SHOCK ABSORBERS FRONT/REAR.

2. SUSPENSION AR DE MÊME CONCEPTION. AMORTISSEURS AV ET AR À HAUTE EFFICACITÉ.

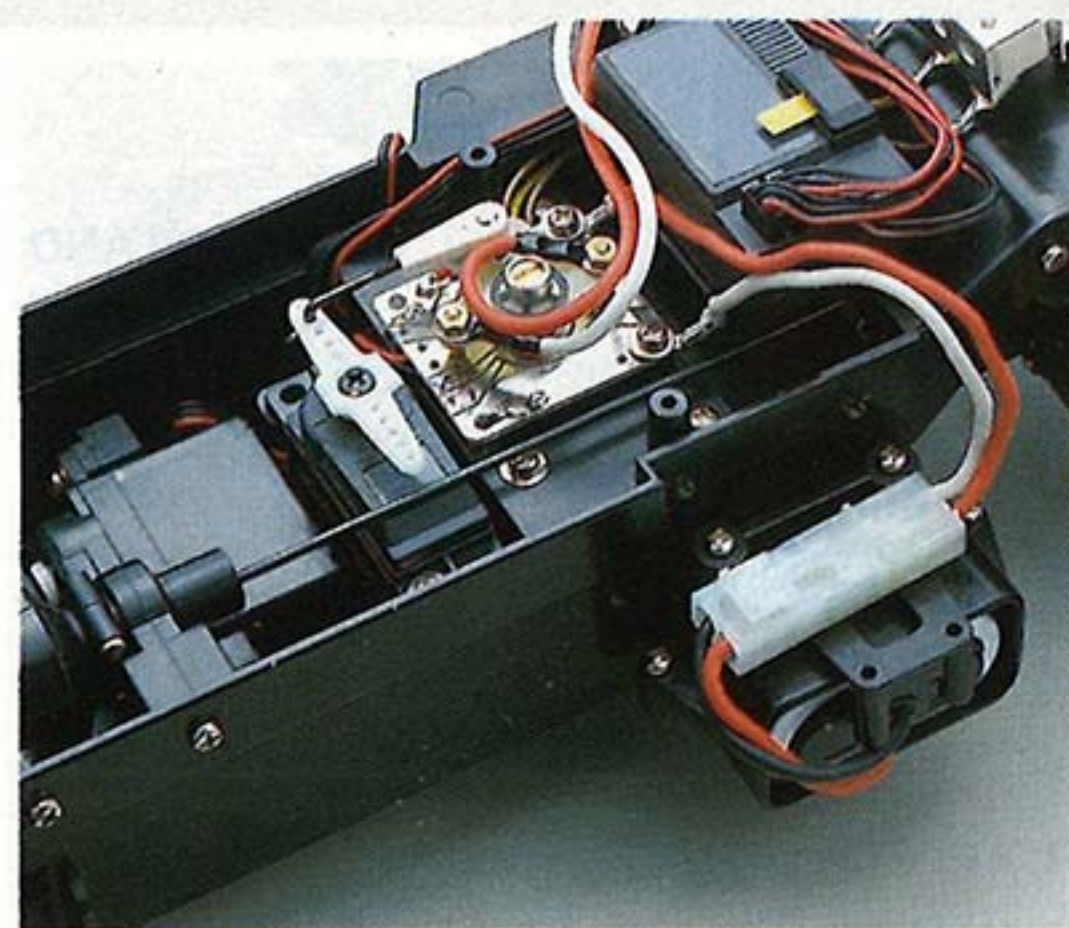

HIGH-CAPACITY SPEED CONTROLLER. THREE FORWARD SPEEDS, TWO REVERSE. SHIELDED RESISTOR.

3. VARIATEUR DE PERFORMANCE À 3 VITESSES AV, 2 VITESSES AR ET RÉSISTANCE BLINDÉE.

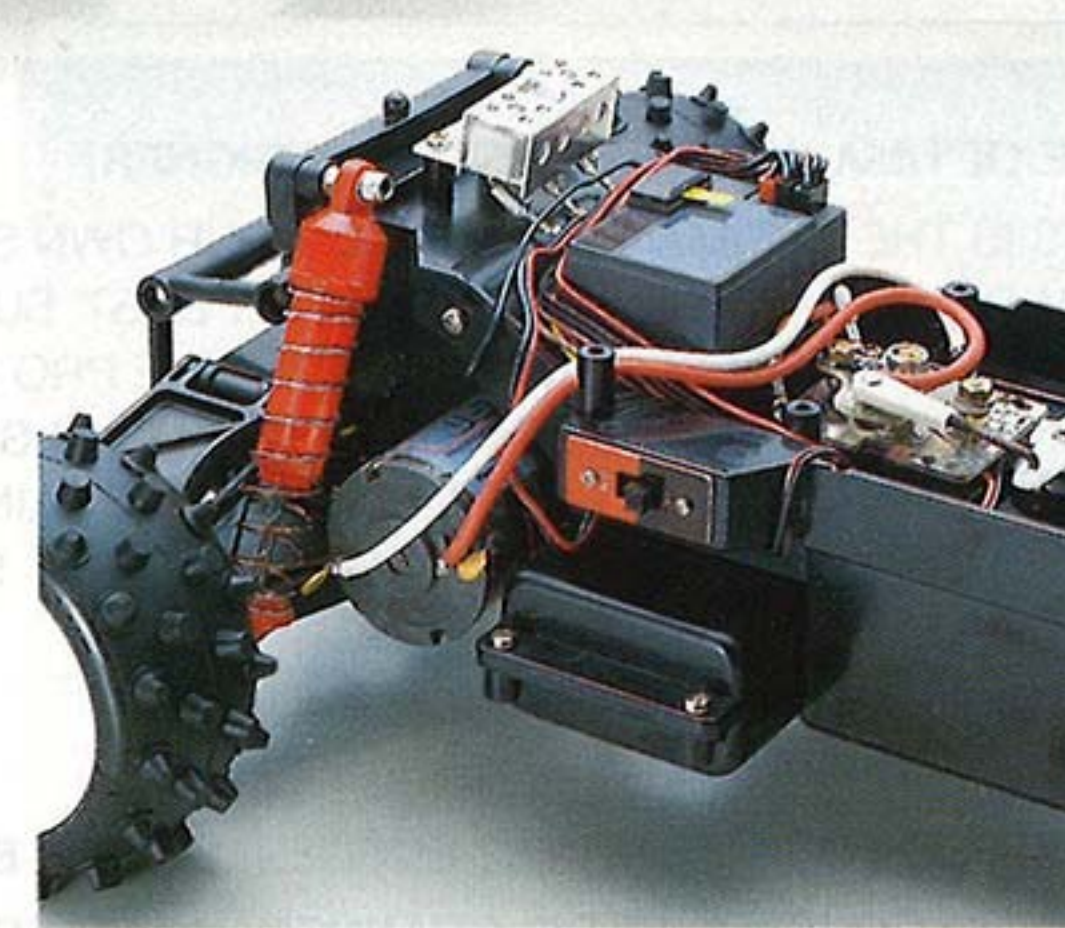

MIDSHIPS-POSITIONED MOTOR AND BATTERY FOR BEST WEIGHT DISTRIBUTION AND HANDLING.

4. MOTEUR ET BATTERIE INSTALLÉS AU CENTRE DU MODÈLE EN VUE D'UNE RÉPARTITION DES MASSES IDÉALE, ET DE LA MEILLEURE TENUE DE ROUTE.





#### THE OPTIMA FOR THE CUSTOM DESIGNER!

THIS IS THE OPTIMA TO EQUIP TO YOUR OWN SPECIFICATIONS! CHOOSE BETWEEN 7.2V AND 8.4V POWER. CHOOSE THE MOTOR BEST SUITED TO THE TRACK. CHOOSE YOUR OWN ELECTRONIC SPEED CONTROLLER. THE PRO 4WD SUPPLIES ALL THE REST OF THE TRADITIONAL OPTIMA GOODIES: THE EXTRA-LONG SUSPENSION TRAVEL THAT BANISHES BUMPS; FOUR-WHEEL DRIVE VIA LIGHTWEIGHT CHAINDRIVE SUPER-EFFECTIVE OVERSIZE SHOCK ABSORBERS; IDEAL WEIGHT DISTRIBUTION. SURE FOOTED AT ANY SPEED. A WINNER ALL THE WAY!

#### REQUIRED FOR OPERATION/SUGGESTED FOR BEST APPEARANCE

- RADIO CONTROL SET (2-CHANNEL) ● BATTERY (7.2V-1200mAh NiCd) ● BATTERY CHARGER
- POLYCA COLOR PAINT ● MICRONLINE STRIPPING TAPE

#### Technical Data

①Length/390mm(15.4in) ②Width/240mm(9.4in) ③Height/120mm(4.7in) ④Wheelbase/262mm(10.3in) ⑤Ground Clearance/35mm(1.4in) ⑥Front Track/200mm(7.9in) ⑦Rear Track/202mm(8.0in) ⑧Tires/(F)85 φ × 37mm(3.3 × 1.5in); (R)85 φ × 37mm(3.3 × 1.5in) ⑨Total Weight/1600g(56.5oz) ⑩Gear Ratio/10.3:1 ⑪Motor/Le Mans 240/360 Type(Not included) ⑫Battery/7.2V-1200mAh(Not included) ⑬Radio/2-Channel(Not included)

#### Technische Daten

①Longueur ②Largeur ③Hauteur ④Empattement ⑤Garde au sol ⑥Voie Avant ⑦Voie Arrière ⑧Roue ⑨Poids Total ⑩Proportion Dembrayage ⑪Moteur ⑫Nicad

#### L'OPTIMA, LE BUGGY SUR MESURE!

L'OPTIMA PEUT ÊTRE COMPOSÉ SELON VOS PROPRES PRÉFÉRENCES: BATTERIE 7,2 OU 8,4 VOLTS, MOTEUR SUIVANT LE TYPE DE CIRCUIT, LIBERTÉ DE CHOIX ENTRE LES DIFFÉRENTS VARIATEURS DE MARCHÉ DISPONIBLES SUR LE MARCHÉ. POUR LE RESTE LE PRO 4WD OFFRE TOUS LES RAFFINEMENTS CARACTÉRISTIQUES DE L'OPTIMA: SUSPENSION À LONGUE COURSE EN VUE D'AMORTIR LES PIRES DES CHOCS, ROUES MOTRICES PAR L'INTERMÉDIAIRE D'UNE CHAÎNE DE TRANSMISSION, AMORTISSEURS HYPER EFFICACES, EXCELLENTE RÉPARTITION DES MASSES, FORMIDABLE TENUE DE ROUTE. UN GAGNANT SUR TOUTE LA LIGNE!

#### ACCESSOIRES REQUIS ET DÉCORATION SUGGÉRÉE

- ENSEMBLE RADIO 2 VOIES ● MOTEUR (LeMANS 240 OU 360) ● BATTERIE 7,2V-1200mAh ● CHARGEUR ● PEINTURES POLYCA ● FILETS ADHÉSIFS MICRONLINE ●



# OFF-ROAD RACER "OPTIMA PRO 4WD,"

## ELECTRIC POWERED RACING BUGGY

1:10 SCALE  
NO.3029 • 16800



- 1 LOW-PROFILE SPIKE-TYPE TIRES FOR HIGH GRIP.
- 2 OVERSIZE, OIL-FILLED SHOCK ABSORBERS.
- 3 COMBINED GEARBOX/REAR DIFFERENTIAL.
- 4 ELECTRONIC SPEED CONTROLLER (NOT INCLUDED).
- 5 STRONG NYLON UPPER FRAME PLATE.
- 6 HARDENED, LIGHTWEIGHT CHAIN, SHIELDED FROM DUST.
- 7 FRONT DIFFERENTIAL.
- 8 STRONG FRONT BUMPER TO PROTECT FROM DAMAGE.
- 9 SPA 240WS OR LeMANS SPORTS H-240S MOTOR ARE RECOMMENDED (NOT INCLUDED)
- 10 WISHBONE. PARALLEL-ARM FRONT SUSPENSION.
- 11 LIGHTWEIGHT, STRONG NYLON WHEELS.
- 12 LOW-MOUNTED BATTERY 7.2V FOR LOW CG, TOP ROAD-HOLDING.
- 13 HEAVY-DUTY WISHBONE/PARALLEL-ARM FRONT SUSPENSION.

1. PNEUS À POINTES POUR UNE TRACTION OPTIMALE.
2. AMORTISSEURS HYDRAULIQUES SURDIMENSIONNÉS.
3. CARTER D'ENGRENAGE/DIFFÉRENTIEL AR COMBINÉS.
4. VARIATEUR ÉLECTRONIQUE (NON COMPRIS).
5. PLAQUE SUPÉRIEURE EN NYLON RENFORCÉ.
6. CHAÎNE DE TRANSMISSION DE QUALITÉ, CARÉNÉE.
7. DIFFÉRENTIEL AV.
8. PARE-CHOC AV DE PROTECTION CONTRE LES COLLISIONS.
9. MOTEUR SPA 240WS OU LeMANS H-240S (NON COMPRIS).
10. SUSPENSION AR À BRAS PARALLÈLES.
11. JANTES EN NYLON RENFORCÉ, TRÈS RÉSISTANTES.
12. BATTERIE 7,2 SURBAISSÉE EN VUE DE LA STABILITÉ DU MODÈLE.
13. SUSPENSION AV À BRAS PARALLÈLES.

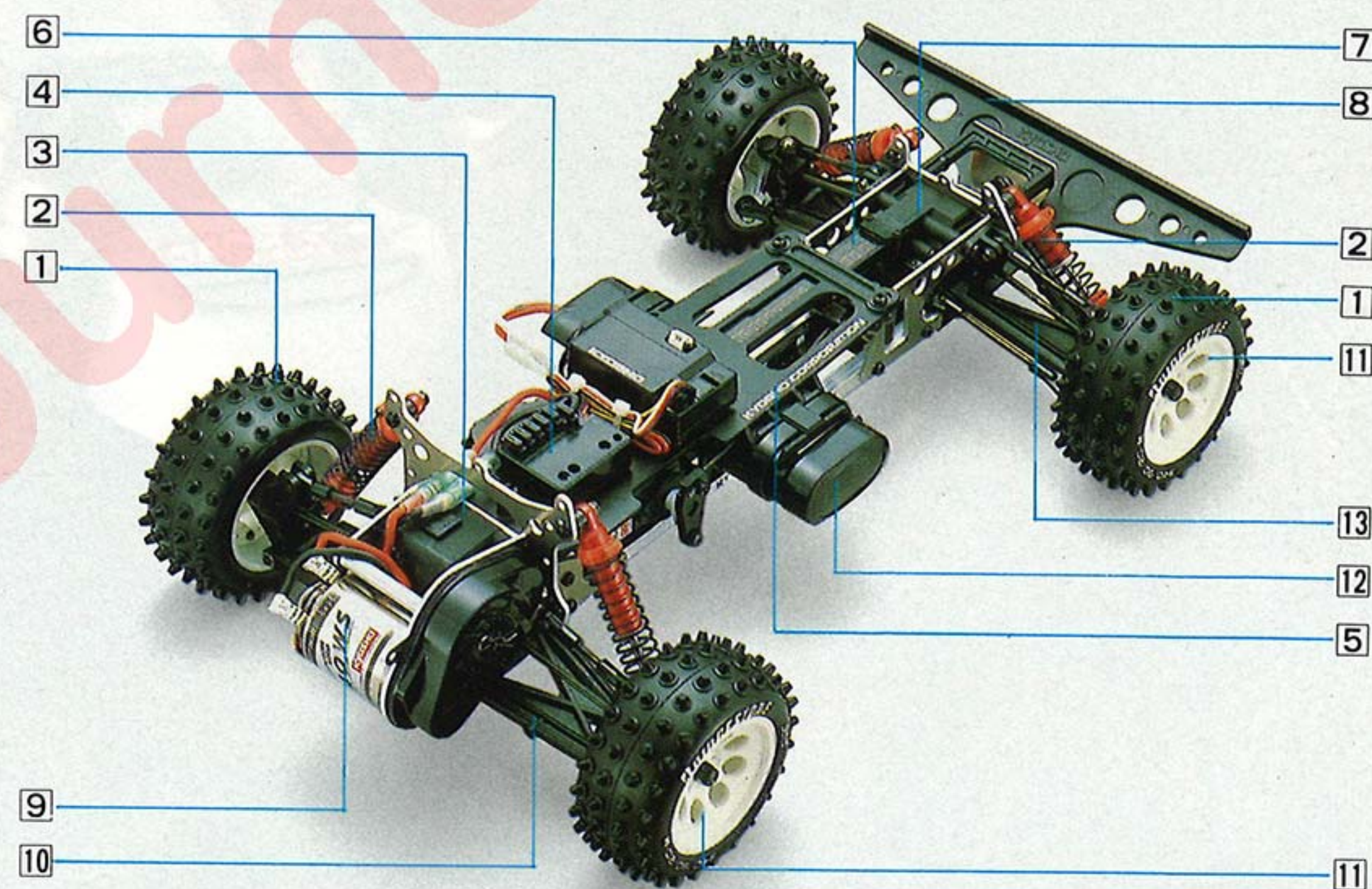

EXTRA-LONG WISHBONE/PARALLEL-ARM FRONT/REAR SUSPENSION WITH SUPER-EFFECTIVE OVERSIZE SHOCK ABSORBERS. STABLE AT ALL SPEEDS.

SUSPENSION AV ET AR À BRAS PARALLÈLES LONGUE COURSE ET AMORTISSEURS HYDRAULIQUES SURDIMENSIONNÉS, STABLE À TOUTES LES VITESSES.

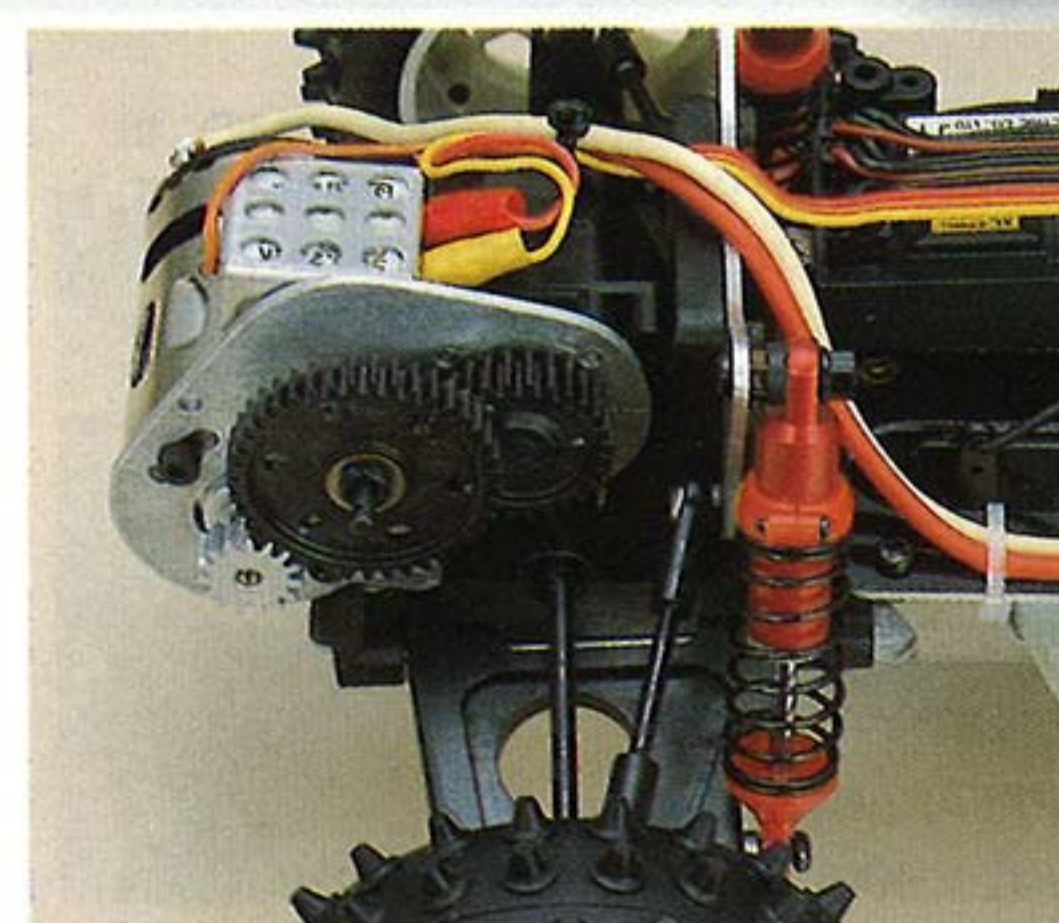

MOTOR POSITIONED FOR BEST BALANCE. SPA 240WS OR LeMANS SPORTS H-240S MOTOR CAN BE USED.

MOTEUR SPA 240WS OU LeMANS SPORT H-240S POSITIONNÉ EN VUE DE L'ÉQUILIBRE IDÉAL.



EXCITING NEW BODY SHELL. STREAMLINED AND AERODYNAMIC. CAN BE DECORATED TO DRIVER'S IMAGINATION!

NOUVELLE CARROSSERIE AÉRODYNAMIQUE PERMETTANT UNE DÉCORATION SELON L'IMAGINATION DU PILOTE.





#### THE BEST OPTIMA YET!

THE OPTIMA HAS BEEN THE TOP BUGGY SINCE ITS FIRST INTRODUCTION. THE "MID" IS THAT MUCH BETTER! FOUR-WHEEL DRIVE BY EFFICIENT, LIGHTWEIGHT TOOTHED BELT. BALL BEARINGS (18) SUPPLIED. POWERFUL LeMANS 240ST MOTOR AND SPEED CONTROLLER INCLUDED. STRONG ALLOY ALUMINUM CHASSIS. GLASS-REINFORCED SUSPENSION PARTS. EXTRALength, LONG-TRAVEL (35MM) ALL-INDEPENDENT SUSPENSION. MOTOR POSITIONED FOR OPTIMUM BALANCE. OVERSIZE SHOCKS. A SURE WINNER!

#### REQUIRED FOR OPERATION/SUGGESTED FOR BEST APPEARANCE

- RADIO CONTROL SET (2-CHANNEL) ● BATTERY (7.2V-1200mAh NiCd) ● BATTERY CHARGER
- POLYCA COLOR PAINT ● MICRONLINE STRIPPING TAPE

#### Technical Data

①Length/350mm(13.8in)②Width/240mm(13.4in)③Height/130mm(5.1in)④Wheelbase/255mm(10.0in)⑤Ground Clearance/35mm(1.4in)⑥Front Track/200mm(7.9in)⑦Rear Track/202mm(7.9in)⑧Tires/(F)85φ×37mm(3.3×1.5in);(R)85φ×37mm(3.3×1.5in)⑨Total Weight/1600g(56.4oz)⑩Grea Ratio/9.78:1⑪Motor/Le Mans 240ST(Included)⑫Battery/7.2V-1200mAh(Not included)⑬Radio/2-Channel(Not included)

#### Technische Daten

①Longueur②Largeur③Hauteur④Empattement⑤Garde au sol⑥Voie Avant⑦Voie Arrière⑧Roue⑨Poids Total⑩Proportion Dembrayage⑪Moteur⑫Nicad

#### LE MEILLEUR OPTIMA!

L'OPTIMA VIENT D'ÊTRE AMÉLIORÉ! OUTRE L'AVANTAGE DE LA SUSPENSION LONGUE COURSE, QUI REND L'OPTIMA CÉLÈBRE, LE MODÈLE DISPOSE À PRÉSENT D'UNE TRANSMISSION AMÉLIORÉE VERS LES ROUES AV ET AR: UNE COURROIE LÉGÈRE, ANTIDÉRAPANTE ET RENFORCÉE EN VUE DE RÉDUIRE LA DILATATION. LE MODÈLE EST POURVU DES MEILLEURES ÉVOLUTIONS TECHNIQUES: 18 ROULEMENTS À BILLES, MOTEUR PUISSANT LeMANS 240ST, VARIATEUR DE VITESSE, AMORTISSEURS HYDRAULIQUES SURDIMENSIONNÉS, CHÂSSIS ULTRA RIGIDE EN ALLIAGE D'ALUMINIUM, ET SUSPENSION RENFORCÉE FIBRE DE VERRE. AU PRIX DE QUELQUES HEURES D'ASSEMBLAGE (GRÂCE À L'EXCELLENT MANUEL) VOUS DISPOSEREZ DU MEILLEUR MODÈLE DU CIRCUIT: LORS DES CHAMPIONNATS DU MONDE 1987 CINQ DES DIX FINALISTES ÉTAIENT DES OPTIMA MIDS!

#### ACCESSOIRES REQUIS ET DÉCORATION SUGGÉRÉE

- ENSEMBLE RADIO 2 VOIES ● BATTERIE DE COMPÉTITION NiCad 7,2V-1200mAh ●
- CHARGEUR ● PEINTURES POLYCA ● FILETS ADHÉSIFS MICRONLINE ●



# 4WD OFF-ROAD RACER "OPTIMA MID," ELECTRIC POWERED SPECIAL RACING BUGGY

1:10 SCALE  
NO.3135 • 24800



- 1] PRESSURE-TYPE OIL-FILLED SHOCK ABSORBER (x 4).
- 2] FRONT DIFFERENTIAL. METAL GEARS.
- 3] FRP UPPER CHASSIS PLATE WITH BELT SHIELD (TOTAL ENCLOSURE).
- 4] REINFORCED MATERIAL TOOTHED DRIVE BELT.
- 5] AERODYNAMIC ADJUSTABLE WING.
- 6] LOW-PROFILE TIRES WITH HIGH-GRIP SPIKE TREAD.
- 7] RACING-TYPE FRONT BUMPER.
- 8] WISHBONE/PARALLEL ARM FRONT SUSPENSION. GLASS FILLED EX66 NYLON.
- 9] ALLOY ALUMINUM CHASSIS PLATE.
- 10] SPEED CONTROLLER (3 SPEEDS: INCLUDED IN KIT)
- 11] BATTERY. (7.2V-1200mAh NiCd; NOT INCLUDED.)
- 12] LONG-TRAVEL WISHBONE/PARALLEL ARM REAR SUSPENSION.
- 13] LIGHTWEIGHT NYLON WHEEL.

1. QUATRE AMORTISSEURS HYDRAULIQUES.
2. DIFFÉRENTIEL AV, PIGNONS EN MÉTAL.
3. PLAQUE SUPÉRIEURE DU CHÂSSIS EN FRP, CARÉNAGE DE COURROIE.
4. COURROIE CRANTÉE RENFORCÉE.
5. AILERON AÉRODYNAMIQUE RÉGLABLE.
6. PNEUS À POINTES PROFIL BAS.
7. PARE-CHOC AV TYPE COMPÉTITION.
8. SUSPENSION AV À DOUBLES TRIANGLES EN NYLON EX66.
9. CHÂSSIS EN ALLIAGE D'ALUMINIUM.
10. VARIATEUR À TROIS POSITIONS (INCLUS).
11. BATTERIE 7,2V-1200mAh NiCad (NON COMPRIS).
12. SUSPENSION AR À TRIANGLES PARALLÈLES LONGUE COURSE.
13. JANTES LÉGÈRES EN NYLON.

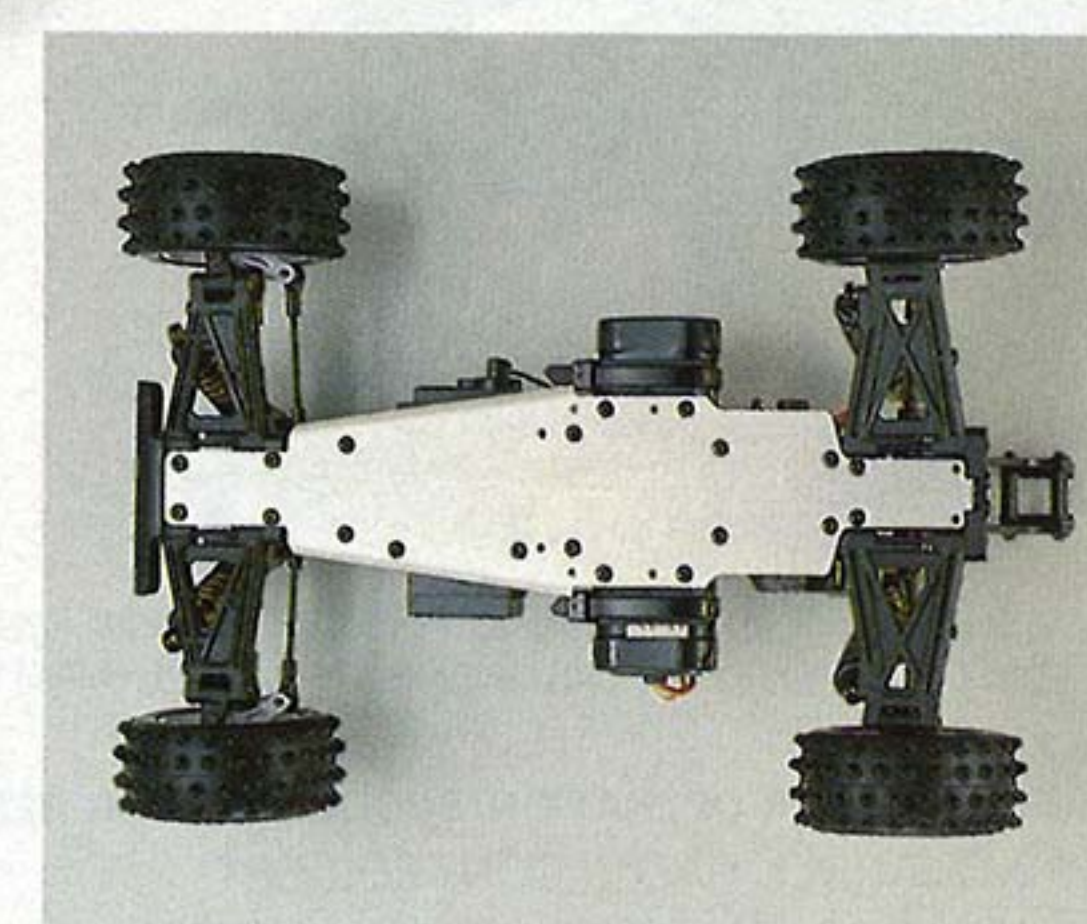
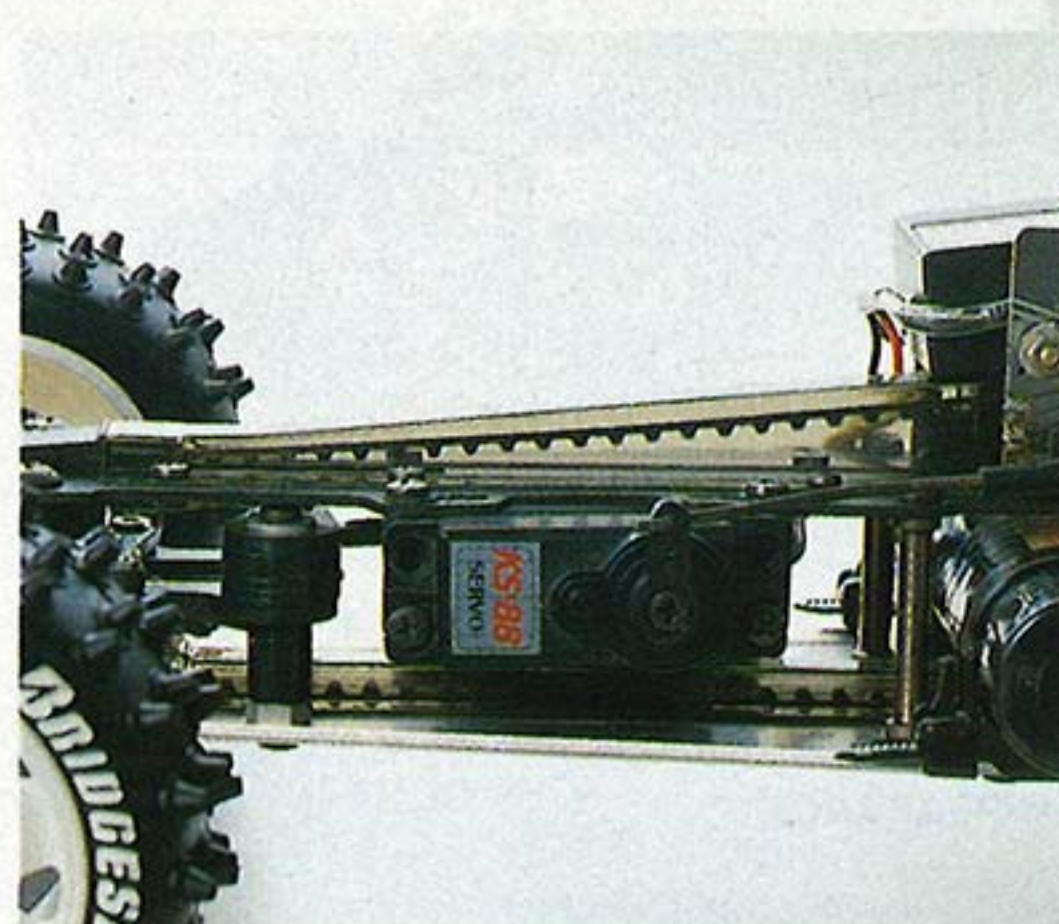
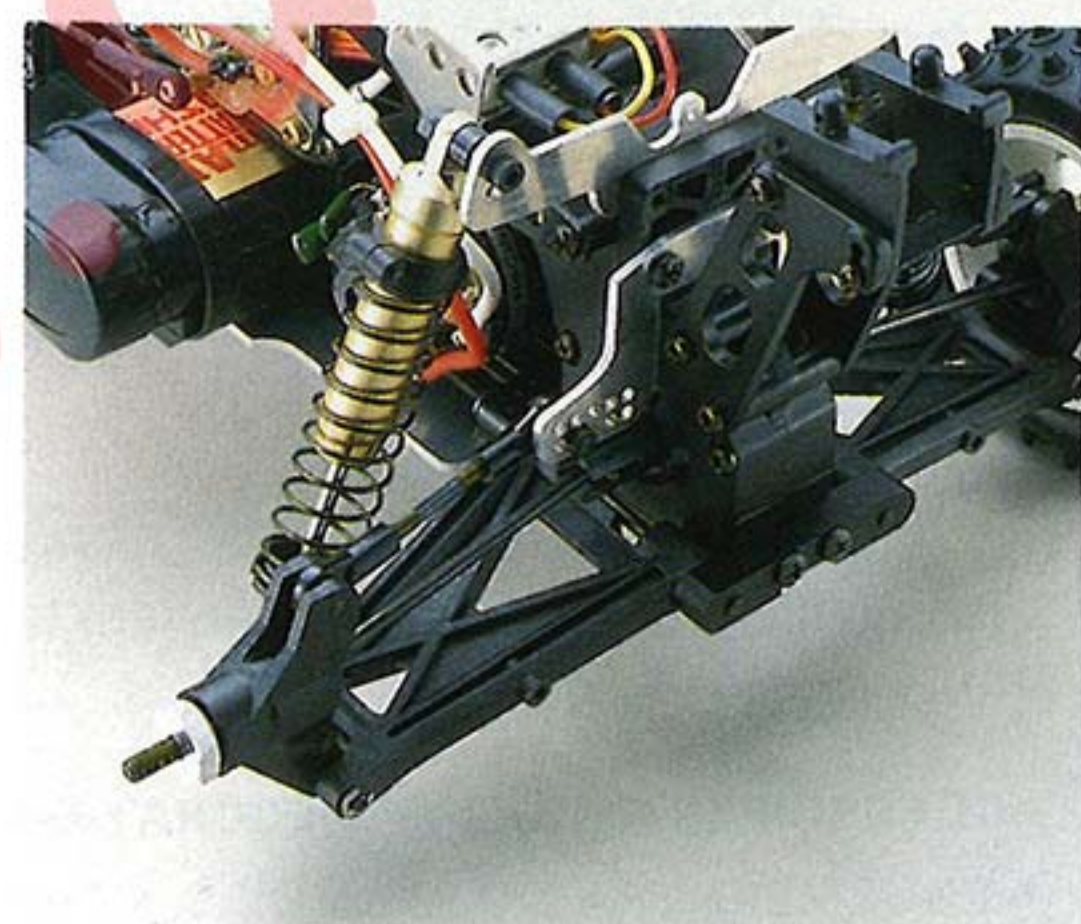
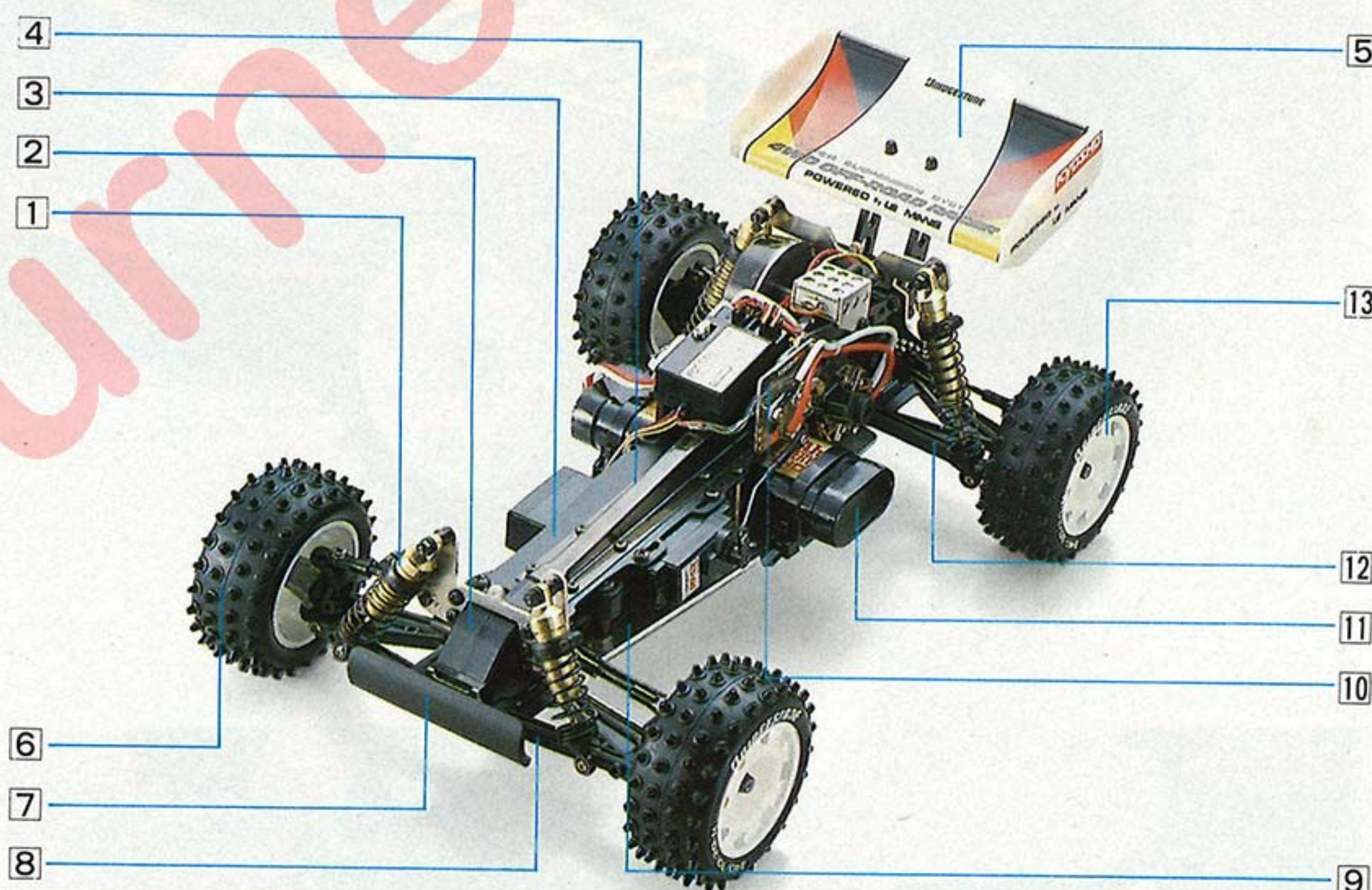

EXTRA-LENGTH WISHBONE/ARM FRONT SUSPENSION FOR LONG TRAVEL. REAR SUSPENSION (SAME FEATURES AS FRONT). BOTH F/R HAVE PRESSURE SHOCK AND ADJUSTABLE GEOMETRY.

SUSPENSION AV SURDIMENSIONNÉE LONGUE COURSE. SUSPENSION AR DE MÊME CONCEPTION. AMORTISSEURS À PRESSION ET À GÉOMÉTRIE VARIABLE.

TOOTHED DRIVE BELT. LIGHT, STRONG, RELIABLE. REINFORCED MATERIAL TO PREVENT STRETCHING.

COURROIE DE TRANSMISSION CRANTÉE EN MATIÈRE SOLIDE, LÉGÈRE ET FIABLE, RENFORCÉE EN VUE D'EMPÊCHER DE SE DÉTENDRE.

ALLOY ALUMINUM PLATE-TYPE CHASSIS. STRONG. LIGHT.

CHÂSSIS EN TÔLE D'ALUMINIUM RÉSISTANT ET LÉGÈRE.



# 4WD OFF-ROAD RACER "TURBO OPTIMA MID," ELECTRIC POWERED RACING BUGGY

1:10 SCALE  
NO.3136 • 26800



## THE CUSTOM BUILDER'S OPTIMA!

THE "MID" HAS ALL THE GREAT FEATURES OF THE STANDARD OPTIMA, BUT ALLOWS THE MODELLER TO SELECT THE ELECTRONIC SPEED CONTROLLER AND MOTOR. (OPTIMUM MOTORS ARE LeMANS 240 AND 360 SERIES.) KIT HAS ALL USUAL OPTIMA FEATURES: LONG-TRAVEL ALL-INDEPENDENT SUSPENSION F/R, FOUR-WHEEL DRIVE BY TOOTHED BELT AND TWO DIFFS, "PRESSURE" SHOCKS, ANTI-SWAY BARS, 18 BALL BEARING, AND MORE.

## L'OPTIMA SUR MESURE!

LA MID EST UNE OPTIMA STANDARD QUI PERMET AU CONSTRUCTEUR DE CHOISIR LE MOTEUR ET LE VARIATEUR ÉLECTRONIQUE. (MOTEURS RECOMMANDÉS: LeMANS 240 ET 360). LE KIT DISPOSE DE TOUTES LES CARACTÉRISTIQUES DE L'OPTIMA HABITUELLE: SUSPENSION INDÉPENDANTE À LONGUE COURSE AV ET AR, QUATRE ROUES MOTRICES PAR L'INTERMÉDIAIRE DE 2 DIFFÉRENTIELS ET UNE COURROIE CRANTÉE, AMORTISSEURS À PRESSION, STABILISATEURS, 18 ROULEMENTS À BILLES, ETC.



WISHBONE/PARALLEL-ARM FRONT SUSPENSION. ANTI-SWAY BAR. QUICK ADJUST. UNIVERSAL-JOINT HALFSHAFT. WISHBONE/PARALLEL ARM REAR SUSPENSION.

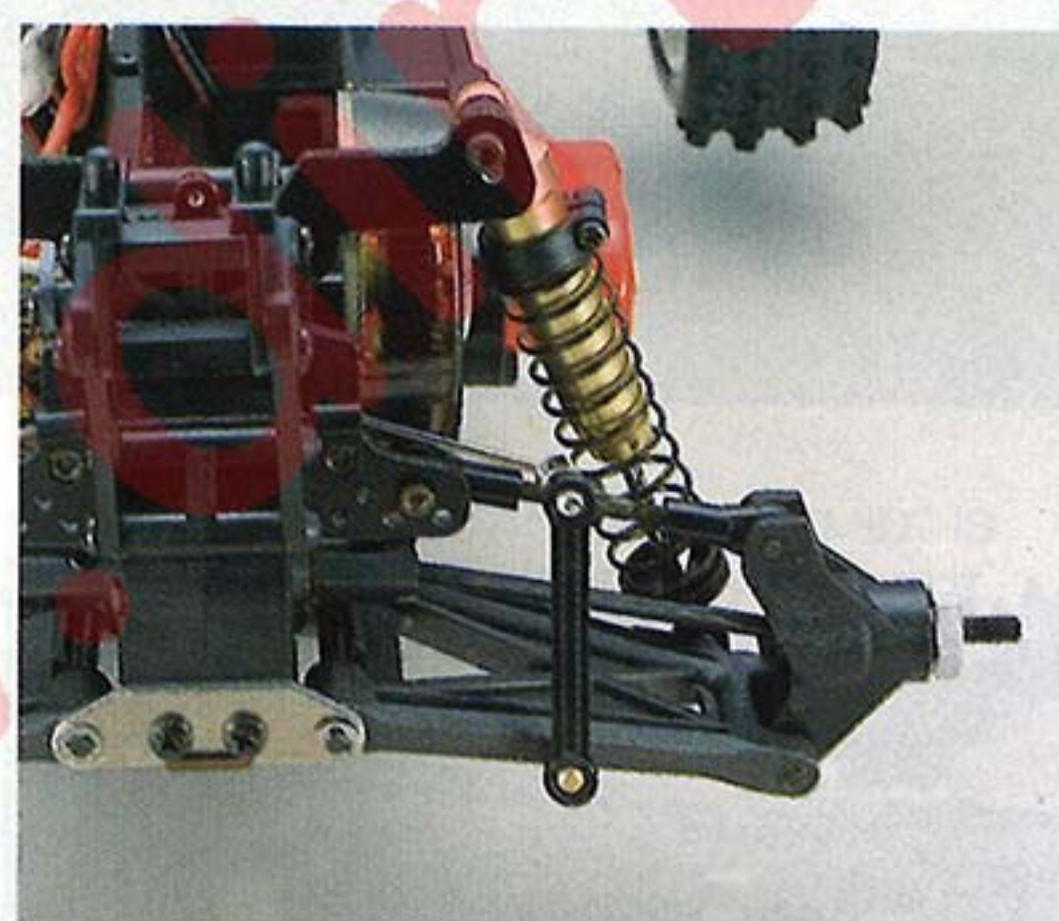

INTERNAL TORQUE LIMITER PREVENTS MOTOR DAMAGE IF WHEELS JAM.

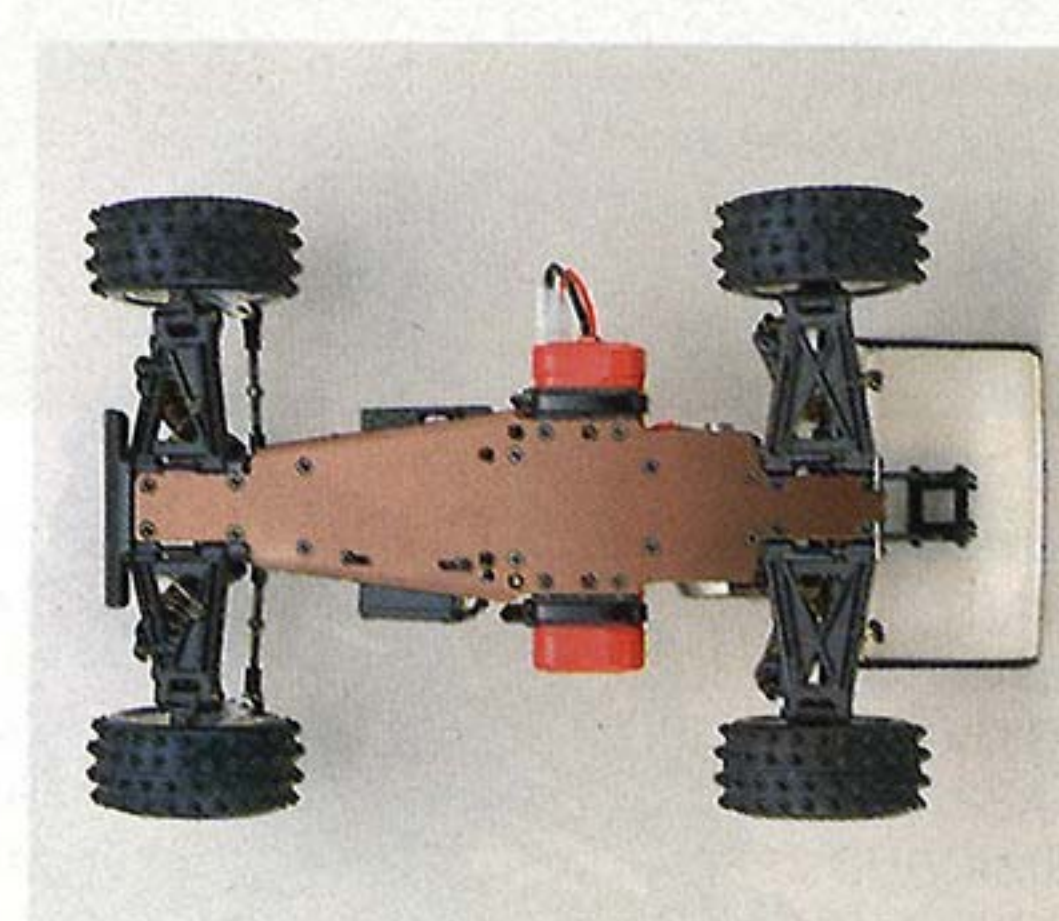

2.3MM ALLOY ALUMINUM PLATE-TYPE CHASSIS. STRONG. LIGHT.

## REQUIRED FOR OPERATION/SUGGESTED FOR BEST APPEARANCE

- 2-CHANNEL RADIO CONTROL SET
- 7.2V-1200mAh NiCd BATTERY PACK
- CHARGER • MOTOR • POLYCA COLOR PAINT

## Technical Data

①Length/350mm(13.8in) ②Width/240mm(13.4in) ③Height/130mm(5.1in) ④Wheelbase/255mm(10.0in) ⑤Ground Clearance/35mm(1.4in) ⑥Front Track/200mm(7.9in) ⑦Rear Track/202mm(7.9in) ⑧Tires/(F)85φ×37mm(3.3×1.5in);(R)85φ×37mm(3.3×1.5in) ⑨Total Weight/1600g(56.4oz) ⑩Gear Ratio/9.78:1 ⑪Motor/Le Mans 240/360Type(Not included) ⑫Battery/7.2V-1200mAh(Not included) ⑬Radio/2-Channel(Not included)

## Technische Daten

①Longueur ②Largeur ③Hauteur ④Empattement ⑤Garde au sol ⑥Voie Avant ⑦Voie Arrière ⑧Roue ⑨Poids Total ⑩Proportion Dembrayage ⑪Moteur ⑫Nicad

## ACCESSOIRES REQUIS ET DÉCORATION SUGGÉRÉE

- ENSEMBLE RADIO 2 VOIES • MOTEUR (LeMANS 240 OU 360) • BATTERIE 7,2V-1200mAh • CHARGEUR • PEINTURES POLYCA • FILETS ADHÉSIFS MICRONLINE •









#### THE 4WD ELECTRIC OFF-ROADER WITH EVERYTHING OPTIMIZED FOR GO.

OPTIMA IS DESIGNED FOR ONLY ONE PURPOSE WINNING! EXTRA-LONG WISHBONES OF THE FRONT AND REAR SUSPENSION PLUS OIL-FILLED SHOCKS IRON OUT THE BUMPS AND VIRTUALLY ELIMINATE ANY CHANGE OF STEERING ANGLE DUE TO BUMPS. DIFFERENTIALS FRONT AND REAR GET THE POWER TO THE GROUND, AND THE SELECTABLE POWER BIAS GIVES THE CHOICE OF EQUAL POWER TO ALL WHEELS OR MORE TO THE FRONT WHEELS. ALL MATERIALS CHOSEN FOR HIGH STRENGTH.

#### LE BUGGY 4WD ÉLECTRIQUE ÉTUDIÉ DANS TOUS SES DÉTAILS

L'OPTIMA FUT CONÇU DANS UN SEUL BUT: CELUI DE GAGNER DES COURSES! LES ÉNORMES BRAS DE SUSPENSION ET LES AMORTISSEURS COMPENSENT TOUS LES EFFETS DES IRRÉGULARITÉS DE TERRAIN, ET NOTAMMENT L'INSTABILITÉ DE LA TRAJECTOIRE. LES DEUX DIFFÉRENTIELS ASSURENT UNE TRACTION CONSTANTE DES 4 ROUES, ET LE CHOIX ENTRE DEUX RAPPORTS DIFFÉRENTS POUR LES ROUES AV PERMET SOIT D'OBTENIR UNE TRACTION ÉGALE DES 4 ROUES, SOIT DE FAVORISER LA TRACTION À L'AVANT. TOUS LES MATÉRIEAUX SONT SÉLECTIONNÉS EN VUE DE LA PLUS HAUTE FIABILITÉ.

#### REQUIRED FOR OPERATION/SUGGESTED FOR BEST APPEARANCE

● 2-CHANNEL RADIO CONTROL SET ● 7.2V-1200mAh NiCd RACING BATTERY ● BATTERY CHARGER ● POLYCA COLOR PAINTS ● MICRONLINE STRIPPING TAPE

#### Technical Data

①Length/405mm(15.9in)②Width/240mm(9.4in)③Height/130mm(5.1in)④Wheelbase/268mm(10.6in)⑤Ground Clearance/36mm(1.4in)⑥Front Track/194mm(7.6in)⑦Rear Track/196mm(7.7in)⑧Tires/(F)85φ×35mm(3.3×1.4in);(R)85φ×35mm(3.3×1.4in)⑨Total Weight/1550g(55.0oz)⑩Gear Ratio/8.28:1,10.35:1⑪Motor/RS-540S(Included)⑫Battery/7.2V-1200mAh(Not included)⑬Radio/2-Channel(Not included)

#### Technische Daten

①Longueur②Largeur③Hauteur④Empattement⑤Garde au sol⑥Voie Avant⑦Voie Arrière⑧Roue⑨Poids Total⑩Proportion Dembrayage⑪Moteur⑫Nicaid

#### ACCESSOIRES REQUIS ET DÉCORATION SUGGÉRÉE

● ENSEMBLE RADIO 2 VOIES ● BATTERIE DE COMPÉTITION NiCad 7,2V-1200mAh ● CHARGEUR ● PEINTURES POLYCA ●



## 4WD OFF-ROAD RACER "OPTIMA,"

ELECTRIC POWERED 4WD RACING BUGGY

NO.3032 • 21800

## 4WD OFF-ROAD RACER "JAVELIN,"

ELECTRIC POWERED 4WD RACING BUGGY

NO.3031 • 22800

1:10 SCALE



- 1 SHOCK-RESISTANT GLASS-FILLED 66EX NYLON BUMPER.
- 2 10×25mm STROKE OIL-FILLED FRONT SHOCKS.
- 3 EXTRA LONG 66EX FRONT WISHBONES FOR NIL STEERING CHANGE ON BUMPS.
- 4 10×39mm STROKE OIL-FILLED REAR SHOCKS.
- 5 STYLISH HIGH-STRENGTH NYLON WHEELS.
- 6 NEW PATTERN SPIKE TIRES OPTIMIZED FOR 4WD.
- 7 SHIELD TUBE FOR LONGER CHAIN LIFE.
- 8 SPECIAL LOW-RESISTANCE SPEED CONTROLLER.
- 9 REAR MOTOR FOR 50-50 BALANCE, EASY ACCESS.
- 10 EXTRA LONG 66EX REAR WISHBONES.

1. PARE-CHOC EN NYLON 66EX RENFORCÉ FIBRE DE VERRE.
2. AMORTISSEURS HYDRAULIQUES AV 10×25mm.
3. BRAS DE SUSPENSION AV EN NYLON 66EX EXTRA LONGS POUR UNE MEILLEURE STABILITÉ DE TRAJECTOIRE.
4. AMORTISSEURS HYDRAULIQUES AR 10×39mm.
5. JANTES EN NYLON RENFORCÉ.
6. NOUVEAU TYPE DE PNEUS À POINTES POUR LE 4WD.
7. PROTECTION DE LA CHAÎNE.
8. VARIATEUR SPÉCIAL À GRAND DÉBIT.
9. MOTEUR À L'ARRIÈRE EN VUE DU PARFAIT ÉQUILIBRE ET BIEN ACCESSIBLE.
10. BRAS DE SUSPENSION AR EXTRA LONGS EN NYLON EX66.

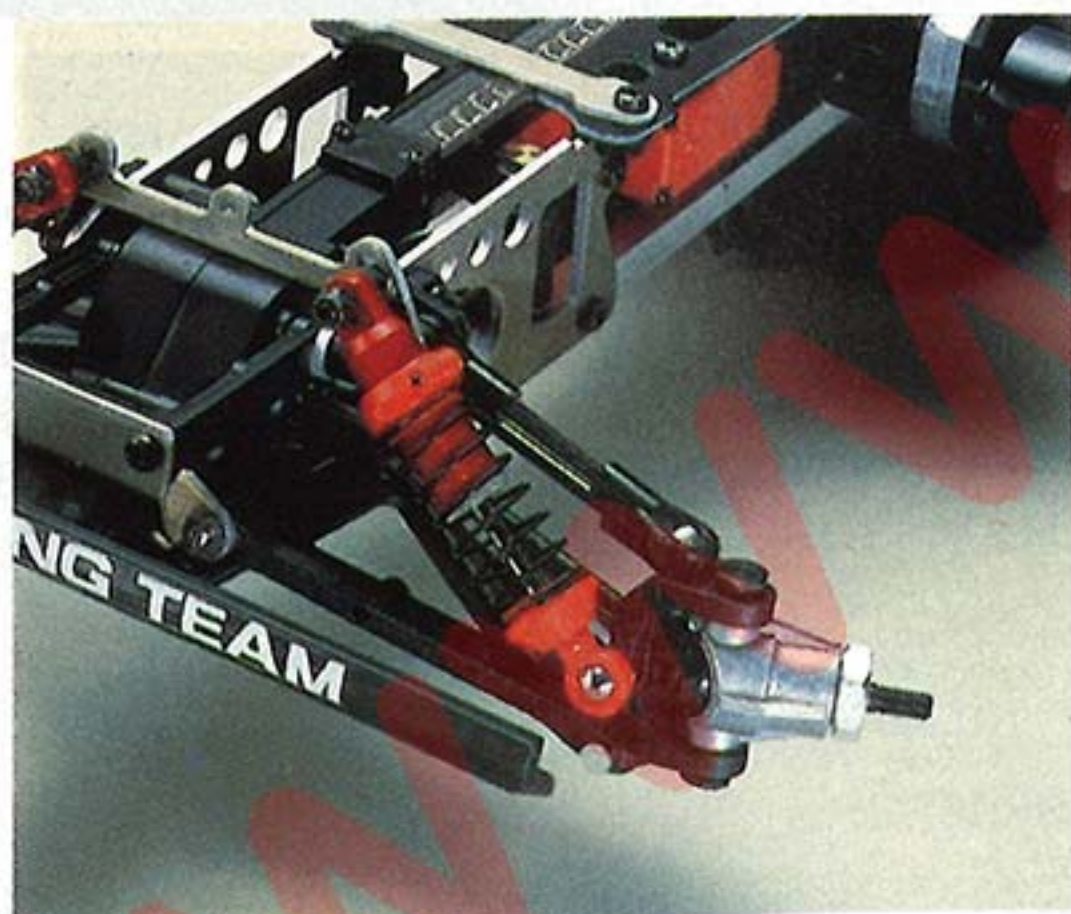
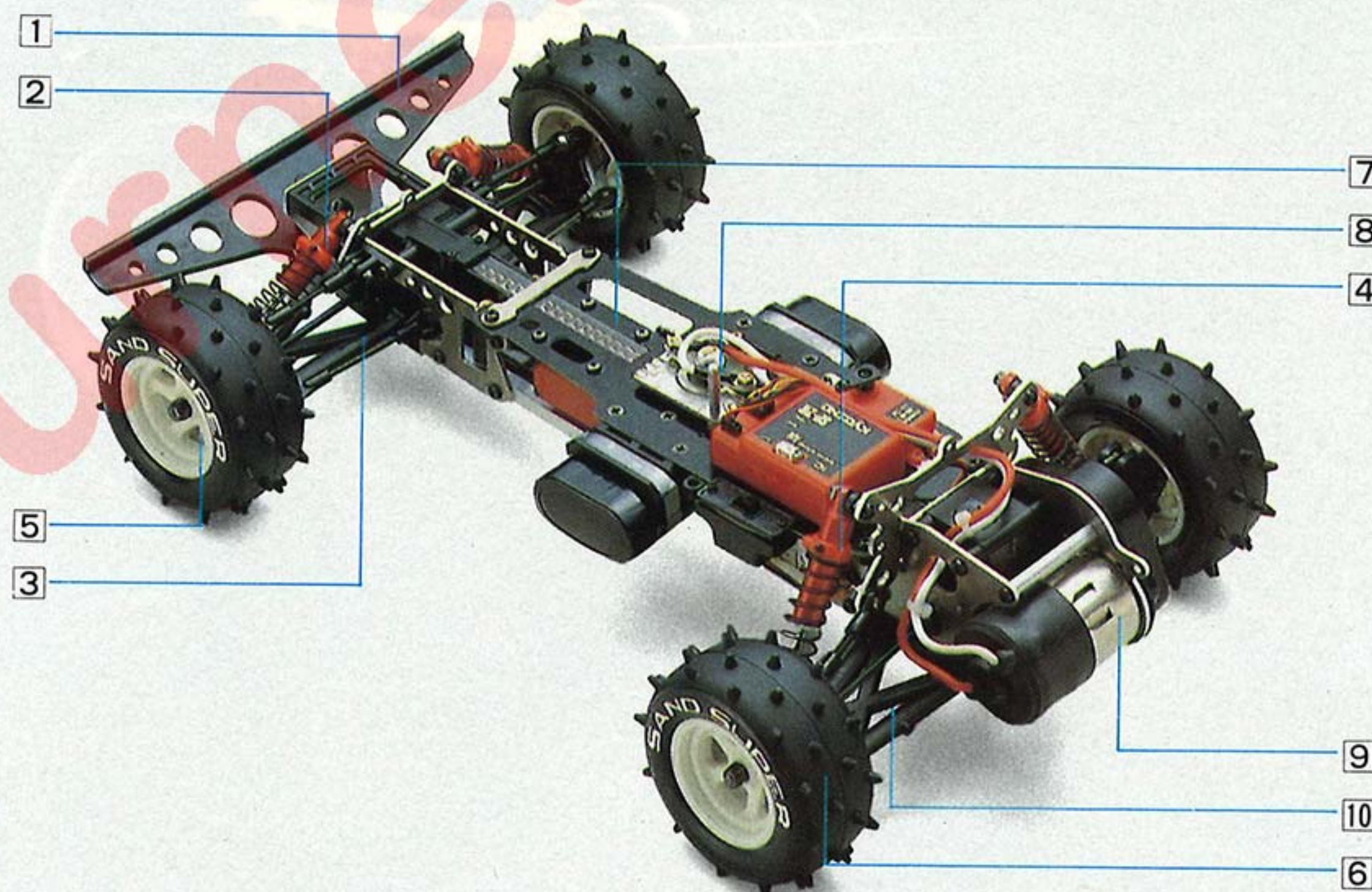

WISHBONES ARE EXTRA LONG FOR TOP HANDLING IN THE ROUGH.

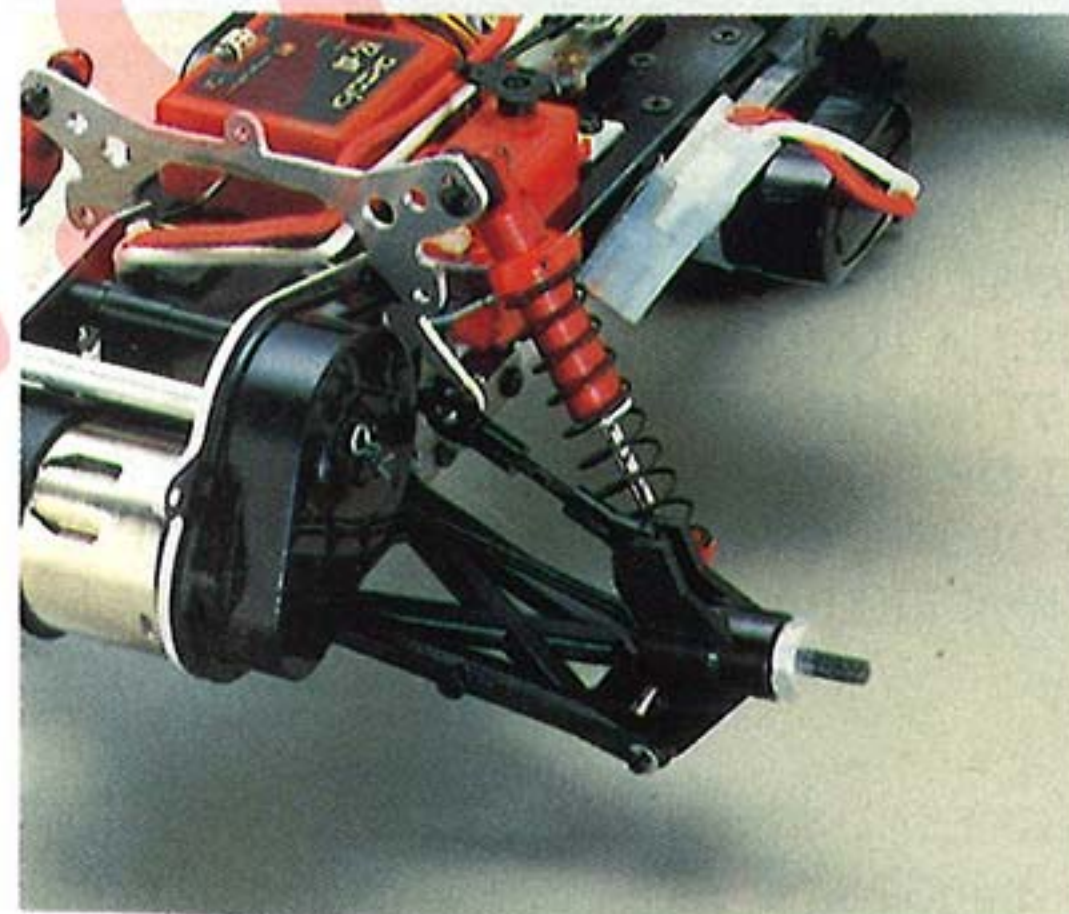

SUSPENSION LONGUE COURSE, IDÉALE SUR TERRAINS TRÈS ACCIDENTÉS.

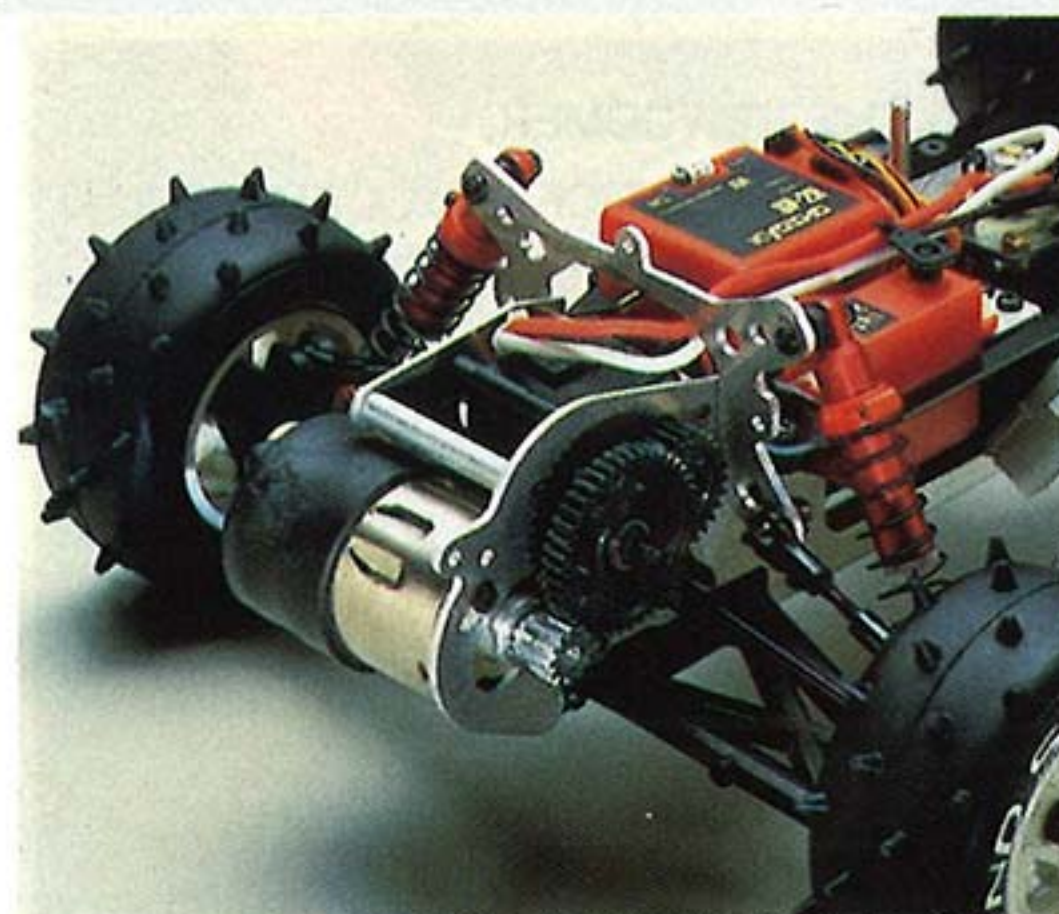

PRECISION MOLDED GEARS (UNCOVERED FOR PHOTO) TRANSMIT POWER SMOOTHLY.

TRANSMISSION À GRAND RENDEMENT PAR ENGRENAGES DE PRÉCISION MOULÉS (OUVERT POUR LA PHOTO).

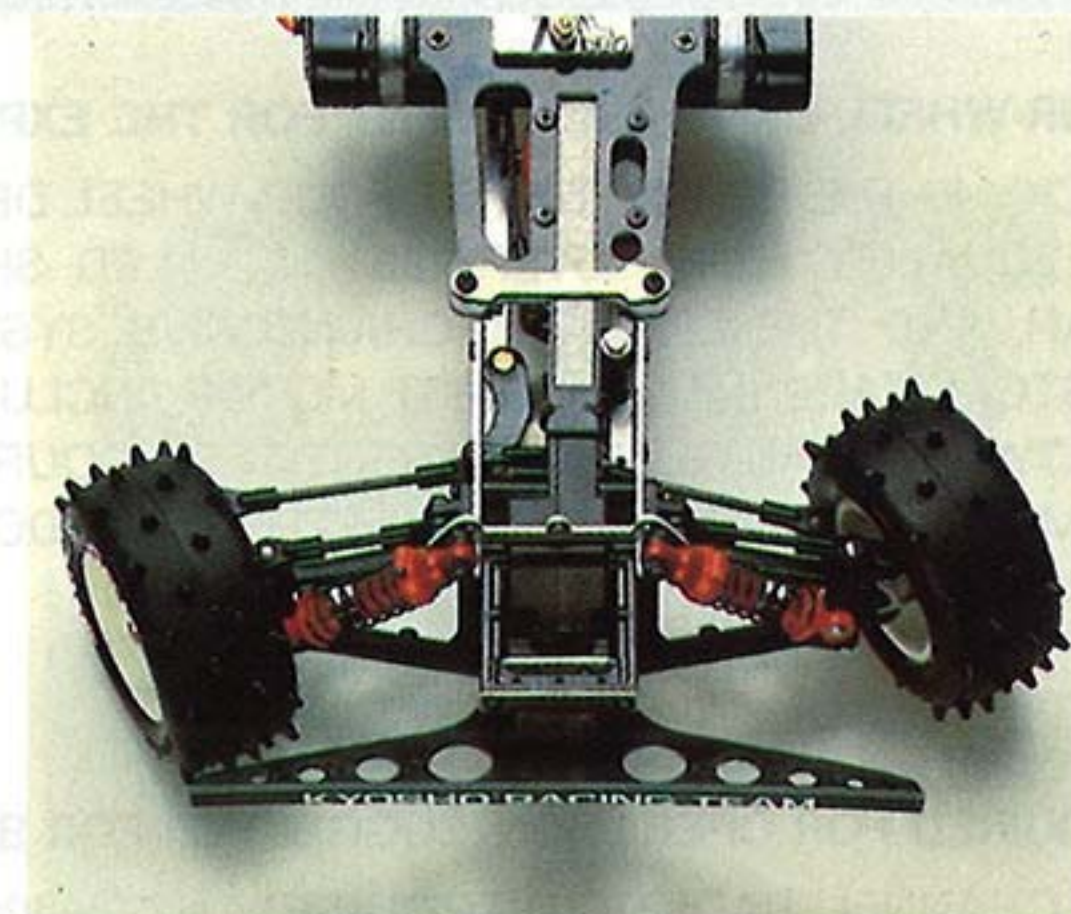

PRECISION ACKERMAN STEERING SYSTEM.

SYSTÈME DE DIRECTION DE PRÉCISION TYPE ACKERMANN.





#### FOUR-WHEEL DRIVE EXCITEMENT FOR THE EXPERT AND THE NEWCOMER!

ROCKY IS THE PERFECT FIRST FOUR-WHEEL DRIVE BUGGY. THE PRICE IS MODERATE AND THE QUALITY HIGH. OVERSIZE OIL-FILLED SHOCK ABSORBERS ARE USED FRONT AND REAR, AND THE EFFICIENT CHAIN DRIVE SYSTEM TRANSFERS FULL POWER FROM THE CUSTOM MADE LeMANS 240ST MOTOR (INCLUDED) TO THE FOUR BLOCK-PATTERN TIRES VIA TWIN METAL-GEAR DIFFERENTIALS. FOUR BALL BEARINGS CUT FRICTION TO A MINIMUM. (FULL SET OPTIONAL.) EXTR ALONG DOUBLE WISHBONE SUSPENSION FRONT/REAR ASSURES TOP STABILITY.

#### REQUIRED FOR OPERATION/SUGGESTED FOR BEST APPEARANCE

● 2-CHANNEL RADIO CONTROL SET ● 7.2V-1200mAh NiCd RACING BATTERY ● BATTERY CHARGER ● POLYCA COLOR PAINTS ● MICRONLINE STRIPPING TAPE

#### Technical Data

① Length/400mm(15.7in) ② Width/240mm(9.4in) ③ Height/120mm(4.7in) ④ Wheelbase/270mm(10.6in) ⑤ Ground Clearance/35mm(1.4in) ⑥ Front Track/200mm(7.9in) ⑦ Rear Track/190mm(7.5in) ⑧ Tires/(F)85φ×35mm(3.4×1.4in);(R)85φ×35mm(3.4×1.4in) ⑨ Total Weight/1600g(56.5oz) ⑩ Gear Ratio/9.59:1,10.79:1 ⑪ Motor/Le Mans 240ST(Included) ⑫ Battery/7.2V-1200mAh(Not included) ⑬ Radio/2-Channel(Not included)

#### Technische Daten

① Longueur ② Largeur ③ Hauteur ④ Empattement ⑤ Garde au sol ⑥ Voie Avant ⑦ Voie Arrière ⑧ Roue ⑨ Poids Total ⑩ Proportion Dembrayage ⑪ Moteur ⑫ Nicad

#### LE PLAISIR DES 4 ROUES MOTRICES POUR L'EXPERT COMME POUR LE DÉBUTANT!

ROCKY EST LE PREMIER BUGGY 4 ROUES MOTRICES IDÉAL, CAR IL PROCURE UN RAPPORT PRIX/QUALITÉ IMBATTABLE. DES AMORTISSEURS HYDRAULIQUES SURDIMENSIONNÉS À L'AVANT COMME À L'ARRIÈRE, ET LA PUISSANCE DU MOTEUR LeMANS 240ST EST TRANSMISE INTÉGRALEMENT AUX ROUES GRÂCE À L'UTILISATION D'UNE CHAÎNE ET DE DEUX DIFFÉRENTIELS À ENGRENAGES. APPLICATION DE 4 ROULEMENTS À BILLES (ÉQUIPEMENT INTÉGRAL EN OPTION). STABILITÉ ASSURÉE PAR LES BRAS DE SUSPENSION EXTRA LONGS.

#### ACCESSOIRES REQUIS ET DÉCORATION SUGGÉRÉE

• ENSEMBLE RADIO 2 VOIES • BATTERIE NiCad 7,2V-1200mAh • CHARGEUR • PEINTURES POLYCA •



# OFF-ROAD RACER "ROCKY 4WD,"

## ELECTRIC POWERED RACING BUGGY

1:10 SCALE  
NO.3101 • 15800



- 1] NEW LOW-PROFILE BLOCK-PATTERN TIRES FOR GOOD TRACTION.
- 2] CHAIN DRIVE FOR LOW POWER LOSS.
- 3] PROTECTIVE COVER ON SPEED CONTROLLER RESISTOR TO PREVENT BURNS.
- 4] FRONT/REAR POWER BIAS CAN BE CHANGED BY CHANGING SPROCKET.
- 5] MULTI-MOUNTING PLATE PERMITS VARIOUS SHOCK ABSORBER POSITIONS.
- 6] ALL SHOCKS ARE OVERSIZE DESIGN FOR MAXIMUM EFFECTIVENESS.
- 7] NEW BUMPER DESIGN "SKIDS" CAR OVER MOST OBSTRUCTIONS.
- 8] DOUBLE-WISHBONE FRONT SUSPENSION WITH LONG ARMS/TRAVEL.
- 9] RUNNING GEAR EASILY MOUNTED AND REMOVED FOR SERVICING.
- 10] THREE-SPEED CONTROLLER HAS SILVER CONTACTS FOR LONG LIFE.
- 11] SUPER-HIGH PERFORMANCE CUSTOM MADE LeMANS 240ST MOTOR.
- 12] DOUBLE-WISHBONE REAR SUSPENSION WITH LONG ARMS/TRAVEL.

1. NOUVEAUX PNEUS PROFIL BAS EN VUE D'UNE TRACTION OPTIMALE.
2. TRANSMISSION PAR CHAÎNE.
3. PROTECTION DE CHALEUR SUR LA RÉSISTANCE DU VARIATEUR.
4. RAPPORT DE TRACTION AV/AR VARIABLE PAR CHANGEMENT DE PIGNON.
5. POSSIBILITÉ DE MODIFIER LA POSITION DES AMORTISSEURS.
6. AMORTISSEURS SURDIMENSIONNÉS EN VUE D'UNE EFFICACITÉ MAXIMALE.
7. PARE-CHOC SPÉCIAL QUI SOULÈVE LA VOITURE PAR DESSUS LES OBSTACLES.
8. SUSPENSION AV À DOUBLES TRIANGLES LONGUE COURSE.
9. PIGNON D'ENTRAÎNEMENT BIEN ACCESSIBLE EN VUE DE L'ENTRETIEN.
10. VARIATEUR À 3 POSITIONS ET CONTACTS ARGENTÉS.
11. MOTEUR DE HAUTE PERFORMANCE LeMANS 240ST.
12. SUSPENSION AR À DOUBLES TRIANGLES LONGUE COURSE.

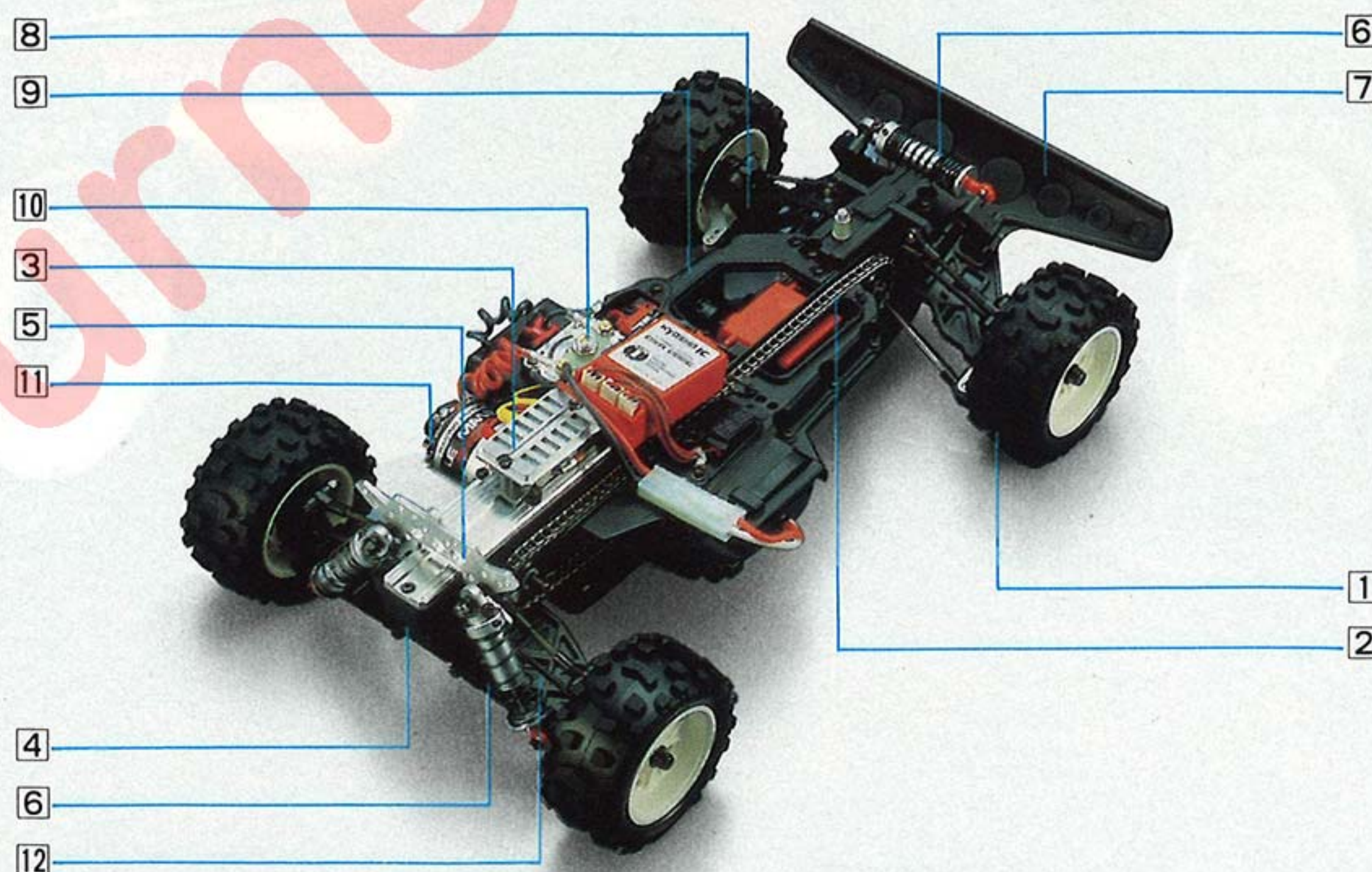

LIGHT, EFFECTIVE MONOSHOCK FRONT SUSPENSION. CAMBER ADJUSTABLE BY THREADED UPPER LINK.

SUSPENSION AV EFFICACE TYPE MONOSHOCK. CARROSSAGE RÉGLABLE PAR TIGE FILETÉE.

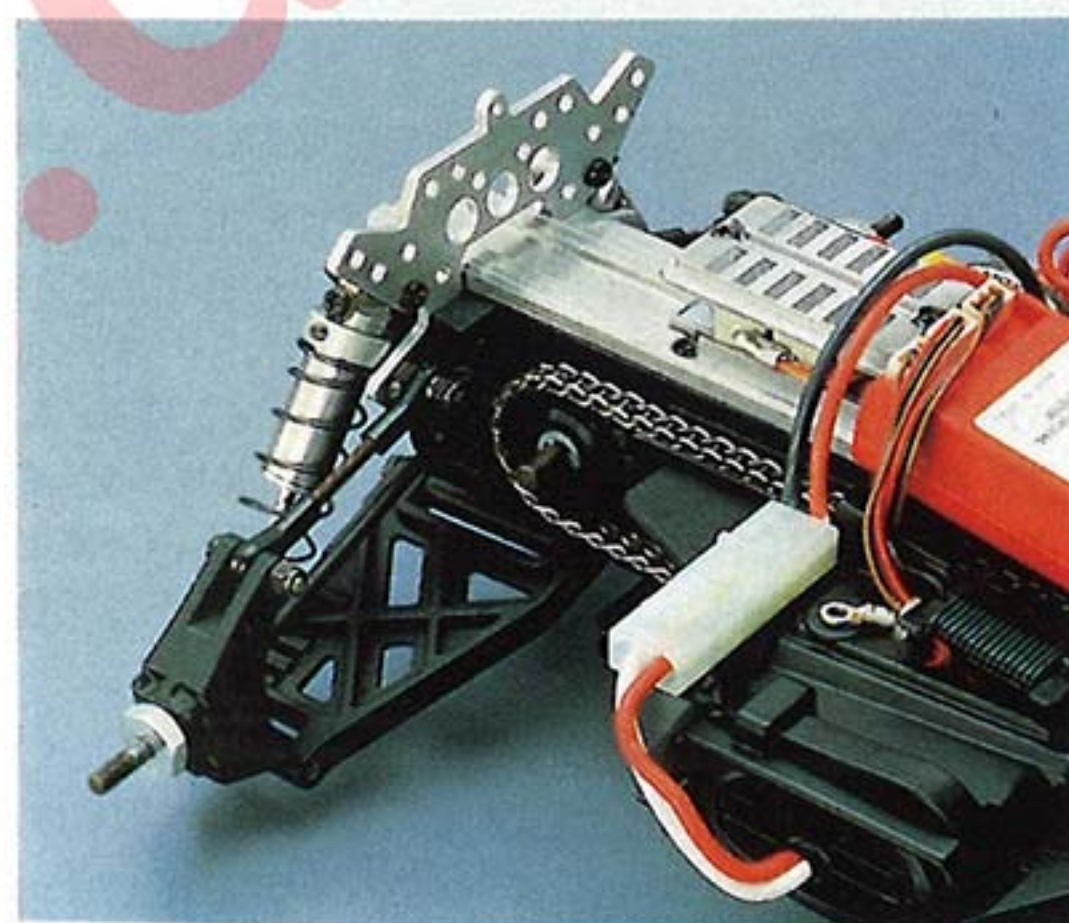

HANDLING CHARACTERISTICS CAN BE MODIFIED BY CHANGING REAR SHOCK POSITION.

COMPORTEMENT MODIFIABLE PAR PERMUTATION DES POINTS D'ATTACHE DES AMORTISSEURS.

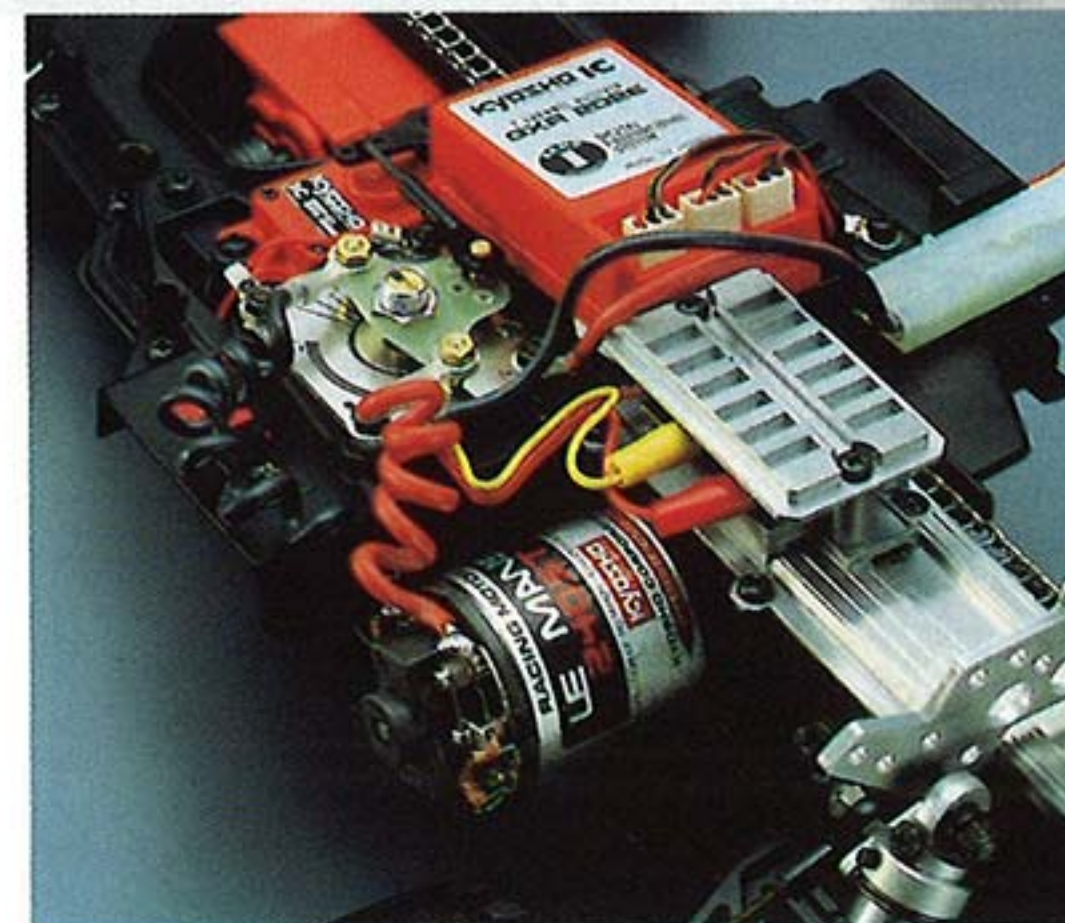

MIDSHIPS-MOUNTED LeMANS 240ST MOTOR IS CUSTOM MADE FOR HIGH-PERFORMANCE BUGGIES.

MOTEUR LeMANS 240ST CONÇU SPÉCIALEMENT POUR LES BUGGY DE PERFORMANCE, EN POSITION CENTRALE.

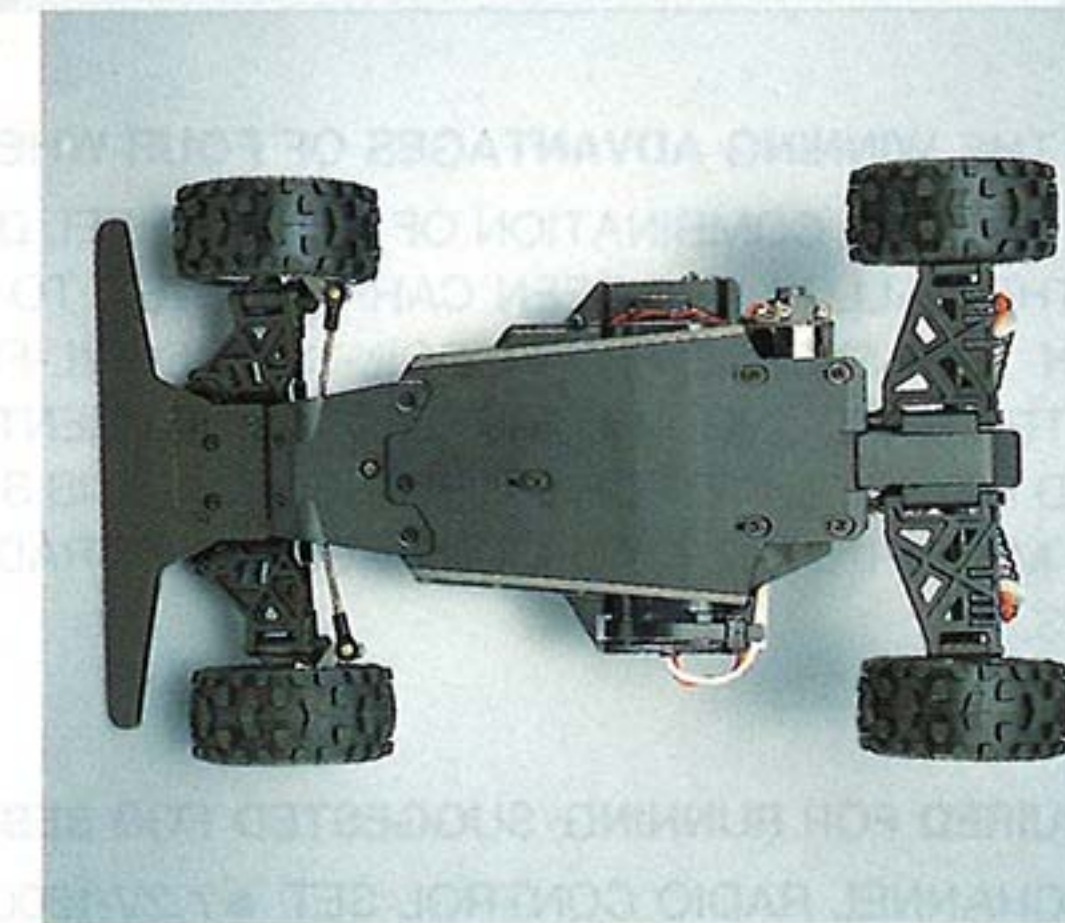

SMOOTH BELLYPAN SLIDES OVER OBSTRUCTIONS WITHOUT DAMAGE.

PROTECTION VENTRALE FAISANT GLISSER LA VOITURE PAR DESSUS LES OBSTACLES, EMPÊCHANT TOUT DOMMAGE À LA MÉCANIQUE.





#### ALL THE WINNING ADVANTAGES OF FOUR-WHEEL STEERING/DRIVE.

THE WINNING COMBINATION OF FOUR-WHEEL DRIVE/STEERING/INDEPENDENT SUSPENSION OF THE GALLOP HAS BEEN CARRIED OVER TO THE GALLOP MK II WITH THE ADDITION OF TWIN TRANSVERSE FRONT COIL-SPRING/OIL-FILLED SHOCK ABSORBER UNITS FOR EVEN BETTER HANDLING AND SIMPLER ADJUSTMENT, SUPER-RUGGED BALL JOINTS, STRENGTHENED RADIO PLATE FOR INCREASED CHASSIS STIFFNESS, AND A REAR GUARD TO PROTECT THE MOTOR. THE MK II CONTINUES THE TRADITION OF EASY HANDLING EVEN FOR BEGINNERS.

#### REQUIRED FOR RUNNING/SUGGESTED FOR BEST APPEARANCE

● 2-CHANNEL RADIO CONTROL SET ● 7.2V-1200mAh NiCd RACING BATTERY ● CHARGER ● POLYCA COLOR PAINT

#### Technical Data

① Length/410mm(16.1in) ② Width/235mm(9.25in) ③ Height/170mm(6.7in) ④ Wheelbase/272mm(10.7in) ⑤ Ground Clearance/27mm(1.1in) ⑥ Front Track/175mm(6.9in) ⑦ Rear Track/195mm(7.7in) ⑧ Tires/(F)85φ×32mm(3.3×1.3in);(R)85φ×40mm(3.3×1.6in) ⑨ Total Weight/1710g(60oz) ⑩ Gear Ratio/8.21:1,9.47:1 ⑪ Motor/RS-540S(Included) ⑫ Battery/7.2V-1200mAh(Not included) ⑬ Radio/2-Channel(Not included)

#### Technische Daten

① Longueur ② Largeur ③ Hauteur ④ Empattement ⑤ Garde au sol ⑥ Voie Avant ⑦ Voie Arrière ⑧ Roue ⑨ Poids Total ⑩ Proportion Dembrayage ⑪ Moteur ⑫ Nicad

#### TOUS LES AVANTAGES DE 4 ROUES MOTRICES ET DIRECTRICES.

LA COMBINAISON DE QUATRE ROUES INDÉPENDANTES MOTRICES ET DIRECTRICES DE LA GALLOP EST REPRIS PAR LA GALLOP MK II AVEC EN PLUS UNE DOUBLE PAIRE D'AMORTISSEURS HYDRAULIQUES TRANSVERSAUX, LE COMPORTEMENT DU MODÈLE EST ENCORE AMÉLIORÉ ET LA MISE AU POINT D'AVANTAGE SIMPLIFIÉE. LA VOITURE EST POURVUE DE ROTULES RENFORCÉES, D'UNE PLAQUE RADIO QUI RIGIDIFIE LE CHÂSSIS, ET D'UN PARE-CHOC AR EN VUE DE PROTÉGER LE MOTEUR. LA MK II EST PLUS QUE JAMAIS UNE VOITURE DOCILE, MÊME POUR LES DÉBUTANTS.

#### ACCESSOIRES REQUIS ET DÉCORATION SUGGÉRÉE

• ENSEMBLE RADIO 2 VOIES • BATTERIE DE COMPÉTITION 7,2V-1200mAh • CHARGEUR • PEINTURES POLYCA • FILETS ADHÉSIFS MICRONLINE •



# 4WDS OFF-ROAD RACER "GALLOP MKII,"

## ELECTRIC POWERED RACING BUGGY

1:10 SCALE  
NO.3069 • 22800

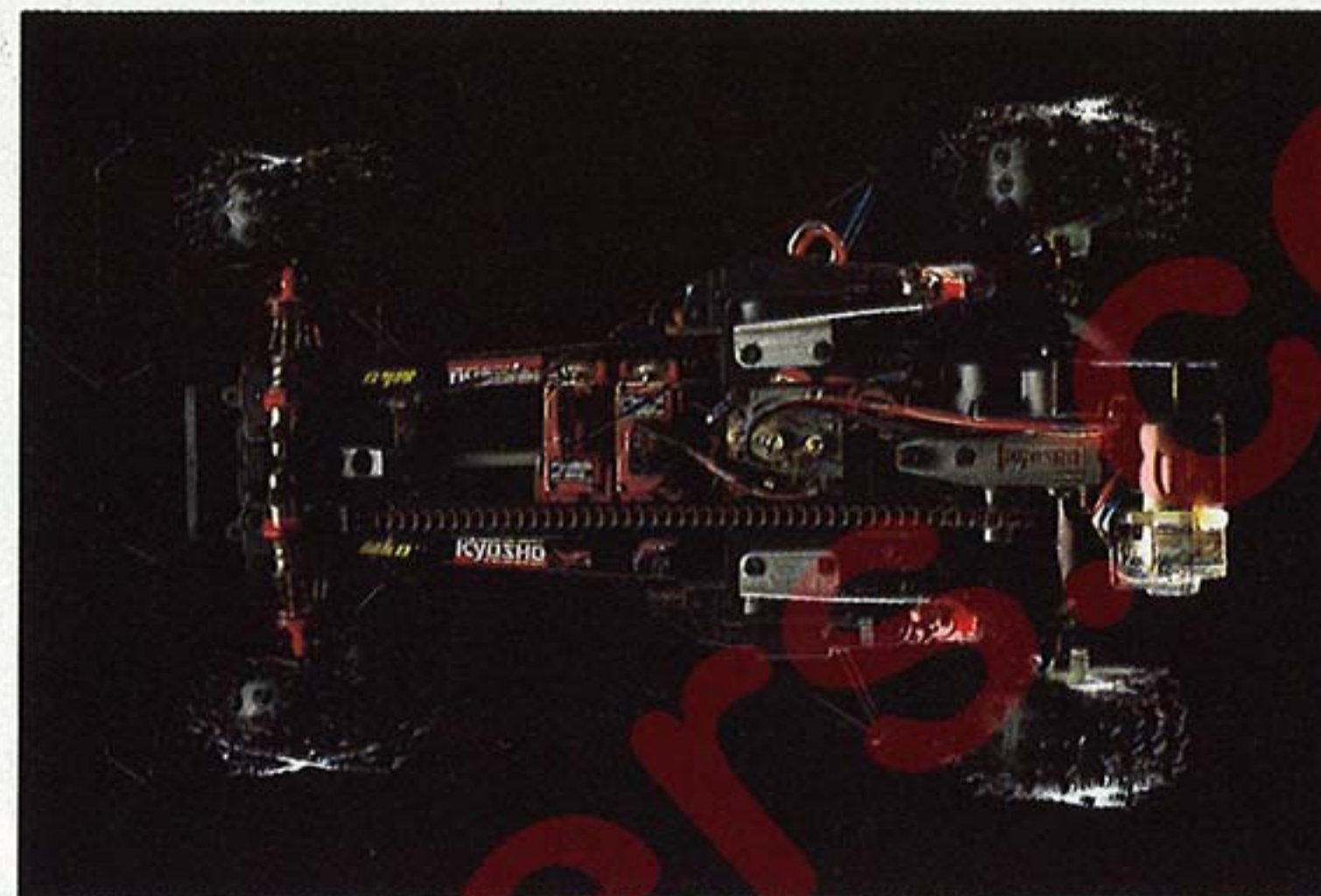
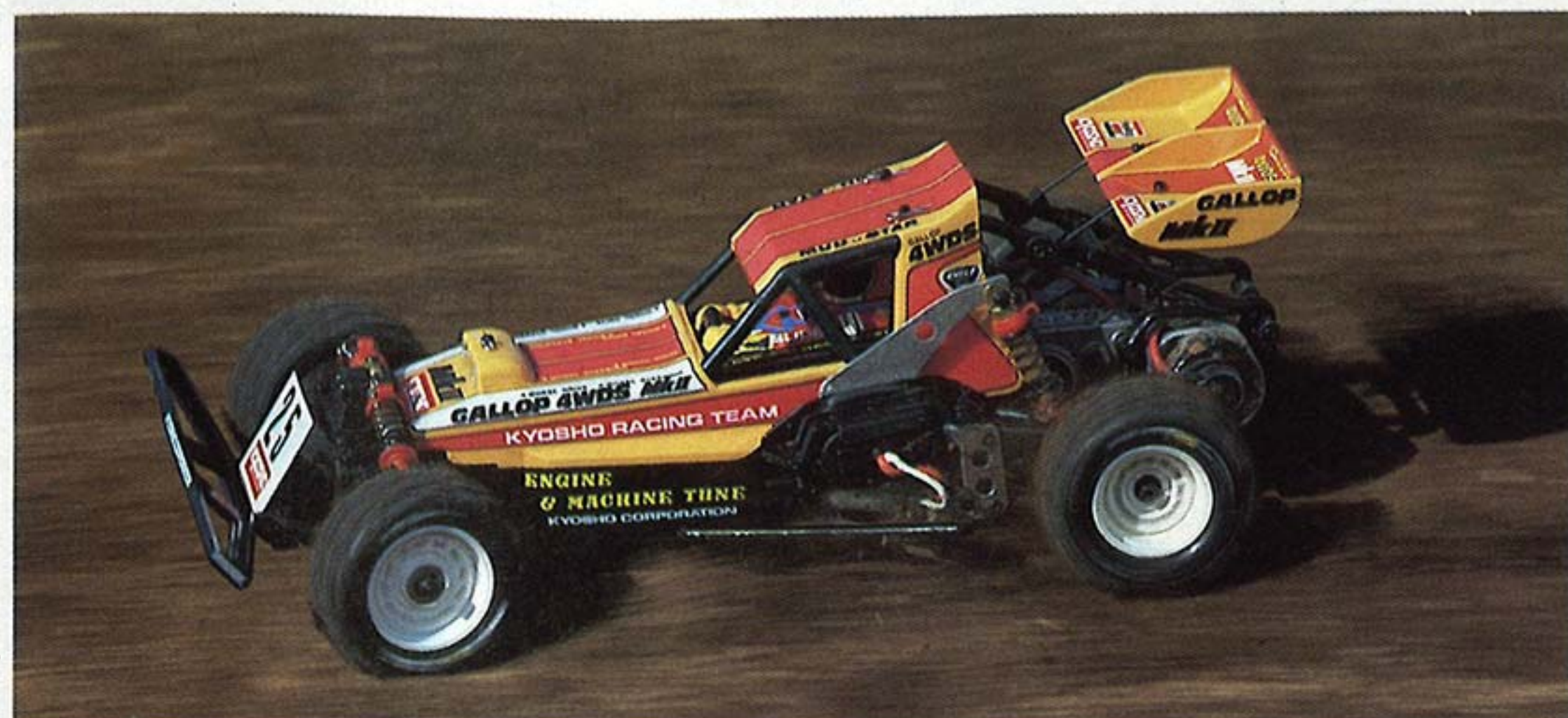

4WDS

- 1] GLASS-REINFORCED POLYESTER RADIO PLATE.
- 2] RELIABLE REINFORCED TIE-ROD.
- 3] TYPE 6 NYLON REAR GUARD.
- 4] TWIN TRANSVERSE COIL-SPRING/SHOCK ABSORBER UNITS (10mm DIA.).
- 5] HIGH-EFFICIENCY-TYPE LADDER DRIVE CHAIN.
- 6] GEARBOX/GEAR-TYPE DIFFERENTIAL.
- 7] DOUBLE-WISHBONE FRONT SUSPENSION.
- 8] DOUBLE-TRAILING ARM REAR SUSPENSION.

1. PLAQUE-RADIO EN POLYESTER/FIBRE DE VERRE.
2. ENSEMBLE RESSORT HÉLICOÏDAL.
3. PARE-CHOC AR EN NYLON.
4. DOUBLE RESSORT/AMORTISSEUR TRANSVERSAL DE 10mm.
5. CHAÎNE À HAUT RENDEMENT.
6. DIFFÉRENTIEL À ENGRENAGES.
7. SUSPENSION AV À BRAS PARALLÈLES.
8. SUSPENSION AR À BRAS PARALLÈLES.

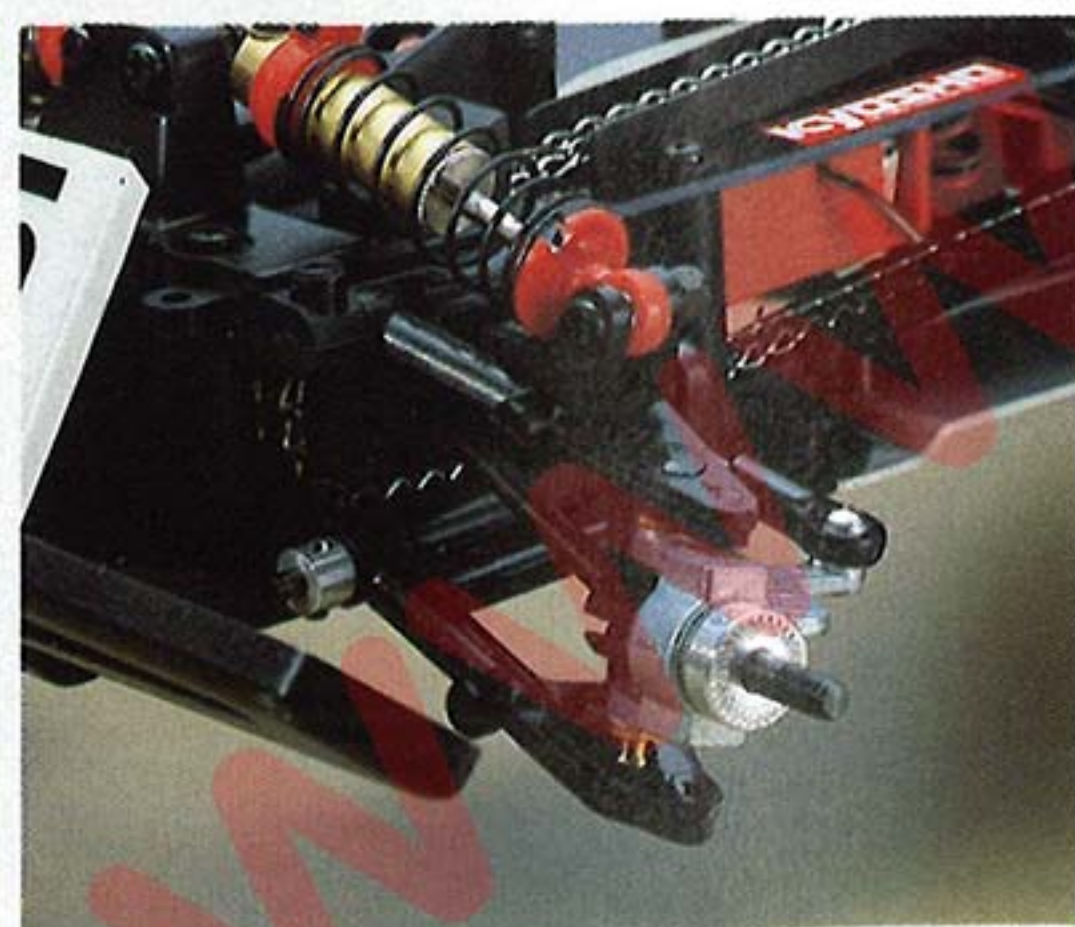
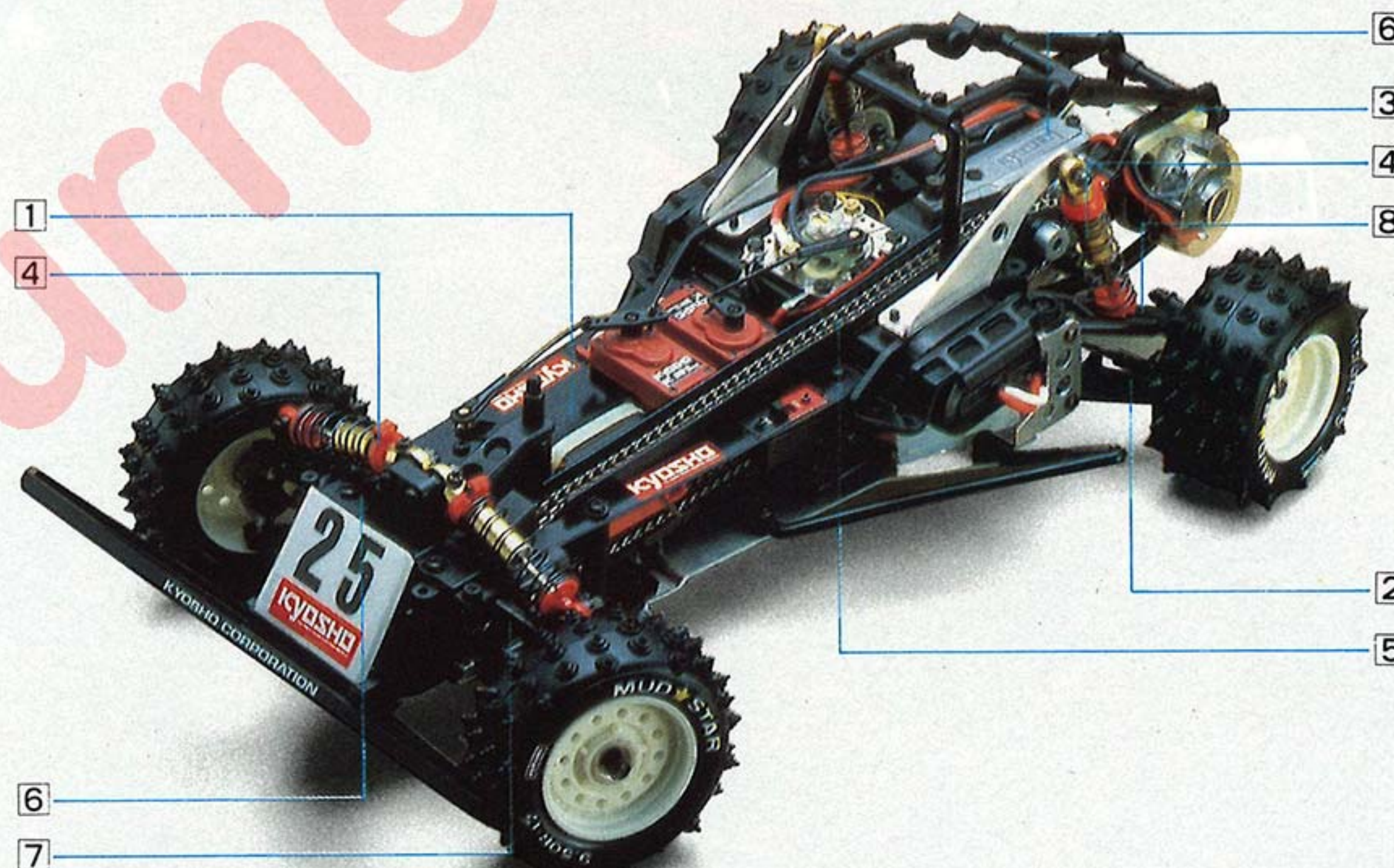

FRONT SUSPENSION FEATURES GLASS-REINFORCED DOUBLE WISHBONES, RUGGED BALL JOINTS.

SUSPENSION AV DOUBLES BRAS RENFORCÉS À LA FIBRE DE VERRE. ROTULES SURDIMENSIONNÉES.

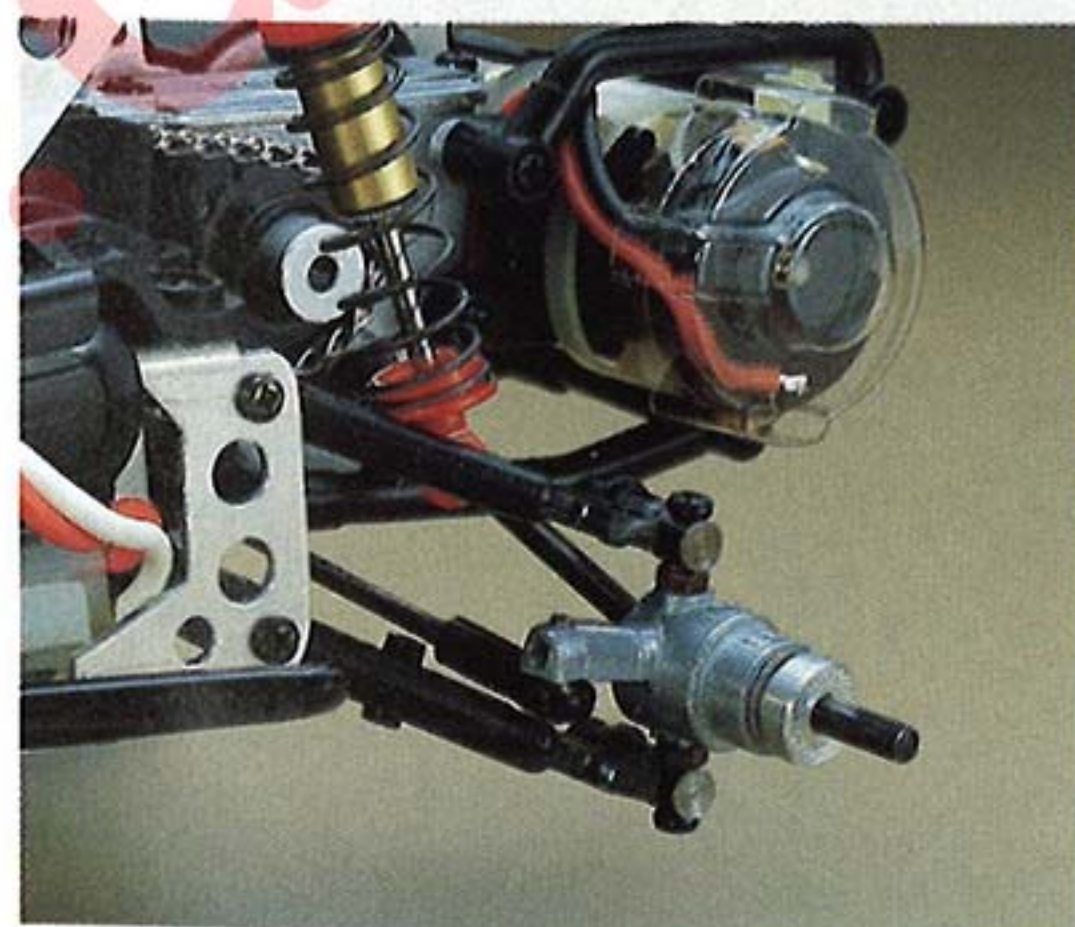

DOUBLE-WISHBONE REAR SUSPENSION ACTUALLY ALLOWS REAR WHEELS TO STEER FOR SHARPER TURNS.

SUSPENSION AR DOUBLES TRIANGLES. LES ROUES AR SONT ÉGALEMENT DIRECTRICES, PERMETTANT DES VIRAGES ENCORE PLUS SERRÉS.



GLASS-REINFORCED RADIO/SERVOMOTOR PLATE FOR CONVENIENCE AND STRENGTH; RELIABLE CHAIN DRIVE.

PLAQUE-RADIO RENFORCÉE À LA FIBRE DE VERRE, SOLIDE ET PRATIQUE. TRANSMISSION FIABLE PAR CHAÎNE.







# 4WD OFF-ROAD RACER "TURBO ROCKY," ELECTRIC POWERED SPECIAL RACING BUGGY

1:10 SCALE  
NO.3103 • 19800



## FOUR-WHEEL DRIVE EXCITEMENT FOR THE EXPERT AND THE NEWCOMER!

- ① NEW LOW-PROFILE BLOCK PATTERN TIRES FOR GOOD TRACTION.
- ② OVERSIZE, ADJUSTABLE, OIL-FILLED SHOCK ABSORBERS.
- ③ GEAR-TYPE DIFFERENTIAL FRONT/REAR.
- ④ FOUR WHEEL DRIVE BY LIGHT, EFFICIENT CHAIN.
- ⑤ 17S RADIO PLATE.
- ⑥ EXTRA-LONG WISHBONE/PARALLEL ARM SUSPENSION FRONT/REAR FOR STABILITY AT SPEED.
- ⑦ BUMPER GUIDES ROCKY OVER MOST OBSTACLES.
- ⑧ ANTI-ROLL BAR FRONT/REAR.
- ⑨ STRONG, LIGHT 17S ALUMINUM ALLOY CHASSIS.
- ⑩ HEAVY-DUTY WIRING FOR 8.4V.
- ⑪ SPEED CONTROLLER: 3 FORWARD, 1 REVERSE.
- ⑫ COMBINED UNIVERSAL JOINT/HALF-SHAFT.

## L'EXCITATION DE 4 ROUES MOTRICES POUR L'EXPERT COMME POUR LE DÉBUTANT!

1. NOUVEAUX PNEUS AV POUR UNE MEILLEURE TRACTION.
2. AMORTISSEURS HYDRAULIQUES RÉGLABLES SURDIMENSIONNÉS.
3. DIFFÉRENTIELS AV ET AR À ENGRENAGES.
4. QUATRE ROUES MOTRICES AVEC CHAÎNE DE TRANSMISSION.
5. PLAQUE RADIO EN 17S.
6. SUSPENSION AV ET AR PAR BRAS PARALLÈLES EXTRA LONGS POUR UNE BONNE STABILITÉ À GRANDE VITESSE.
7. PARE-CHOC AIDANT À FRANCHIR LES OBSTACLES.
8. BARRES STABILISATRICES AV ET AR.
9. CHÂSSIS RÉSISTANT EN ALUMINIUM 17S LÉGER.
10. CABLAGE RENFORCÉ POUR 8,4V.
11. VARIATEUR À 3 POSITIONS AV ET MARCHÉ AR.
12. JEUX DE CARDANS HOMOCINÉTIQUE.

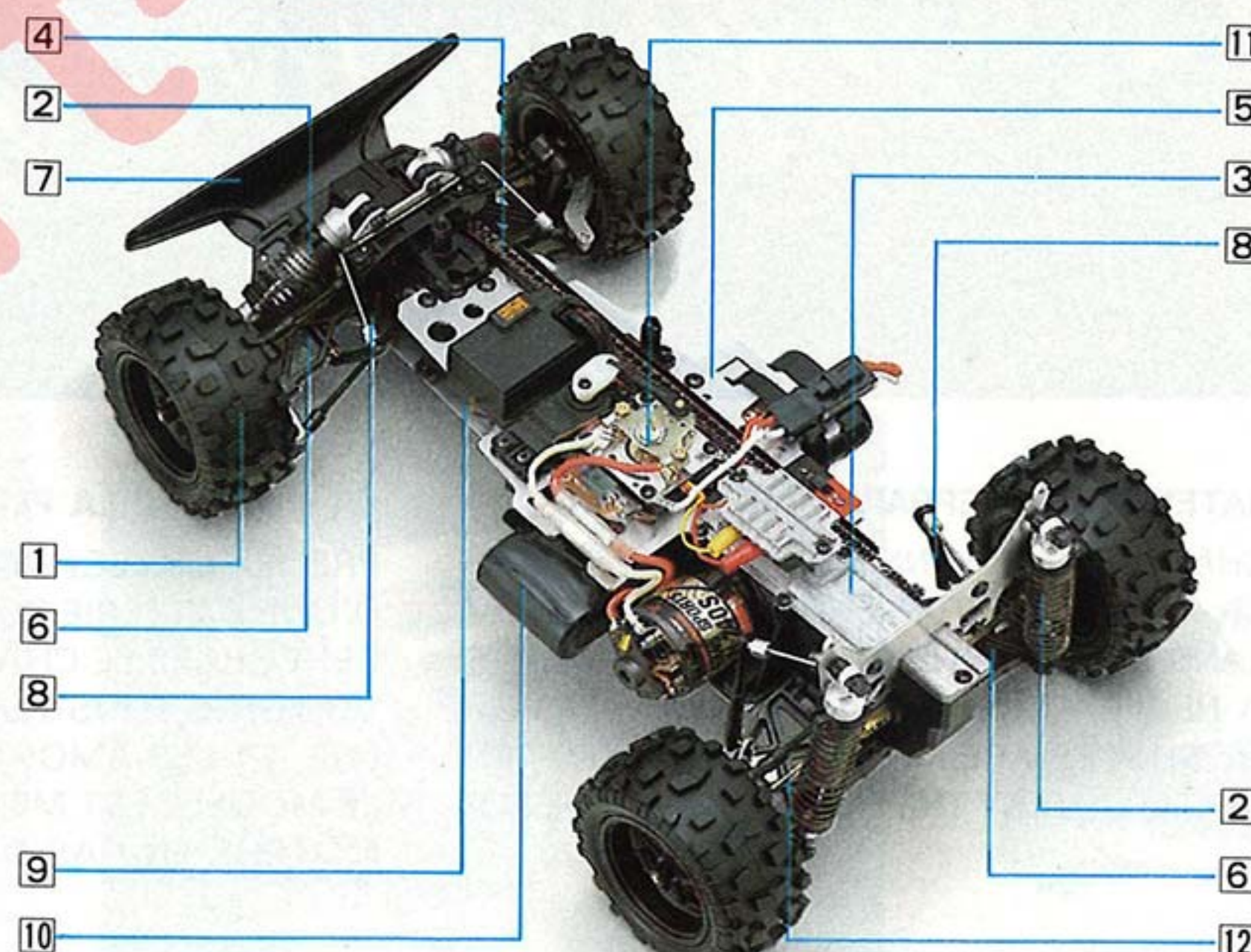

### REQUIRED FOR RUNNING/SUGGESTED FOR BEST APPEARANCE

- RADIO CONTROL SET (2-CHANNEL) ● MOTOR ● BATTERY (8.4V-1200mAh NiCd) ● BATTERY CHARGER ● POLYCA COLOR PAINT ● MICRONLINE STRIPING TAPE

### Technical Data

① Length/380mm(14.9in) ② Width/240mm(9.4in) ③ Height/120mm(4.7in) ④ Wheelbase/265mm(10.4in) ⑤ Ground Clearance/30mm(1.2in) ⑥ Front Track/200mm(7.9in) ⑦ Rear Track/190mm(7.5in) ⑧ Tires/(F)85φ×35mm(3.4×1.4in);(R)85φ×35mm(3.4×1.4in) ⑨ Total Weight/1600g(56.5oz) ⑩ Gear Ratio/8.93:1,12.59:1 ⑪ Motor/Le Mans 240/360Type(Not included) ⑫ Battery/8.4V-1200mAh(Not included) ⑬ Radio/2-Channel(Not included)

### Technische Daten

① Longueur ② Largeur ③ Hauteur ④ Empattement ⑤ Garde au sol ⑥ Voie Avant ⑦ Voie Arrière ⑧ Roue ⑨ Poids Total ⑩ Proportion Dembrayage ⑪ Moteur ⑫ Nicad

### ACCESSOIRES REQUIS ET DÉCORATION SUGGÉRÉE

- ENSEMBLE RADIO 2 VOIES ● MOTEUR (TYPE 540 OU 550) ● BATTERIE 8,4V-1200mAh ● CHARGEUR ● PEINTURES POLYCA ● RUBANS ADHÉSIFS MICRONLINE ●





#### THE QUICKEST WAY BETWEEN TWO POINTS WHATEVER THE TERRAIN!

TAKE ALL THE ADVANCED FEATURES OF THE CHAMPIONSHIP-WINNING OPTIMA, ADD THE SUPER POWER OF AN 8.4V NiCd BATTERY PACK AND A SUPER-PERFORMANCE CUSTOM MADE LeMANS 240S MOTOR (INCLUDED IN KIT), AND BEEF UP THE CHASSIS COMPONENTS TO TAKE THE HIGHER SPEED, AND YOU HAVE A NEW EXPERIENCE IN OFF-ROAD RACING! STABILIZER BARS ARE A NEW FEATURE, AND THE SHOCKS ARE KYOSHO'S BEST "OPTIPN HOUSE" TYPE. THERE'S EVEN A TORQUE LIMITER TO PROTECT THE MOTOR IF THE WHEELS BECOME JAMMED.

#### REQUIRED FOR OPERATION/ < > : SALUTE

● 2-CHANNEL RADIO CONTROL SET ● 8.4V-1200mAh NiCd BATTERY PACK ● CHARGER ● POLYCA COLOR PAINT < ● MOTOR >

#### Technical Data/< >: SALUTE

① Length/390mm(15.4in) ② Width/240mm(9.4in) ③ Height/125mm(4.9in) ④ Wheelbase/260mm(10.2in) ⑤ Ground Clearance/35mm(1.4in) ⑥ Front Track/200mm(7.9in) ⑦ Rear Track/202mm(8.0in) ⑧ Tires/(F)85φ×37mm(3.3×1.5in);(R)85φ×37mm(3.3×1.5in) ⑨ Total Weight/1700g(60oz) ⑩ Gear Ratio/13.8:1 ⑪ Motor/Le Mans 240S(Included)<Le Mans 240/360Type;Not included> ⑫ Battery/8.4V-1200mAh(Not included) ⑬ Radio/2-Channel(Not included)

#### Technische Daten

① 長さ ② 幅 ③ 高さ ④ 軸間 ⑤ 離地高 ⑥ 前軸間 ⑦ 後軸間 ⑧ タイヤ ⑨ 総重量 ⑩ 減速比 ⑪ モーター ⑫ ニカド

#### LA MANIÈRE LA PLUS RAPIDE DE FRANCHIR UNE DISTANCE!

PRENEZ LA TECHNOLOGIE AVANCÉE DE L'OPTIMA, AJOUTEZ-Y LA PUISSANCE ACCRUE D'UNE BATTERIE SUPER PERFORMANTE DE 8,4V ET DU MOTEUR LeMANS 240S (INCLUS), RENFORCEZ LE CHÂSSIS, ET VOUS VIVREZ UNE NOUVELLE EXPÉRIENCE EN MATIÈRE DE VOITURES TOUTS-TERRAINS. LES BARRES STABILISATRICES SONT UNE NOUVEAUTÉ ABSOLUE, ET LES AMORTISSEURS SONT LES MEILLEURS DU PROGRAMME 'OPTION HOUSE'. LE MODÈLE EST MÊME ÉQUIPÉ D'UN LIMITEUR DE COUPLE EN GUISE DE PROTECTION DU MOTEUR EN CAS DE BLOCAGE DES ROUES.

#### ACCESSOIRES REQUIS ET DÉCORATION SUGGÉRÉE/< > : SALUTE

● ENSEMBLE RADIO 2 VOIES ● BATTERIE 8,4V-1200mAh ● CHARGEUR ● PEINTURES POLYCA < ● MOTEUR >



## 4WD OFF-ROAD RACER "TURBO OPTIMA,"

ELECTRIC POWERED 4WD RACING BUGGY

NO.3130 • 29800

## 4WD OFF-ROAD RACER "SALUTE,"

ELECTRIC POWERED 4WD RACING BUGGY

NO.3034 • 25800

1:10 SCALE



- 1 STABILIZER BAR FOR IMPROVED HANDLING THROUGH THE CURVES.
- 2 OVERSIZE "OPTION HOUSE" SHOCK ABSORBERS FOR TOP HANDLING IN THE ROUGH.
- 3 NEW LOW-PROFILE KNOBBY TIRES.
- 4 NEW HEVY-DUTY SPEED CONTROLLER FOR 8.4V POWER.
- 5 COMBINED GEARBOX/FRONT REAR DIFFERENTIAL, FRONT DIFFERENTIAL.
- 6 LIGHTWEIGHT, STRONG NYLON WHEELS.
- 7 NEW HEAVY-DUTY FRONT WISHBONES; EXTRA STRENGTH FOR HIGHER SPEEDS.
- 8 HARDENED-STEEL CHAIN SHIELDED TO MINIMIZE WEAR.
- 9 POWERFUL 8.4V NICD BATTERY MOUNTED CROSSWISE FOR PERFECT BALANCE.
- 10 OVERSIZE "OPTION HOUSE" REAR SHOCK ABSORBERS.
- 11 HEAVY-DUTY REAR WISHBONES AND STABILIZER BAR.
- 12 SUPER-PERFORMANCE LeMANS 240S CUSTOM MOTOR (INCLUDED).

1. BARRE STABILISATRICE AMÉLIORANT LE COMPORTEMENT DANS LES VIRAGES.
2. AMORTISSEURS 'OPTION HOUSE' HYPER EFFICACES SUR LES TERRAINS TRÈS ACCIDENTÉS.
3. NOUVEAUX PNEUS PROFILÉS.
4. NOUVEAU VARIATEUR À GRAND DÉBIT POUR 8,4V.
5. BOÎTIERS À ENGRENAGES/DIFFÉRENTIELS COMBINÉS À L'AVANT ET À L'ARRIÈRE.
6. JANTES SUPER LÉGÈRES EN NYLON.
7. NOUVEAUX BRAS DE SUSPENSION AV, RENFORCÉS EN VUE DE PLUS GRANDES VITESSES.
8. CHAÎNE EN ACIER TREMPÉ, CARÉNÉE EN VUE DE SA LONGÉVITÉ.
9. ACCU SUPER PUISSANT 8,4V, INSTALLÉ EN TRAVERS POUR UN PARFAIT ÉQUILIBRAGE DE LA VOITURE.
10. AMORTISSEURS 'OPTION HOUSE' HYPER EFFICACES.
11. SUSPENSION AR RENFORCÉE AVEC BARRE STABILISATRICE.
12. MOTEUR SÉLECTIONNÉ DE PERFORMANCE LeMANS 240S (INCLUS).

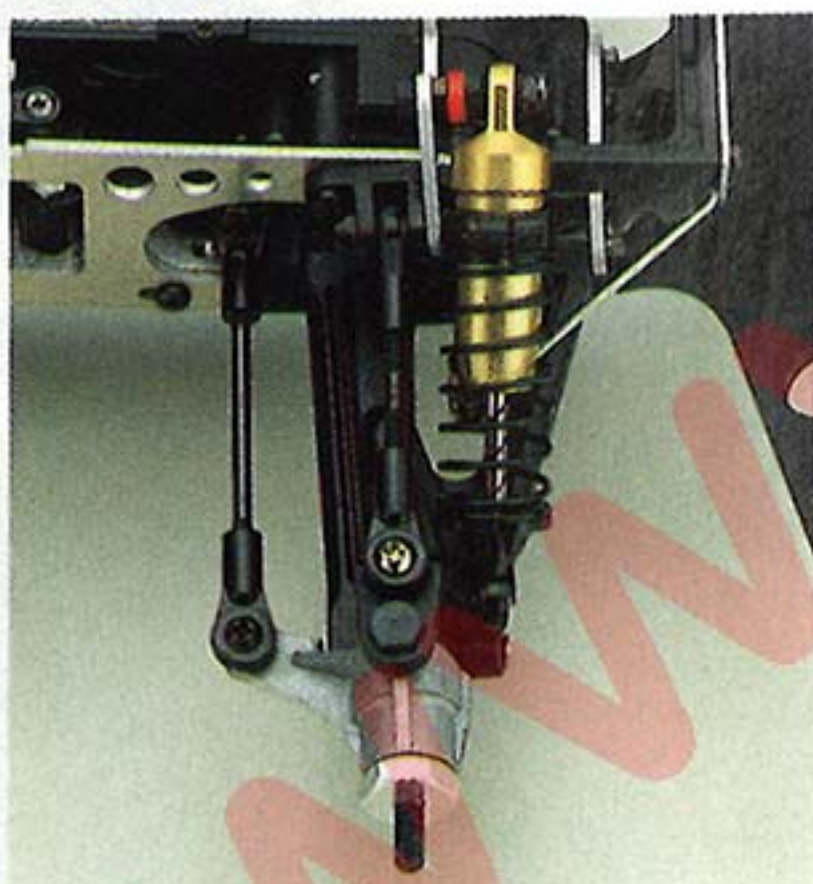
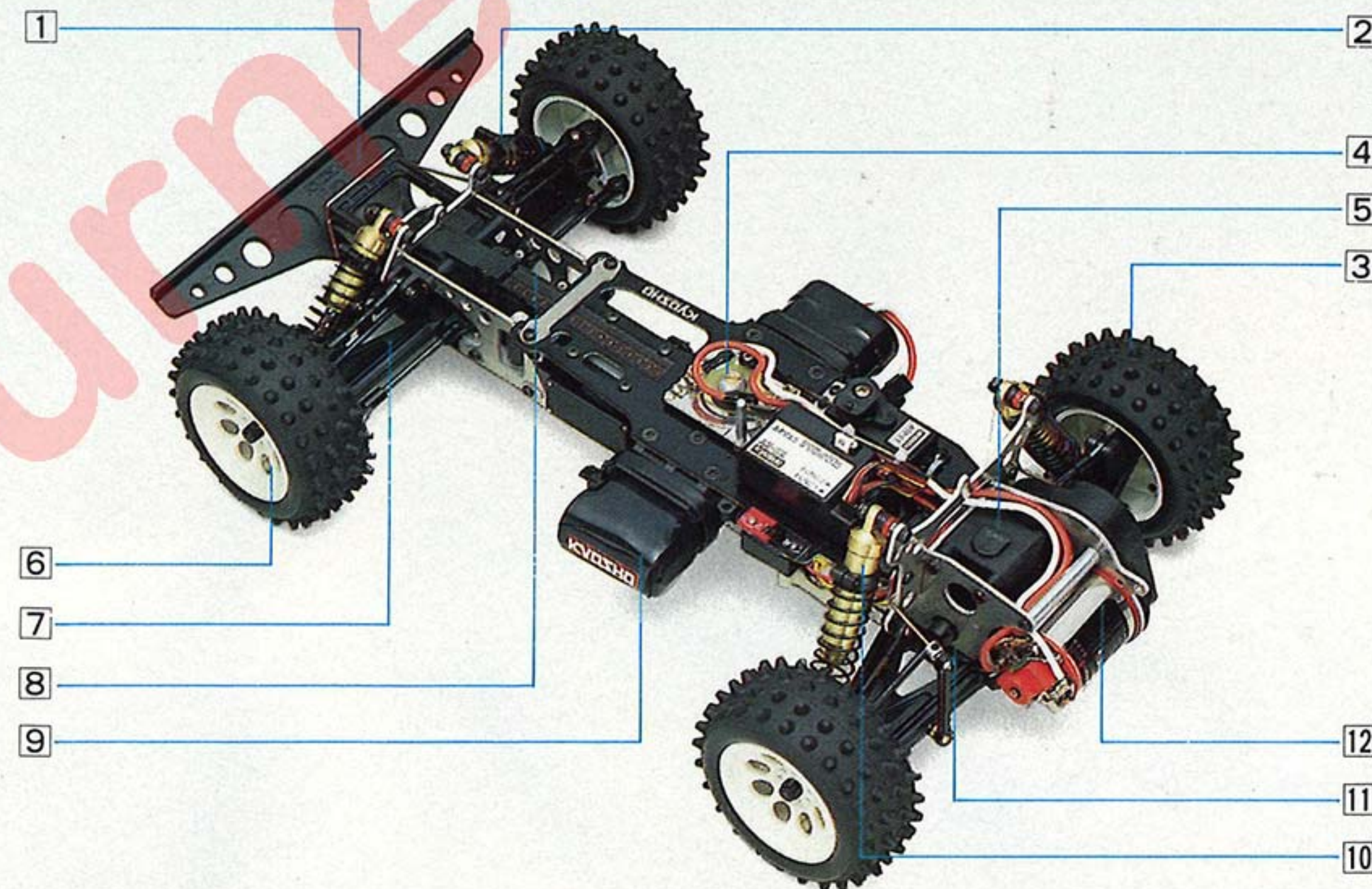

OVERSIZE, SUPER-EFFECTIVE SHOCK ABSORBERS FRONT AND REAR, WITH STABILIZER BARS FOR TOP HANDLING.

AMORTISSEURS AV ET AR SURDIMENSIONNÉS ET BARRES STABILISATRICES.



SUPER POWER LeMANS MOTOR IS CUSTOM MADE FOR HIGH PERFORMANCE VEHICLES.

MOTEUR LeMANS SURPUISSANT, SPÉCIALEMENT CONÇU POUR LES VOITURES DE HAUTE PERFORMANCE.

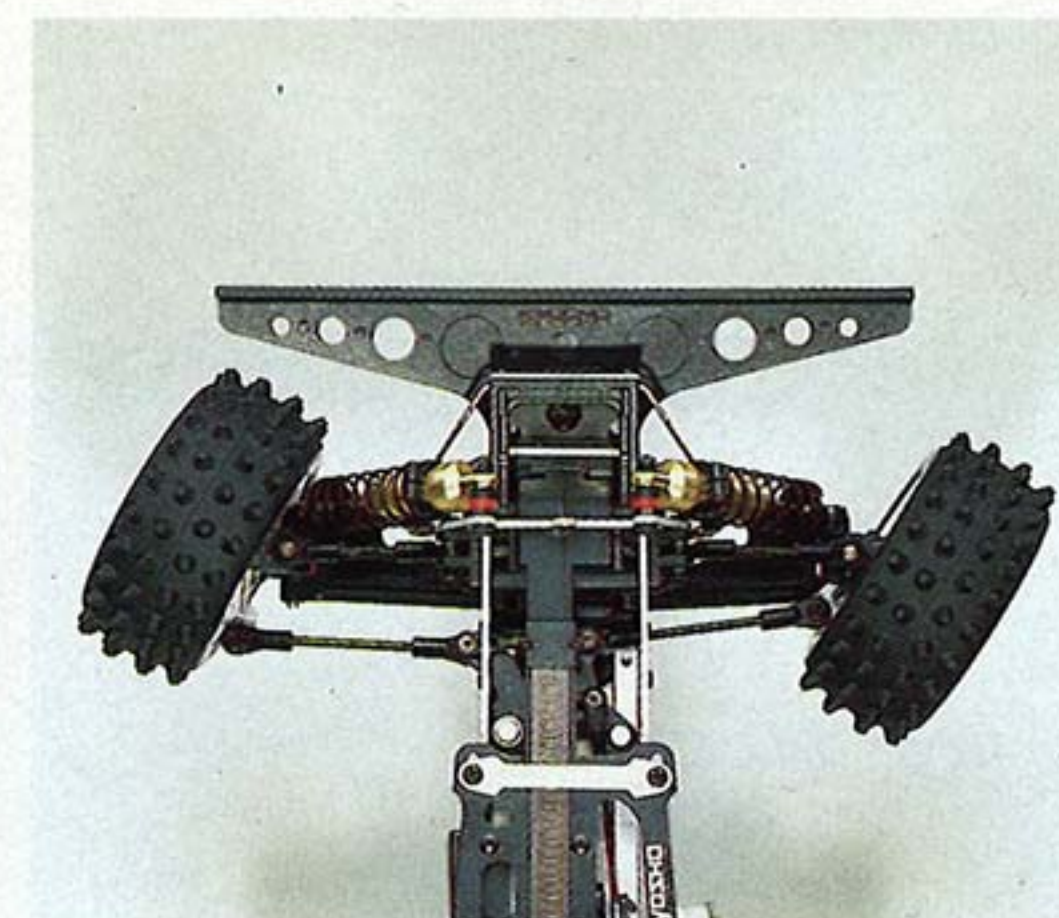

DUPLEX SERVO SAVERS PREVENT SERVO DAMAGE. LONG SUSPENSION ARMS ALLOW LONG BOUNCE TRAVEL.

DOUBLES SAUVE-SERVO. SUSPENSIONS À LONGUE COURSE POUR LES TERRAINS TRÈS ACCIDENTÉS.



# SPECIAL RACING CAR

■ HONDA CR-X ■ PEUGEOT 205 ■ PLAZMA MK III / KS-2  
■ PLAZMA MK III / LIMITED ■ FANTOM EXT / CRC-II  
■ FANTOM EXT / BW-SPIDER

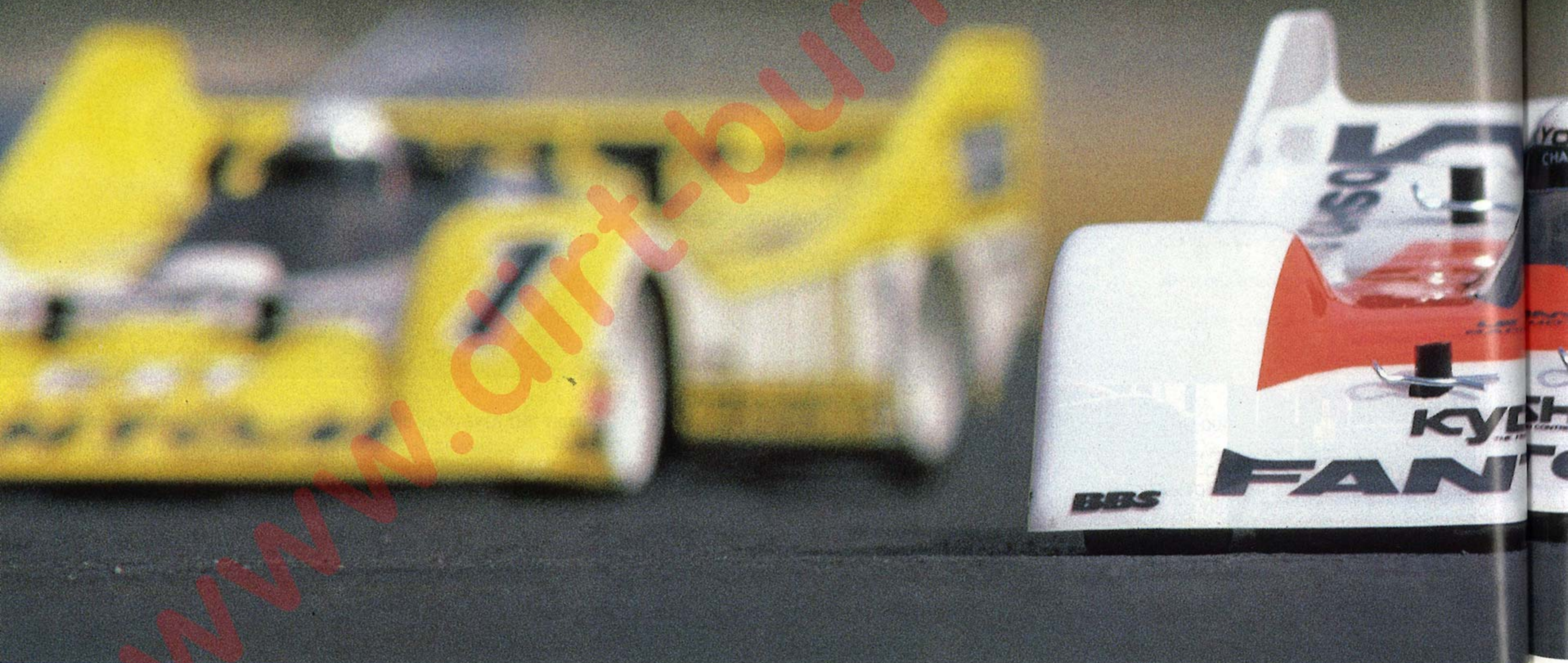



## ELECTRIC POWERED SPECIAL RACING CARS



		Length	Height	Weight	Suspension	Shock Absorber	Ball Bearing	Motor	Battery	Drive System	Option Parts
2 W D	HONDA CR-X	315mm	110mm	1100g	(F)WS (R)WS	4 Oil-Filled Shock Absorbers	(Not included)	LeMans STOCK 05	7.2V-1200mAh	—	△
	PEUGEOT 205	320mm	110mm	1100g	(F)WS (R)WS	//	(Not included)	LeMans 05	7.2V-1200mAh	—	△
	PLAZMA MKIII KS-2	350mm	80mm	880g	(F)SS (R)TS	Oil-Filled Shock Absorber	2pcs.	LeMans 600E	7.2V-1200mAh	—	◎
	PLAZMA MKIII LIMITED	350mm	80mm	880g	(F)SS (R)TS	//	8pcs.	LeMans 480 Type	7.2V-1200mAh	—	◎
4 W D	FANTOM EXT CRC-II	350mm	80mm	880g	(F)SS (R)TS	//	5pcs.	LeMans 480 Type	7.2V-1200mAh	Chain	◎
	FANTOM EXT BW-SPIDER	350mm	80mm	880g	(F)SS (R)TS	//	5pcs.	LeMans 480 Type	7.2V-1200mAh	Chain	◎

ABBREVIATIONS : POSSIBILITY OF HOP-UP <◎=HIGH, ○=MODERATE, △=LOW> (F)=FRONT, (R)=REAR, WS=DOUBLE WISHBONES SUSPENSION, TS= TRAILING ARM SUSPENSION SS=PILLAR-TYPE, INDEPENDENT SUSPENSION





#### RACY GOOD LOOKS AND LOST OF DRIVING FUN!

THIS BEAUTIFUL 1/12-SCALE MODEL FUNS AT REALISTIC SPEED AND HAS A FULLY FUNCTIONING INDEPENDENT SUSPENSION SYSTEM FRONT AND REAR, WITH DOUBLE WISH-BONES AND EFFECTIVE OIL-FILLED SHOCK ABSORBERS. THE POWERFUL Le MANS STOCK 05 MOTOR (INCLUDED) IS FRONT MOUNTED AND DRIVES THE FRONT WHEELS TO PULL THE MODEL THROUGH CORNERS. GEAR-TYPE DIFFERENTIAL. EASY ASSEMBLY. SIMPLE MAINTENANCE. MANY DECORATIVE STICKERS. TREAD-PATTERN TIRES. IDEAL FIRST CAR.

#### REQUIRED FOR OPERATION/SUGGESTED FOR BEST APPEARANCE

● 2-CHANNEL RADIO CONTROL SET ● 7.2V-1200mAh NiCd RACING BATTERY ● BATTERY CHARGER ● POLYCA COLOR PAINT ● MICRONLINE STRIPPING TAPE

#### Technical Data

① Length/315mm(12.4in) ② Width/165mm(6.5in) ③ Height/110mm(4.4in) ④ Wheelbase/190mm(7.5in) ⑤ Ground Clearance/5mm(0.2in) ⑥ Front Track/136mm(5.3in) ⑦ Rear Track/136mm(5.3in) ⑧ Tires/(F)58φ×27mm(2.3×1.1in);(R)58φ×27mm(2.3×1.1in) ⑨ Total Weight/1100g(38.7oz) ⑩ Gear Ratio/3.8:1 ⑪ Motor/Le Mans stock 05(Included) ⑫ Battery/7.2V-1200mAh(Not included) ⑬ Radio/2-Channel(Not included)

#### Technische Daten

① Longueur ② Largeur ③ Hauteur ④ Empattement ⑤ Garde au sol ⑥ Voie Avant ⑦ Voie Arrière ⑧ Roue ⑨ Poids Total ⑩ Proportion Dembrayage ⑪ Moteur ⑫ Nicad

#### PERFORMANCES DE COURSE ET UN PLAISIR À PILOTER!

CE MAGNIFIQUE MODÈLE À L'ÉCHELLE 1/12 ROULE À UNE VITESSE RÉALISTE ET DISPOSE D'UNE SUSPENSION INDÉPENDANTE DES 4 ROUES À DOUBLES BRAS ET AMORTISSEURS HYDRAULIQUES. LE MOTEUR LeMANS STOCK 05 EST INSTALLÉ À L'AVANT ET ENTRAÎNE LES ROUES AV, CE QUI FAVORISE LE COMPORTEMENT DE LA VOITURE DANS LES VIRAGES. DIFFÉRENTIEL À ENGRENAGES. FACILE À ASSEMBLER ET À ENTREtenir. LE KIT CONTIENT DE NOMBREUX MOTIFS DE DÉCORATION. PNEUS PROFILÉS. IDÉALE COMME PREMIÈRE VOITURE.

#### ACCESSOIRES REQUIS ET DÉCORATION SUGGÉRÉE

• ENSEMBLE RADIO 2 VOIES • BATTERIE 7,2V-1200mAh • CHARGEUR • PEINTURES POLYCA • FILETS ADHÉSIFS MICRONLINE •



**FF RACER "HONDA CR-X,"**  
ELECTRIC POWERED FF RACING CAR  
NO.3171 • 12000

**FF RACER "PEUGEOT 205,"**  
ELECTRIC POWERED FF RACING CAR  
NO.3172 • 12800

1:12 SCALE



- 1 STRONG NYLON BUMPER FOR CRASH PROTECTION.
- 2 DOUBLE-WISHBONE. INDEPENDENT SUSPENSION FRONT/REAR WITH OIL-FILLED SHOCK ABSORBERS.
- 3 ALUMINUM. SAFETY. CAGE AROUND RESISTORS.
- 4 STRONG, LIGHT 17S ALUMINUM CHASSIS.
- 5 ABS RADIO PLATE.
- 6 SEMI-PNEUMATIC TIRES WITH ROAD TREAD PATTERN.
- 7 STYLISH, STRONG, LIGHT ONE PIECE NYLON WHEELS.
- 8 POWERFUL LeMANS "STOCK 05" MOTOR (INCLUDED).
- 9 DIRECT-MOUNTED SERVO. SAVER FOR STEERING SERVO.
- 10 SPEEDO CONTROLLER. (3 FORWARD, 2 REVERSE).
- 11 SPEED. CONTROLLER. SERVO. (NOT INCLUDED).

1. PARE-CHOC DE PROTECTION EN NYLON.
2. SUSPENSION AV ET AR À DOUBLES BRAS ET AMORTISSEURS HYDRAULIQUES.
3. PROTECTION EN ALUMINIUM SUR LES RÉSISTANCES DU VARIATEUR.
4. CHÂSSIS RÉSISTANT EN ALUMINIUM 17S.
5. PLAQUE RADIO EN ABS.
6. PNEUS SEMI-PNEUMATIQUES À PROFIL DE ROUTE.
7. JANTES INTÉGRALES EN NYLON RÉSISTANT MAIS LÉGER.
8. MOTEUR PUISSANT LeMANS 'STOCK 05' (INCLUS).
9. SAUVE-SERVO INTÉGRAL POUR LA DIRECTION.
10. VARIATEUR À 3 POSITIONS AV ET 2 POSITIONS AR.
11. SERVO DES GAZ (NON COMPRIS).

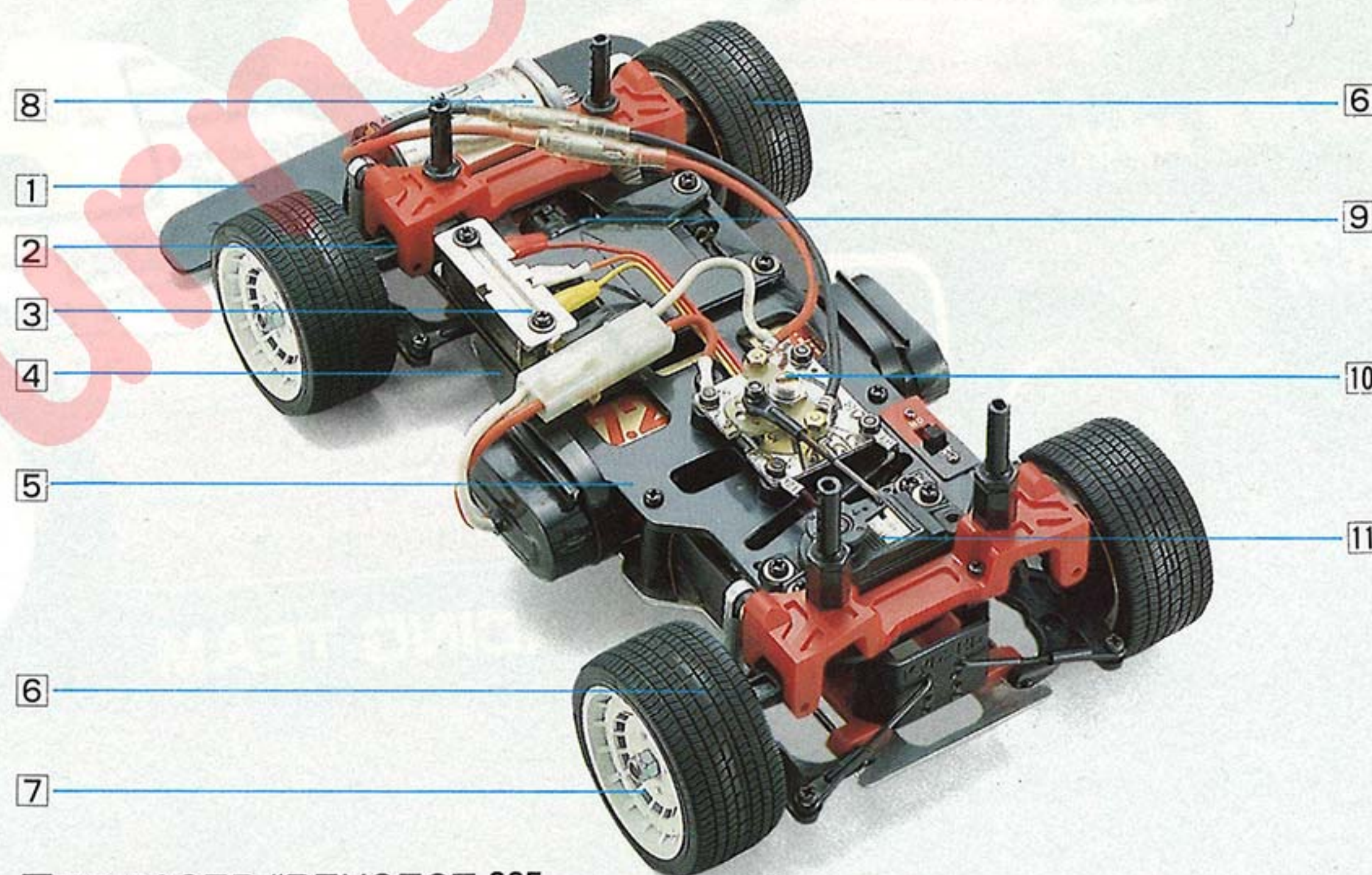

■ FF RACER "PEUGEOT 205,"



FRONT-WHEEL DRIVE FOR REALISTIC DRIVING PERFORMANCE. POWERFUL LeMANS "STOCK 05" MOTOR.

TRACTION AVANT POUR UN MEILLEUR RÉALISME DE CONDUITE. MOTEUR PUISSANT LeMANS 'STOCK 05'.

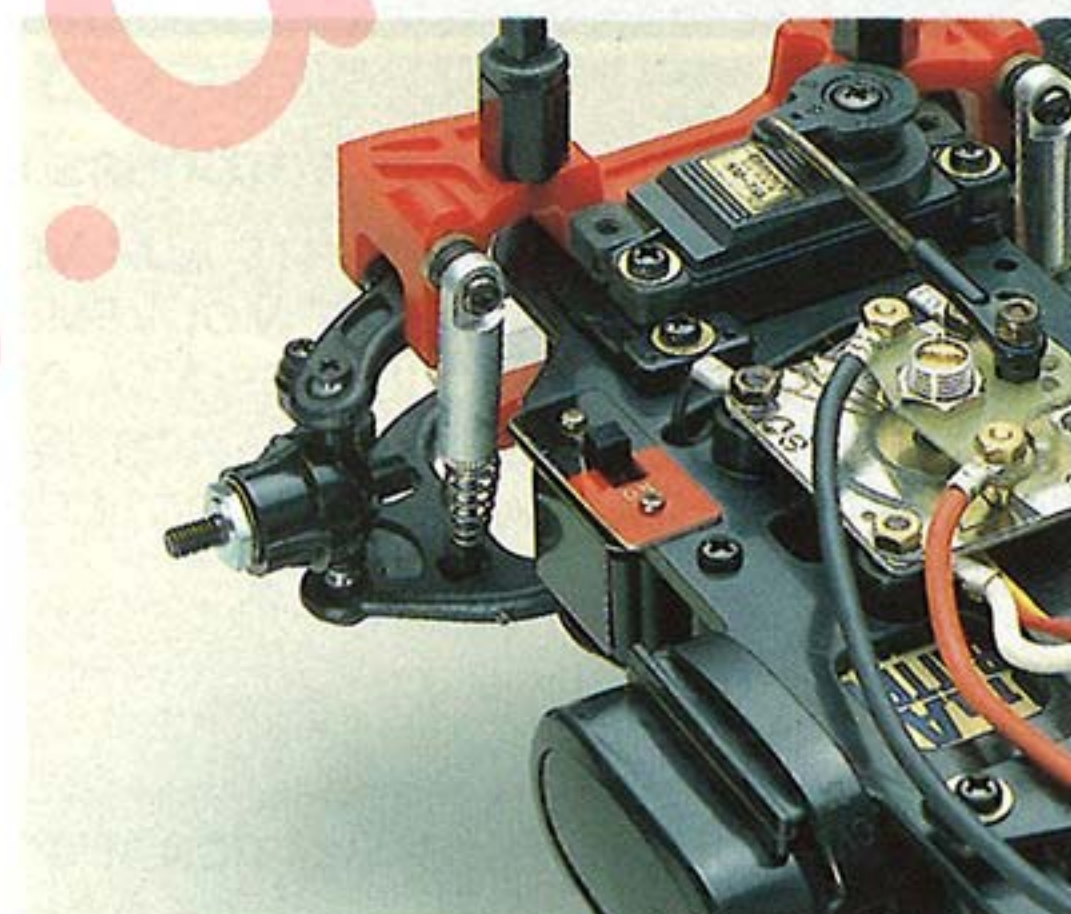

DOUBLE-WISHBONE INDEPENDENT SUSPENSION WITH FRICTION SHOCKS FRONT AND REAR. GOOD ROADHOLDING.

SUSPENSION AV ET AR À DOUBLES BRAS ET AMORTISSEURS À FRICTION. BONNE TENUE DE ROUTE.



OPERATING HEADLIGHTS.

PHARES FONCTIONNELS.





#### THE GREAT LITTLE PLAZMA CONTINUES, EVEN BETTER THAN EVER!

A GOOD COMPETITOR AGAINST CARS COSTING SIX TIMES AS MUCH, PLAZMA OFFERS "GO" WITH A CAPITAL "G"! SLIDING PILLAR FRONT SUSPENSION ALLOWS INDEPENDENT WHEEL MOVEMENT WHILE KEEPING THE WHEELS PERPENDICULAR TO THE TRACK. LIVE REAR AXLE IS LOCATED AND SPRUNG BY THE FRP CHASSIS PLATE AND A FRICTION MONO-SHOCK. TWIN BALL BEARINGS ON REAR AXLE. OPTIONAL 4WD. QUALITY ALUMINUM PARTS.

#### REQUIRED FOR OPERATION/ < > : PLAZMA MKIII LIMITED

● 2-CHANNEL RADIO CONTROL SET ● 7.2V-1200mAh NiCd BATTERY PACK ● CHARGER ● POLYCA COLOR PAINT < ● MOTOR >

#### Technical Data/< >: PLAZMA MKIII LIMITED

① Length/350mm(13.8in) ② Width/170mm(6.7in) ③ Height/80mm(3.1in) ④ Wheelbase/200mm(7.9in) ⑤ Ground Clearance/5mm(0.2in) ⑥ Front Track/137mm(5.4in) ⑦ Rear Track/133mm(5.2in) ⑧ Tires/(F)47φ×23mm(1.9×0.9in);(R)52φ×35mm(2.0×1.4in) ⑨ Total Weight/870g(31oz) ⑩ Gear Ratio/3.7:1 ⑪ Motor/Le Mans 600E(Included)<Le Mans 240/480Type;Not included> ⑫ Battery/7.2V-1200mAh(Not included) ⑬ Radio/2-Channel(Not included)

#### Technische Daten

① Longueur ② Largeur ③ Hauteur ④ Empattement ⑤ Garde au sol ⑥ Voie Avant ⑦ Voie Arrière ⑧ Roue ⑨ Poids Total ⑩ Proportion Dembrayage ⑪ Moteur ⑫ Nicad

#### LA GRANDE PETITE PLAZMA TOUJOURS PRÉSENTE ET ENCORE AMÉLIORÉE!

UNE EXCELLENTE CONCURRENTE AUX VOITURES SIX FOIS PLUS CHERES! LA SUSPENSION AV À PILIERS PERMET LE MOUVEMENT INDÉPENDANT DES ROUES, TOUT EN LES MAINTENANT PERPENDICULAIRES À LA ROUTE. L'AXE ARRIÈRE EST SUSPENDU PAR LA PLAQUE FRP DU CHÂSSIS ET UN AMORTISSEUR À FRICTION. DOUBLE ROULEMENT À BILLES SUR L'AXE AR. 4WD EN OPTION. COMPOSANTS EN ALUMINIUM DE QUALITÉ.

#### ACCESSOIRES REQUIS ET DÉCORATION SUGGÉRÉE/ < > : PLAZMA MKIII LIMITED

● ENSEMBLE RADIO 2 VOIES ● BATTERIE 7,2V-1200mAh ● CHARGEUR ● PEINTURES POLYCA < ● MOTEUR >



## PLAZMA MKIII KS-2

ELECTRIC POWERED SUPER-LIGHT RACING CAR  
NO.3151 • 14800

## PLAZMA MKIII LIMITED α-II

ELECTRIC POWERED SUPER-LIGHT RACING CAR  
NO.3152 • 24000

1:12 SCALE

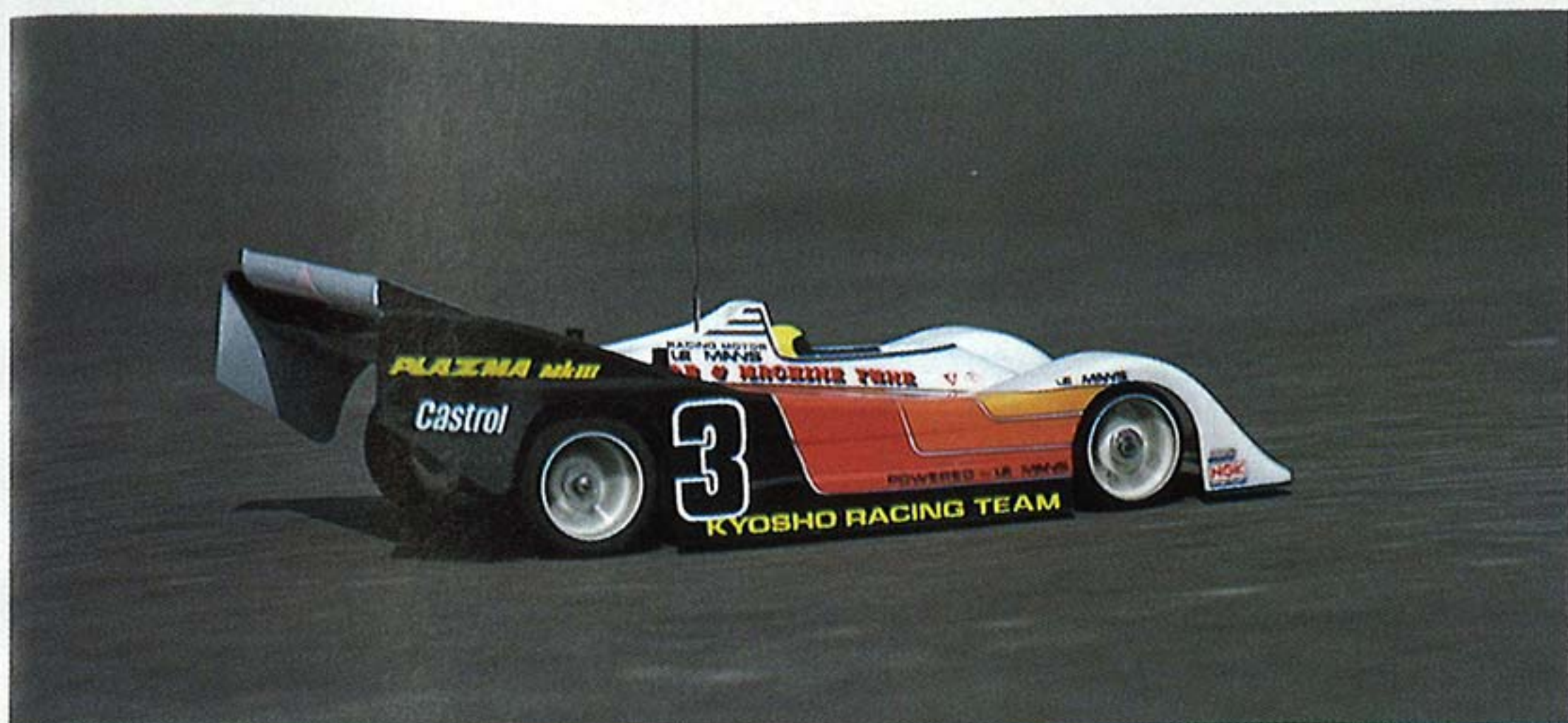

1] PILLAR-TYPE INDEPENDENT FRONT SUSPENSION.

2] DIRECT-MOUNTED SERVO SAVER.

3] MOLDED SPONGE HIGH-GRIP TIRES.

4] STIFF LIGHT FRP PLATE CHASSIS.

5] OIL-FILLED SHOCK ABSORBER.

6] POWERFUL LeMANS 600E MOTOR (INCLUDED).

7] ALUMINUM REAR AXLE CARRIER.

8] REAR AXLE BALL BEARING (X2)

1. SUSPENSION AV INDÉPENDANTE.

2. SAUVE-SERVO INTÉGRAL.

3. PNEUS MOULÉS EN MOUSSE À HAUTE ADHÉRENCE.

4. CHÂSSIS RIGIDE EN FRP.

5. AMORTISSEUR HYDRAULIQUE.

6. MOTEUR PUISSANT LeMANS 600E (INCLUS).

7. SUPPORT D'AXE AR EN ALUMINIUM.

8. ROULEMENT D'AXE AR (X2)

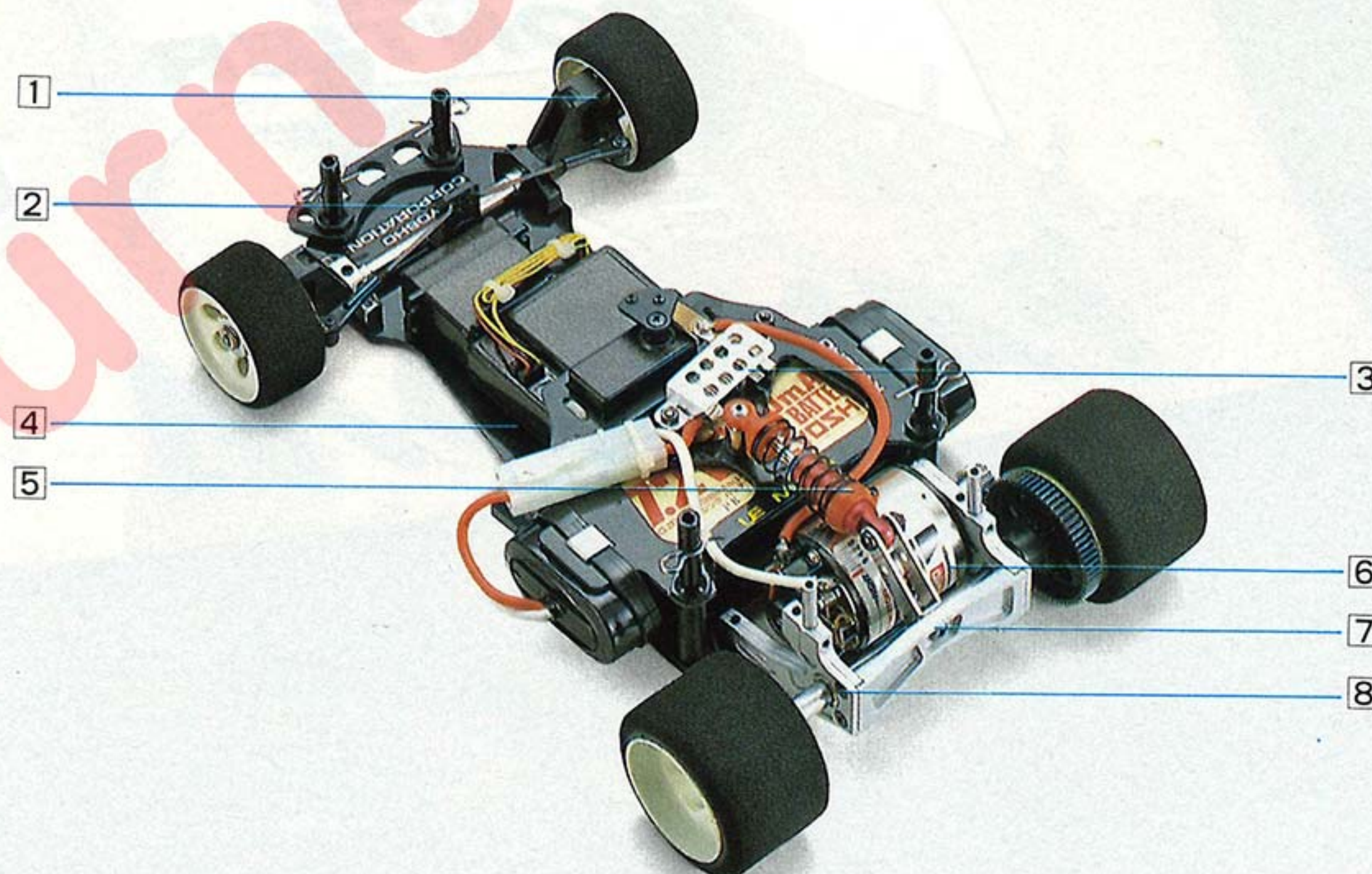

### ■ PLAZMA MKIII LIMITED α-II

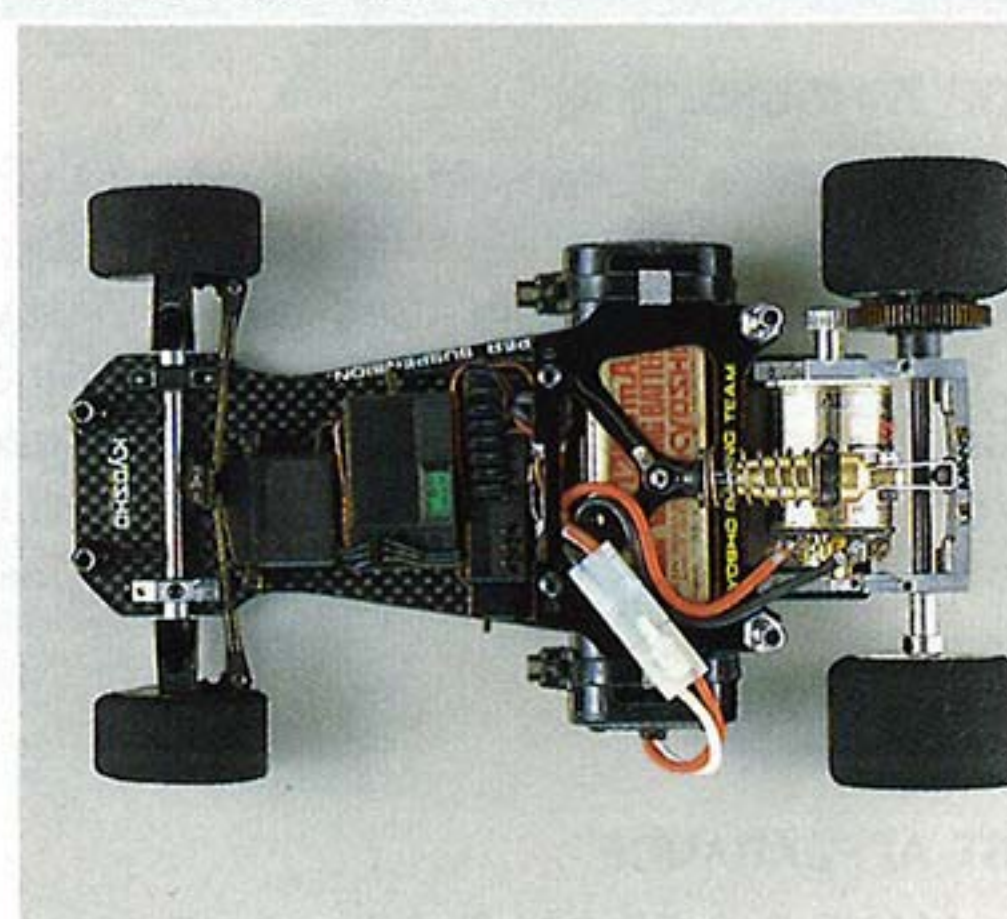

- SUPER-STRONG CARBON-FIBER/EPOXY CHASSIS PLATE.
- HIGH-STRENGTH 17S ALLOY REAR AXLE CARRIERS.
- HIGH-PERFORMANCE PRESSURE-TYPE REAR SHOCK ABSORBER.
- EIGHT BALL BEARINGS FOR MINIMUM FRICTION.

- CHÂSSIS SUPER RIGIDE EN FIBRE DE CARBONE/ÉPOXY
- SUPPORTS D'AXE AR EN ALLIAGE 17S TRÈS RÉSISTANT
- AMORTISSEUR AR À PRESSION, DE HAUTE PERFORMANCE
- HUIT ROULEMENTS À BILLES EN VUE D'ANNULER LES PERTES DE FRICTION.

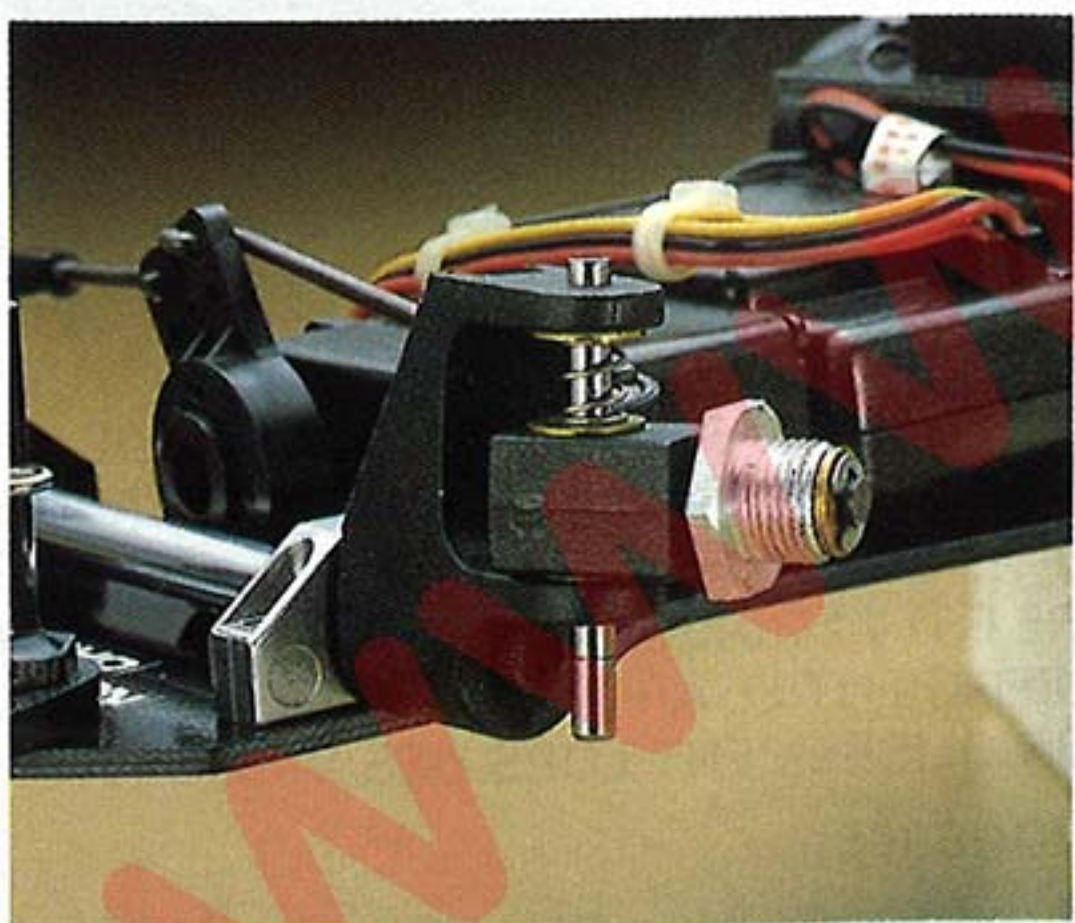

PILLAR-TYPE INDEPENDENT FRONT SUSPENSION.

SUSPENSION AV INDÉPENDANTE TYPE PILIER.

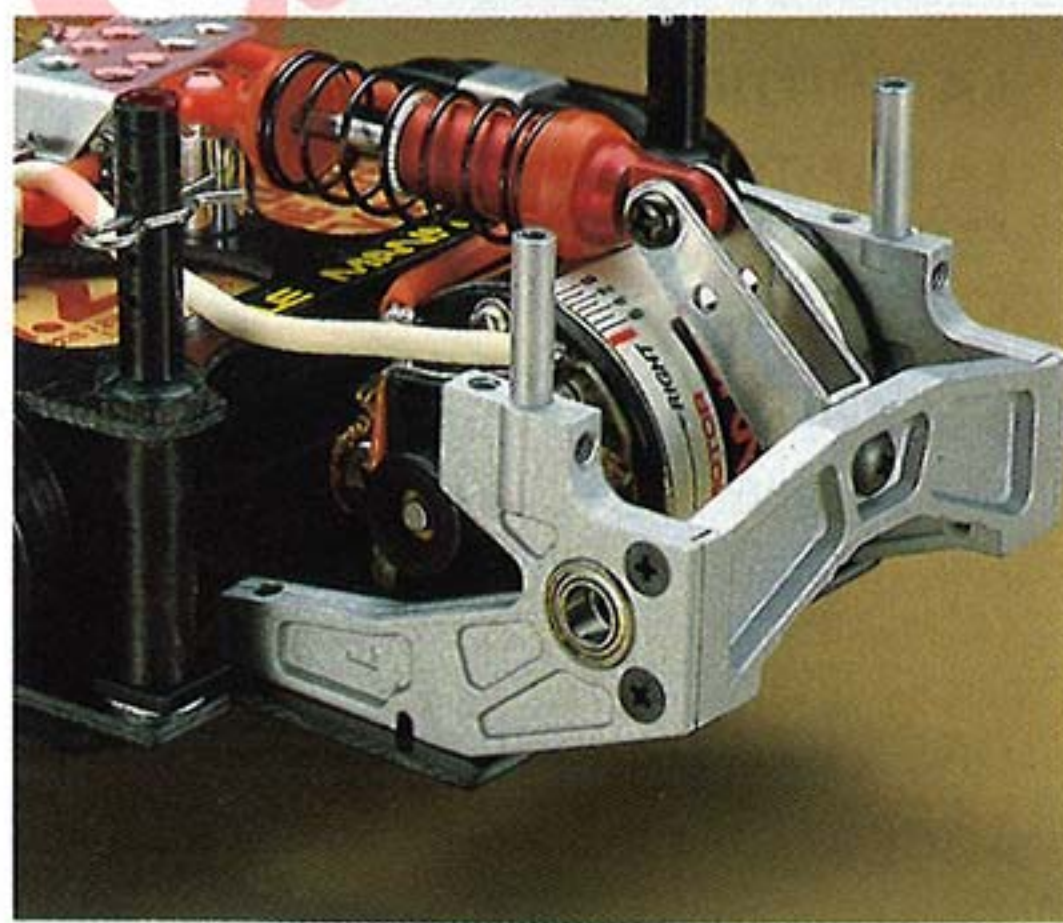

REAR AXLE BALL BEARING (X2) FOR MINIMUM FRICTION, HIGHEST SPEED.

AXE AR SUR 2 ROULEMENTS À BILLES POUR UNE RÉSTANCE RÉDUITE ET UNE PLUS GRANDE VITESSE.



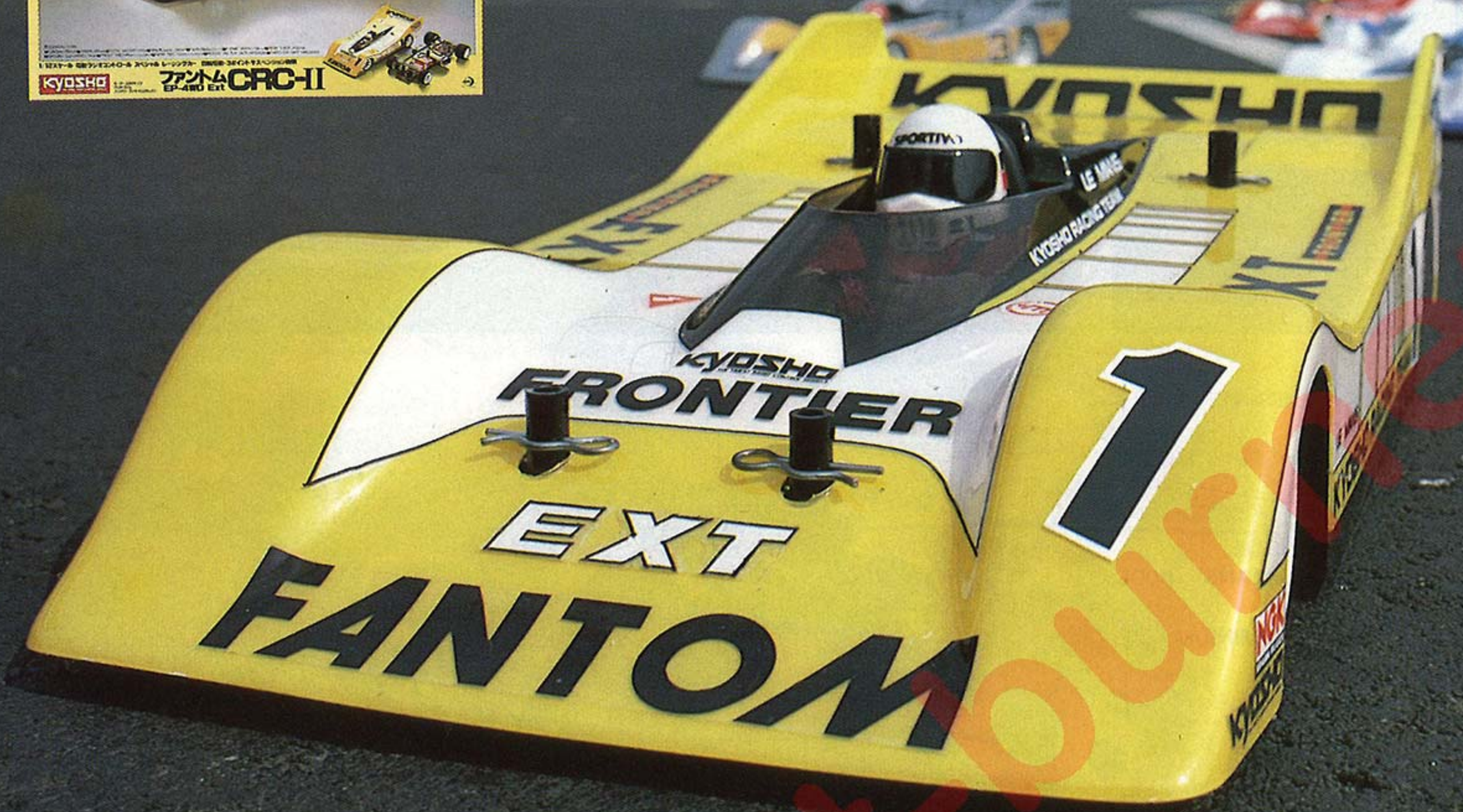

#### THE ULTRA-LIGHT ELECTRIC COMPETITION CAR FOR WINNERS.

FANTOM EXT is a top contender for First Place whenever it races. Extensive use of magnesium and careful engineering results in an energy-saving, performance-enhancing total weight of 880g, right at the allow-able minimum. An ingenious four-wheel drive system uses twin one-way clutches to permit the front wheels to freewheel on the straights and to transmit power in the corners when additional traction is needed. Chain drive system is light, strong, and reliable. Rear differential with adjustable action keeps full power on the road through corners by eliminating slip. Double-decker chassis is stiff, allowing the 3-point suspension to absorb road irregularities. Ball bearing are featured at every friction point to minimize power loss.

#### REQUIRED FOR RUNNING/RECOMMENDED FOR BEST APPEARANCE

● RADIO CONTROL SET (2-CHANNEL) ● MOTOR (Le MANS 240 OR 360 TYPE) ● BATTERY (7.2V-1200mAh NiCd) ● BATTERY CHARGER ● POLYCA COLOR PAINTS

#### Technical Data

①Length/350mm(13.7in)②Width/170mm(6.7in)③Height/80mm(3.1in)④Wheelbase/200mm(7.9in)⑤Ground Clearance/4mm(0.16in)⑥Front Track/134mm(5.3in)⑦Rear Track/133mm(5.2in)⑧Tires/(F)47φ×23mm(1.8×0.9in);(R)47φ×23mm(1.8×0.9in)⑨Total Weight/880g(31.0oz)⑩Gear Ratio/3.7:1⑪Motor/Le Mans 240/480Type(Not included)⑫Battery/7.2V-1200mAh(Not included)⑬Radio/2-Channel(Not included)

#### Technische Daten

①Longueur②Largeur③Hauteur④Empattement⑤Garde au sol⑥Voie Avant⑦Voie Arrière⑧Roue⑨Poids Total⑩Proportion D'embrayage⑪Moteur⑫Nicad

#### LA VOITURE ÉLECTRIQUE DE COMPÉTITION DESTINÉE AUX GAGNANTS

LA FANTOM EXT EST UNE CONCURRENTE SÉRIEUSE DÈS QU'ELLE PARTICIPE À UNE COURSE. L'APPLICATION GÉNÉRALISÉE DU MAGNÉSIUM ET LA CONCEPTION MÉCANIQUE DE LA VOITURE ONT PERMIS UNE ÉCONOMIE INTENSIVE D'ÉNERGIE, LE POIDS TOTAL AYANT PU ÊTRE LIMITÉ À 880g SEULEMENT. LA VOITURE EST PROPULSÉE PAR UNE TRANSMISSION INGÉNIEUSE DES 4 ROUES PAR L'INTERMÉDIAIRE DE DEUX EMBRAYAGES À SENS UNIQUE QUI LAISSENT TOURNER LES ROUES AV LIBREMENT DANS LES LIGNES DROITES, MAIS QUI LES ENTRAÎNENT DANS LES VIRAGES LORSQU'UNE TRACTION SUPPLÉMENTAIRE EST REQUISE. LA CHAÎNE DE TRANSMISSION EST LÉGÈRE, SOLIDE ET FIABLE. LE DIFFÉRENTIEL AR EST RÉGLABLE ET ASSURE UNE TRACTION ININTERROMPUE ET SANS GLISSEMENT LORS DES VIRAGES.

#### ACCESSOIRES REQUIS. DÉCORATION SUGGÉRÉE.

● RADIO 2 VOIES ● BATTERIE NiCad 7,2V-1200mAh ● CHARGEUR ● MOTEUR ● PEINTURE POLYCA ●



**FANTOM EP-4WD EXT "CRC-II,"**  
ELECTRIC POWERED SPECIAL RACING CAR  
NO.3075 • 23000

**FANTOM EP-4WD EXT "BW SPIDER,"**  
ELECTRIC POWERED SPECIAL RACING CAR  
NO.3074 • 23000

1:12 SCALE



- 1 FRONT-WHEEL DRIVE SYSTEM ENGAGES ONLY WHEN CORNERING. FREEWHEELS ON STRAIGHTS TO SAVE BATTERY ENERGY.
- 2 CAR HAS 4-WHEEL DRIVE/3-POINT SUSPENSION, YET WEIGHT ONLY 880G DUE TO MAGNESIUM PARTS.
- 3 DOUDLE-DECKER CHASSIS IS JOINED AT 4 POINTS FOR MAXIMUM RESISTANCE TO FLEXING.
- 4 CHASSIS IS OPTIMIZED FOR 4-WHEEL DRIVE.
- 5 EXTENSIVE USE OF CAST MAGNESIUM CUTS WEIGHT.
- 6 DIFFERENTIAL IS STRONG, LIGHT AND ADJUSTABLE.
- 7 17S ALUMINUM ALLOY FRONT AXLE IS VERY LIGHT, STRONG.
- 8 DIRECT-MOUNTED SERVO SAVER INCLUDED.
- 9 LIGHTWEIGHT CHAIN DRIVE SYSTEM IS SIMPLE, STRONG, RELIABLE, AND ENERGY EFFICIENT.
- 10 3-POINT SUSPENSION GIVES GREAT CORNERING WORK.
- 11 CAR OPTIMIZED FOR LeMANS 480T MOTOR (RECOMMENDED).
- 12 BALL BEARINGS USED AT ALL FRICTION POINTS.

1. LA TRACTION AV NE S'ENGAGE QUE DANS LES VIRAGES. EN VUE D'ÉCONOMISER L'ÉNERGIE.
2. CETTE VOITURE 4 ROUES MOTRICES ET À SUSPENSION 3 POINTS NE PÈSE NÉANMOINS QUE 880g GRÂCE À L'APPLICATION DE MAGNÉSIUM.
3. DOUBLE CHÂSSIS À 4 POINTS DE JONCTION POUR UNE RIGIDITÉ MAXIMALE.
4. CHÂSSIS SPÉCIALEMENT ÉTUDIÉ POUR LE 4WD
5. POIDS RÉDUIT GRÂCE À L'UTILISATION DU MAGNÉSIUM.
6. DIFFÉRENTIEL FIABLE, LÉGER ET RÉGLABLE.
7. AXE AV EN ALLIAGE 17S, LÉGER MAIS RÉSISTANT.
8. SAUVE-SERVO INTÉGRAL INCLUS.
9. LE SYSTÈME DE TRANSMISSION PAR CHAÎNE EST SIMPLE, FIABLE ET PROCURE LE MEILLEUR RENDEMENT MÉCANIQUE.
10. LA SUSPENSION EN 3 POINTS ASSURE UN COMPORTEMENT IDÉAL EN VIRAGE.
11. LE MOTEUR LeMANS 480T EST IDÉAL POUR CETTE VOITURE.
12. ROULEMENTS À BILLES SUR TOUTES LES PIÈCES ROTATIVES.

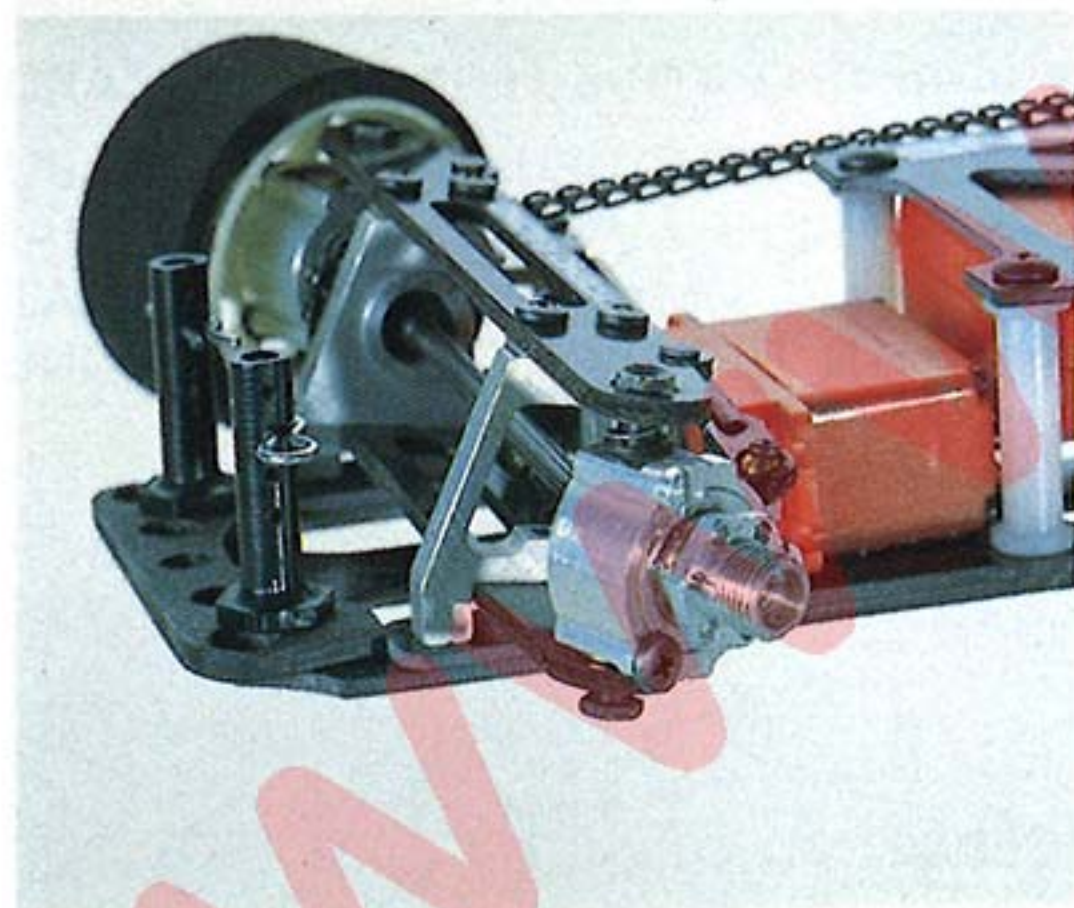
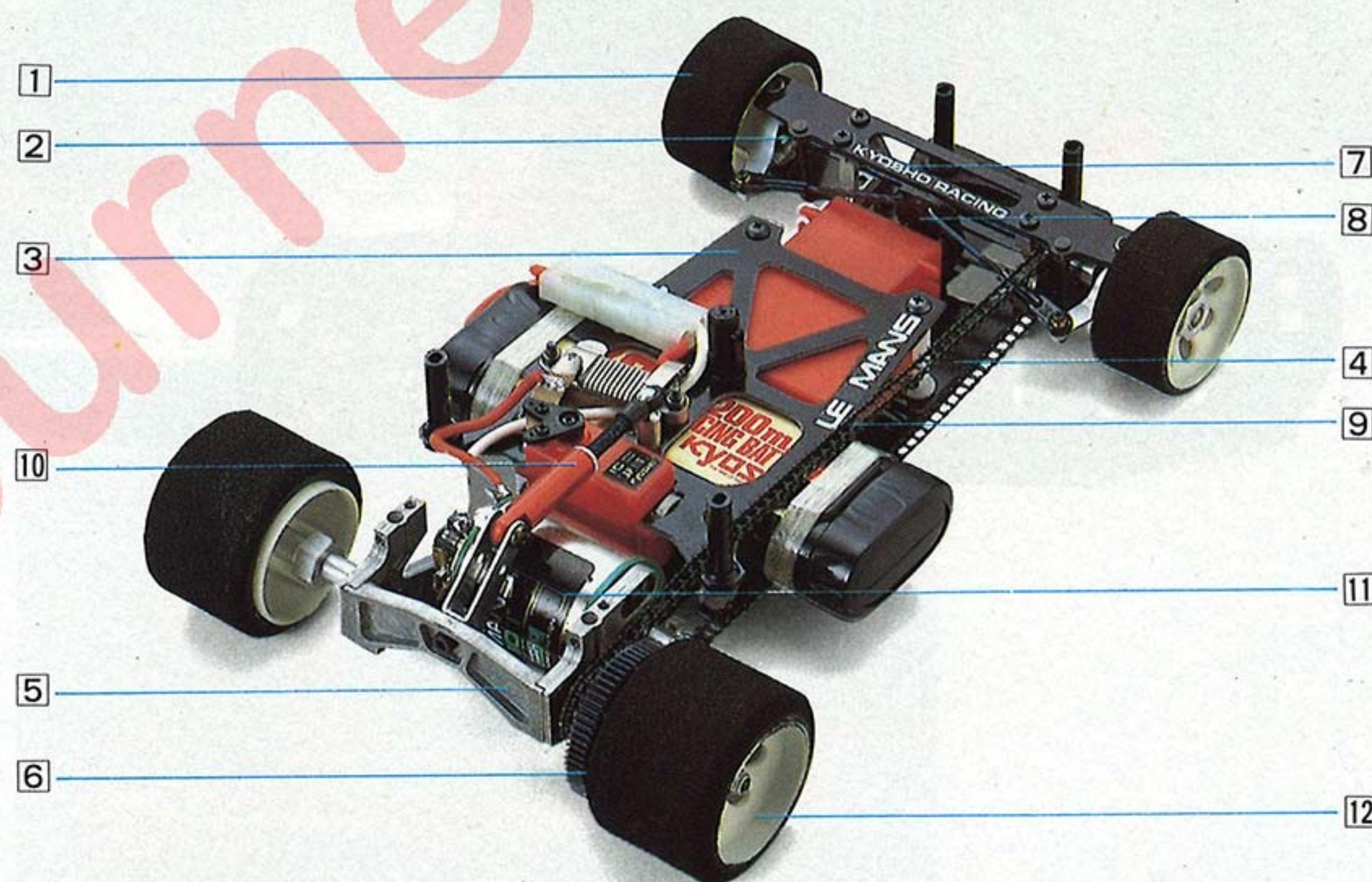

FRONT-WHEEL DRIVE SYSTEM ENGAGES ONLY WHEN CORNERING, FREEWHEELS ON STRAIGHTS TO SAVE BATTERY ENERGY.

LA TRACTION AV NE S'ENGAGE QUE DANS LES VIRAGES. EN VUE D'ÉCONOMISER L'ÉNERGIE.

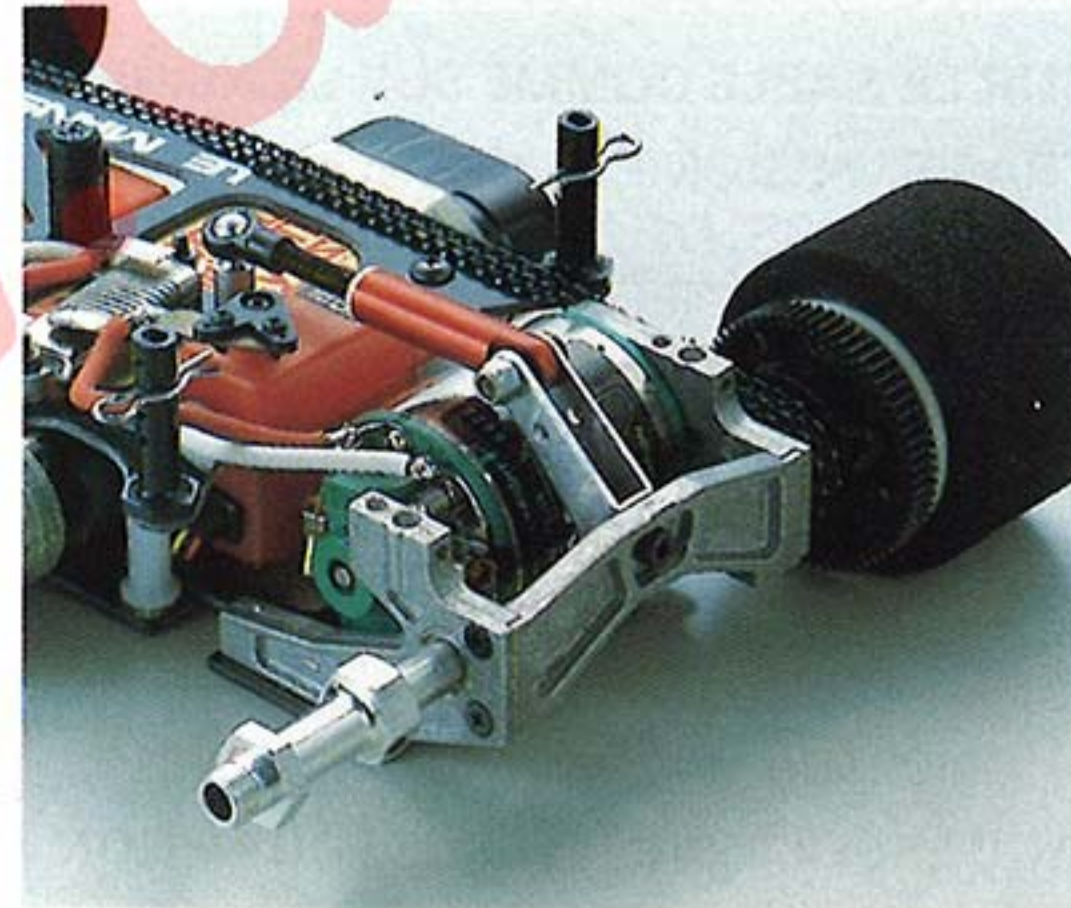

CAR HAS 4-WHEEL DRIVE/3-POINT SUSPENSION, YET WEIGHS ONLY 880G DUE TO MAGNESIUM PARTS.

CETTE VOITURE À 4 ROUES MOTRICES ET À SUSPENSION EN 3 POINTS NE PÈSE NÉANMOINS QUE 880g GRÂCE À L'APPLICATION DE MAGNÉSIUM.

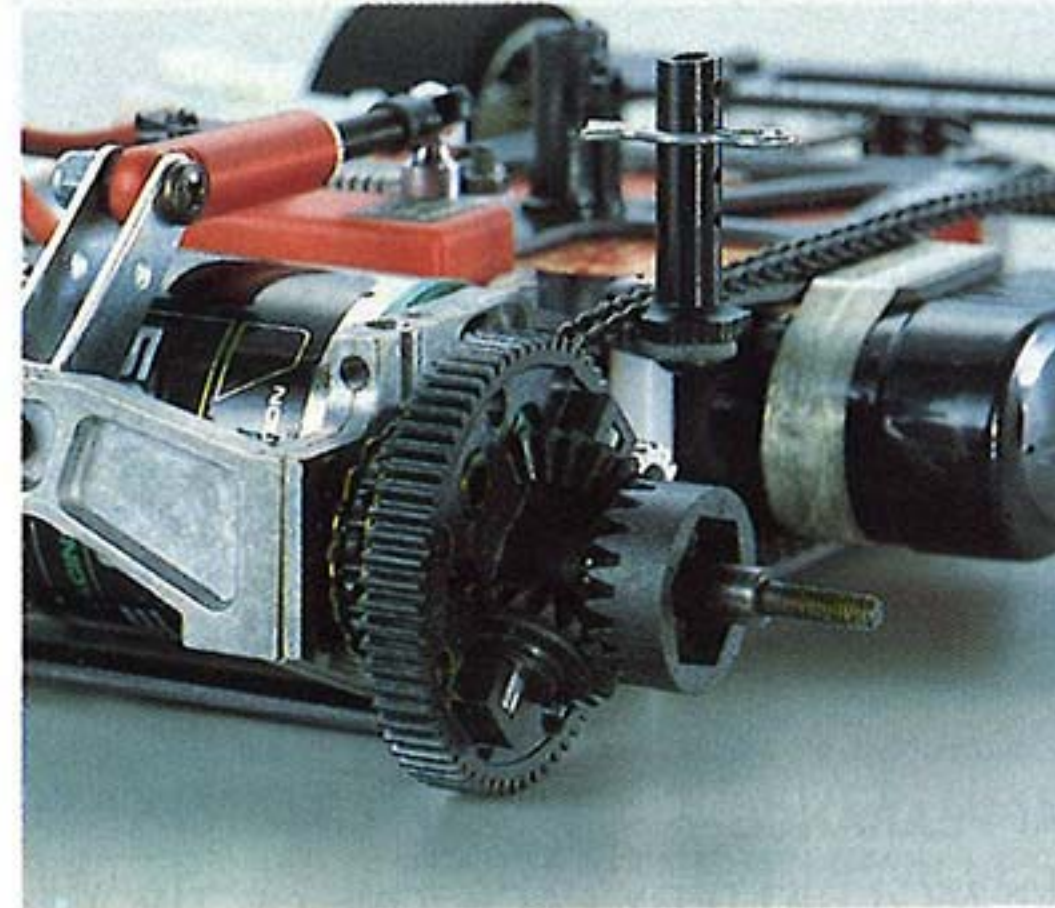

DIFFERENTIAL IS STRONG, LIGHT, AND ADJUSTABLE.

DIFFÉRENTIEL FIABLE, LÉGER ET RÉGLABLE.

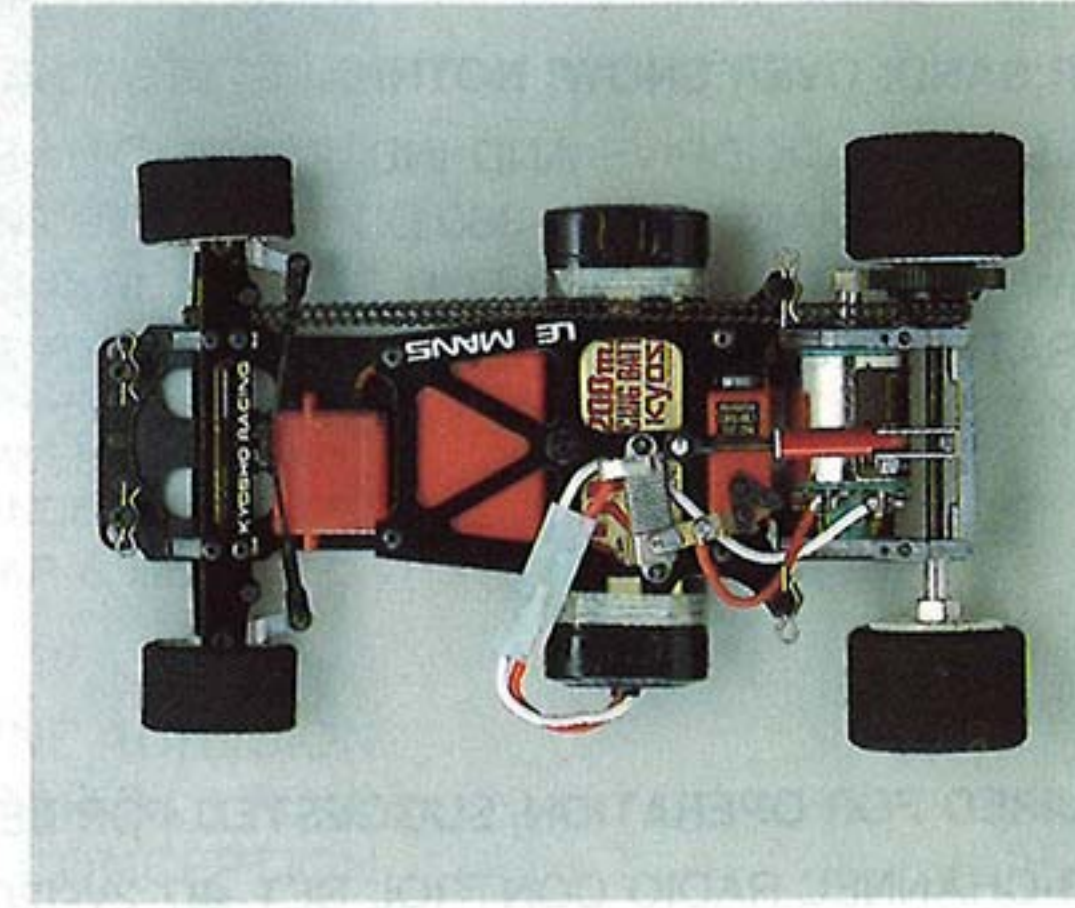

DOUBLE-DECKER CHASSIS IS JOINED AT 4 POINTS FOR MAXIMUM RESISTANCE TO TLEXING.

DOUBLE CHÂSSIS À 4 POINTS DE JONCTION POUR UNE RIGIDITÉ MAXIMALE.





**OVER SAND! OVER SNOW! NOTHING STOPS THE BLIZZARD ALL-TERRAIN VEHICLE!**

ENDLESS-TRACK DRIVE AND INDEPENDENTLY SPRUNG BOGEYS TO SNAKE OVER OBSTACLES. TWIN MABUCHI RS-380 DRIVE MOTORS WITH TWIN STEPLESS SPEED CONTROLLERS (FORWARD AND REVERSE) FOR SHARP-TURNING DIFFERENTIAL-TRACK STEERING. SERVO OPERATED PLOW. USES READILY AVAILABLE 7.2V-1200mAh NiCd BATTERY PACK. CLEAR, EASY-TO-FOLLOW ASSEMBLY INSTRUCTIONS.

**REQUIRED FOR OPERATION/SUGGESTED FOR BEST APPEARANCE**

- 2/3-CHANNEL RADIO CONTROL SET ● 7.2V-1200mAh NiCd BATTERY PACK (ONE OR TWO)
- CHARGER
- POLYCA COLOR PAINT

**Technical Data**

① Length/360mm(14.2in) ② Width/304mm(12.0in) ③ Height/225mm(8.9in) ④ Wheelbase/300mm(11.8in) ⑤ Caterpillar /90×750mm(3.5×29.5in) ⑥ Total Weight/2400g(84.7oz) ⑦ Gear Ratio/12 : 1/32 : 1 ⑧ Motor/RS-380S × 2(Included) ⑨ Battery/7.2V-1200mAh(Not included) ⑩ Radio/2-Channel(Not included)

**Technische Daten**

① Longueur ② Largeur ③ Hauteur ④ Empattement ⑤ Poids Total ⑥ Proportion D'embrayage ⑦ Moteur ⑧ Nicad

**SUR LE SABLE COMME SUR LA NEIGE! RIEN N'ARRETE LE TOUS-TERRAINS BLIZZARD!**

TRANSMISSION PAR CHENILLES ET BOGIES INDÉPENDANTS, DEUX MOTEURS MABUCHI RS-380S, DEUX VARIATEURS PROGRESSIFS (MARCHE AV ET AR). CONDUITE PAR COMMANDE DIFFÉRENTIELLE DES CHENILLES. PELLE COMMANDÉE PAR SERVO. BATTERIE NiCad 7,2V-1200mAh STANDARD. MANUEL D'INSTRUCTIONS TRÈS SOIGNÉ.

**ACCESSOIRES REQUIS. DÉCORATION SUGGÉRÉE**

- RADIO 2 OU 3 VOIES • 1 OU 2 BATTERIES NiCad 7,2V-1200mAh • CHARGEUR •
- PEINTURE POLYCA •



# THE BLIZZARD

## ELECTRIC POWERED R/C CATERPILLAR TRACTOR

1:12 SCALE  
NO.2435 • 19500



- 1) BLINKING PATROL LIGHT (OPTION).
- 2) CLEAR BODY MADE BY POLYCARBONATE.
- 3) REALISTIC SCALE FEELING CAN BE ENJOYED WITH AN OPTIONAL PARTS OF FORDING MUFFLER.
- 4) CHANGING DIRECTION CONTROLLER.
- 5) LARGE SIZE INJECTION MOLDED CHASSIS.
- 6) GEAR BOX ALREADY ASSEMBLED AND GEAR RATIO CAN SIMPLY BE CHANGED WITH A HEXAGONAL WRENCH.
- 7) BATTERY CAN BE INSTALLED EITHER 1 PIECE OR 2 PIECES.
- 8) FORWARD AND REVERSE CONTROLLER.
- 9) TRAILING SYSTEM. INDEPENDENT SUSPENSION.
- 10) SUPER WIDE CATERPILLAR BEING MOLDED AS A WHOLE UNIT AND EASY TO ASSEMBLE.
- 11) AN OPTIONAL POWER SHOVEL CAN BE INSTALLED AND ENJOY ACTION WITH 3 CHANNEL RADIO CONTROL.

1. PHARE CLIGNOTANT (EN OPTION).
2. CARROSSERIE EN POLYCARBONATE TRANSPARENT.
3. ASPECT RÉALISTE, POUVANT ÊTRE COMPLÉTÉ EN OPTION.
4. VARIATEUR DE DIRECTION.
5. CHÂSSIS SURDIMENSIONNÉ MOULÉ.
6. CARTER D'ENGRENAGE PRÉASSEMBLÉ. RAPPORT DE TRANSMISSION RÉGLABLE À L'AIDE D'UNE CLÉ ALLEN.
7. CHOIX DE 1 OU 2 BATTERIES.
8. INVERSEUR DE MARCHE.
9. SUSPENSION INDÉPENDANTE À BRAS LONGITUDINAUX.
10. CHENILLES INTÉGRALE, FACILE À ASSEMBLER.
11. POSSIBILITÉ D'INSTALLER UNE PELLE FONCTIONNELLE COMMANDÉE PAR LE TROISIÈME CANAL DE LA RADIO.

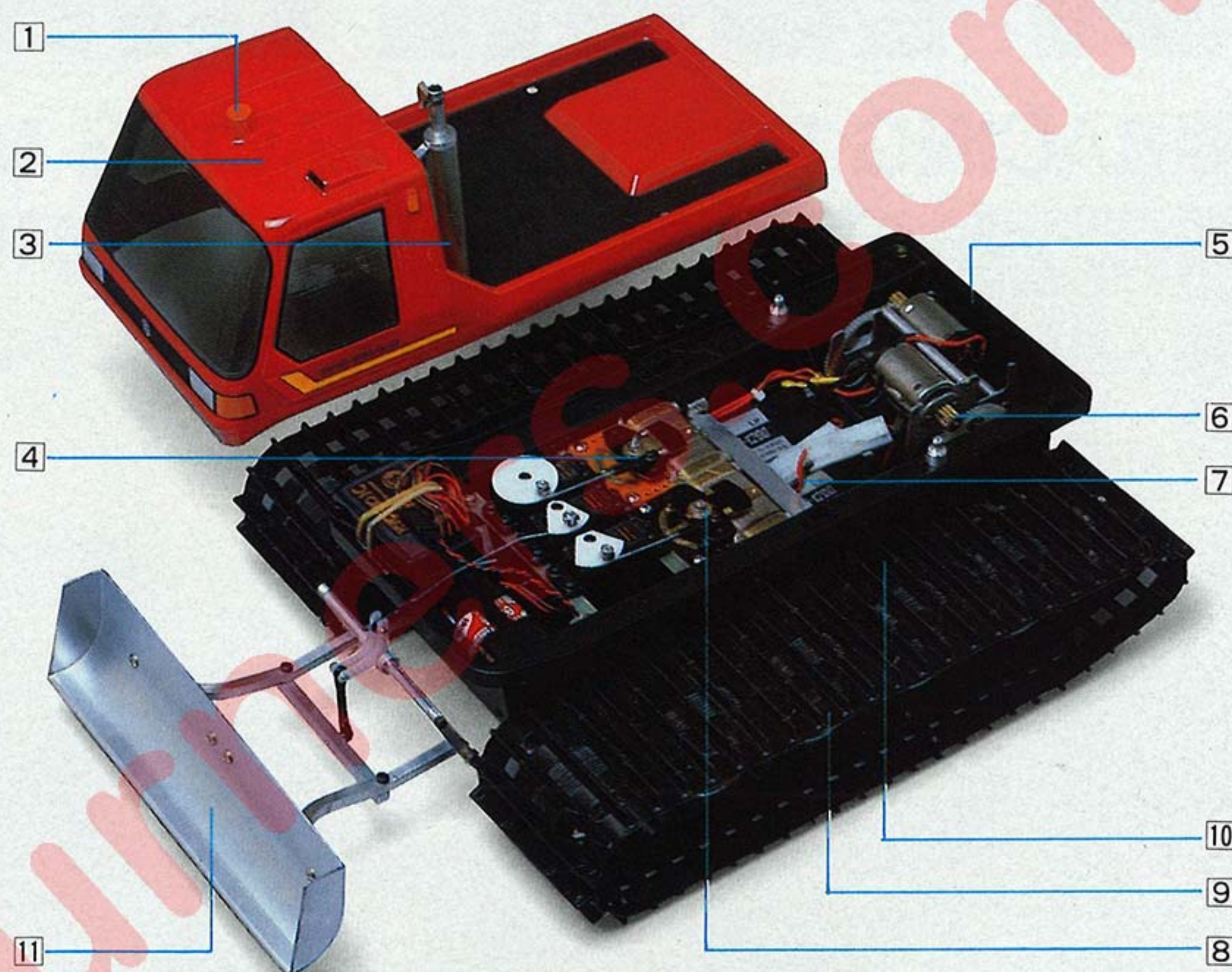

CAN BE RUN AT ANY SEASON AND ANYPLACE SUCH AS ON THE SNOW, ICE, SANDY SOIL, SEASIDE AND GRASSLAND ETC. POWERFUL RUNNING AND CLIMB UP A SLOPE OF 45 DEGREE.

LE VÉHICULE PEUT ÊTRE UTILISÉ N'IMPORTE OÙ ET EN TOUTE SAISON, SUR LA GLACE, LA NEIGE, LE SABLE, LA PLAGE, LE GAZON, ETC. IL EST PUISSANT ET PEUT ESCALADER DES PENTES DE 45°.



SUPER WIDE CATERPILLAR TO HAVE BIG GRIP POWER AND 5PIECES EACH SIDE WHEELS HAS AN INDEPENDENCE SUSPENSION. COMPLEX-CATERPILLAR MECHANISM (CATERPILLAR & BELT) BEING INJECTION MOLDED AS A WHOLE UNIT.

CHENILLES EXTRA LARGES, ASSURANT UNE ADHÉSION MAXIMALE AVEC LE SOL. SUSPENSION PAR 2X5 ROULETTES INDÉPENDANTES. CHENILLES DE CONCEPTION INGÉNIÈRE, MOULÉES INTÉGRALEMENT.



# SPECIAL RACING BUGGY

■ RACING PAJERO ■ RACING MONTERO ■ ASSAULT  
■ STINGER 4WD ■ STINGER MKII ■ BURNS 4WD  
■ VANNING ■ PRESTO ■ FANTOM 21-4iS





# ENGINE POWERED VEHICLES



		Scale	Length	Height	Weight	Suspension	Shock Absorber	Ball Bearing	Engine	Drive System	Option Parts
2 W D	RACING PAJERO	1:12	410mm	185mm	1600g	(F)TS (R)TS	4 Oil-Filled Shock Absorbers	(Not included)	ENYA QICKY 09BB	—	△
	RACING MONTERO	1:12	410mm	185mm	1600g	(F)TS (R)TS	//	(Not included)	.09-.11 Class (Not included)	—	△
	ASSAULT	1:10	460mm	160mm	1480g	(F)TS (R)TS	//	(Not included)	OS CZ-1	—	△
4 W D	STINGER MK II	1:10	370mm	110mm	1450g	(F)WS (R)WS	//	5pcs.	.11 Class (Not included)	Belt	◎
	STINGER 4WD	1:10	370mm	110mm	1450g	(F)WS (R)WS	//	3pcs.	.09-.11 Class (Not included)	Chain	◎
	BURNS 4WD	1:8	420mm	160mm	3200g	(F)WS (R)WS	//	18pcs.	.21 Class (Not included)	Soft	◎
	VANNING	1:8	520mm	170mm	3100g	(F)WS (R)WS	//	9pcs.	.21 Class (Not included)	Chain	○
	PRESTO	1:8	520mm	170mm	3100g	(F)WS (R)WS	//	9pcs.	.21 Class (Not included)	Chain	○
	FANTOM 21-4iS	1:8	515mm	130mm	2650g	(F)WS (R)WS	3 Oil-Filled Shock Absorbers	14pcs.	.21 Class (Not included)	Belt	◎

ABBREVIATIONS: POSSIBILITY OF HOP-UP. (◎=HIGH, ○=MODERATE, △=LOW) (F)=FRONT, (R)=REAR, WS=DOUBLE WISHBONES SUSPENSION, TS= TRAILING ARM SUSPENSION  
SS=PILLAR-TYPE INDEPENDENT SUSPENSION.





#### RUN YOUR OWN PARIS-DAKAR RALLY!

THE TWIN RACING PICKUP TRUCKS PAJERO AND MONTERO PACK LOTS OF RACING FUN INTO THEIR COMPACT SIZE! BOTH ARE POWERED BY A PEPPY AND EASY-STARTING "QUICKY" .09 GLOW ENGINE, MADE BY THE FAMOUS MANUFACTURER, ENYA. POWER IS TRANSMITTED TO THE BLOCK-PATTERN TIRES BY AN EFFICIENT SYSTEM OF SEALED GEARBOX AND HARDENED-STEEL CHAIN. SUSPENSION IS INDEPENDENT ON ALL FOUR WHEELS BY TRAILING ARMS AND OIL-FILLED SHOCK ABSORBERS WITH COIL SPRINGS. SUSPENSION PARTS ARE STRONG DIE-CAST ALUMINUM.

#### REQUIRED FOR OPERATION/ < > : RACING MONTERO

● 2-CHANNEL RADIO CONTROL SET ● FUEL ● POLYCA COLOR PAINT ● MICRONLINE STRIPPING TAPE < ● .10 ENGINE >

#### Technical Data/ < > : RACING MONTERO

① Length/410mm(16.1in) ② Width/240mm(9.4in) ③ Height/185mm(4.3in) ④ Wheelbase/235mm(9.2in) ⑤ Ground Clearance/35mm(1.3in) ⑥ Front Track/170mm(6.6in) ⑦ Rear Track/200mm(7.9in) ⑧ Tires/(F)83φ×38mm(3.2in×1.4in);(R)83 φ×38mm(3.2×1.4in) ⑨ Total Weight/1600g(56.2oz) ⑩ Engine/ENYA "QUICKY 09 BB" (Included) < .09-.11 Class Engine; Not included > ⑪ Radio/2-Channel (Not included)

#### Technische Daten

① Longueurs ② Largeurs ③ Hauteurs ④ Empattements ⑤ Gardes au sol ⑥ Voies Avant ⑦ Voies Arrière ⑧ Roues ⑨ Poids Total ⑩ Moteur

#### COURREZ VOTRE PROPRE PARIS-DAKAR!

LES DEUX PICK-UP DE COURSE PAJERO ET MONTERO VOUS PROCURERONT UN MAXIMUM DE PLAISIR. LES DEUX VERSIONS SONT PROPULSÉES PAR LE MOTEUR NERVEUX ET FACILE À DÉMARRER ENYA QUICKY À GLOW-PLUG. LA TRANSMISSION EST ASSURÉE PAR UN CARTER D'ENGRENAGE ÉTANCHE ET UNE CHAÎNE EN ACIER TRAITÉ. QUATRE ROUES INDÉPENDANTES SUSPENDUES PAR BRAS LONGITUDINAUX ET AMORTISSEURS HYDRAULIQUES À RESSORTS HÉLICOÏDAUX. LES ÉLÉMENTS DE LA SUSPENSION SONT INJECTÉS EN ALUMINIUM.

#### ACCESSOIRES REQUIS ET DÉCORATION SUGGÉRÉE/ < > : RACING MONTERO

● RADIOCOMMANDE 2 VOIES ● CARBURANT ● PEINTURES POLYCA ● FILETS ADHÉSIFS MICRONLINE < ● MOTEUR 1,5 À 2,1Cm<sup>3</sup> >



## RACING PAJERO

ENGINE POWERED 10 ENGINE OFF-ROADER  
NO.3039 • 21800

## RACING MONTERO

ENGINE POWERED 10 ENGINE OFF-ROADER  
NO.3037

1:12 SCALE



- 1 HIGH-GRIP BLOCK TREAD TIRES FOR GOOD TRACTION.
- 2 STRONG, LIGHT DIECAST ALUMINUM FRONT TRAILING ARM.
- 3 STRONG, LIGHT NYLON WHEELS FOR LOW UNSPRUNG WEIGHT.
- 4 DIECAST ALUMINUM REAR TRAILING ARM.
- 5 EFFECTIVE OIL-FILLED SHOCK ABSORBERS.
- 6 LIGHT, RELIABLE CHAIN DRIVE SYSTEM.
- 7 CHASSIS COVER TO PROTECT RADIO EQUIPMENT.
- 8 STRONG, SPACIOUS "TUB" TYPE CHASSIS.
- 9 MANIFOLD AND EFFECTIVE MUFFLER (INCLUDED).
- 10 POWERFUL, EASY-STARTING ENYA QUICKY .09 GLOW ENGINE (INCLUDED).
- 11 WIDE REAR TRACK FOR STABILITY, LONG WHEEL TRAVEL.

1. PNEUS PROFILÉS À HAUTE ADHÉRENCE.
2. BRAS DE SUSPENSION LONGITUDINAL INJECTÉ.
3. JANTES RÉSIDANTES EN NYLON, LÉGÈRES AFIN DE RÉDUIRE LES MASSES NON SUSPENDUES.
4. BRAS DE SUSPENSION AR INJECTÉ.
5. AMORTISSEURS HYDRAULIQUES EFFICACES.
6. TRANSMISSION PAR CHAÎNE.
7. COUVERCLE DU COMPARTIMENT RADIO.
8. CHÂSSIS RÉSIDANT.
9. RACCORD ET SILENCIEUX EFFICACE (INCLUS).
10. MOTEUR PUISSANT ET FACILE À DÉMARRER ENYA QUICKY .09 (INCLUS).
11. EMPATTEMENT AR TRÈS LARGE POUR UN MAXIMUM DE STABILITÉ, SUSPENSION LONGUE COURSE.

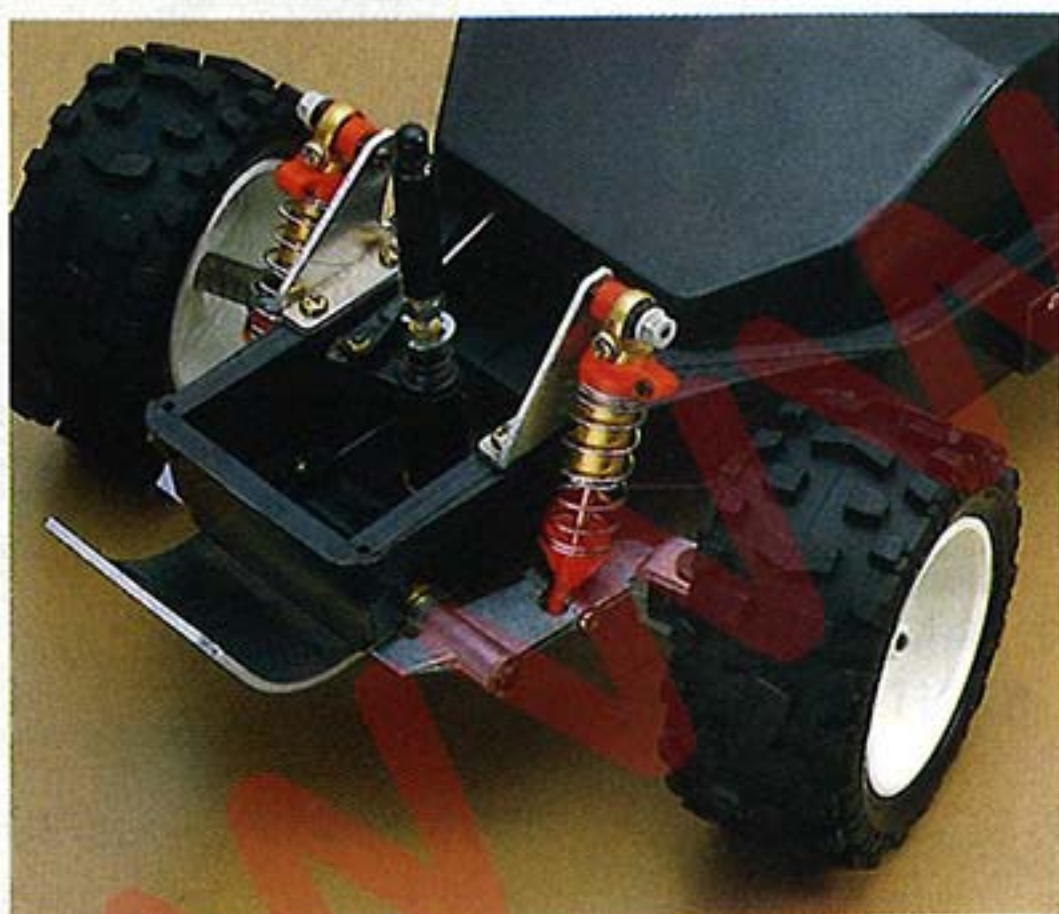
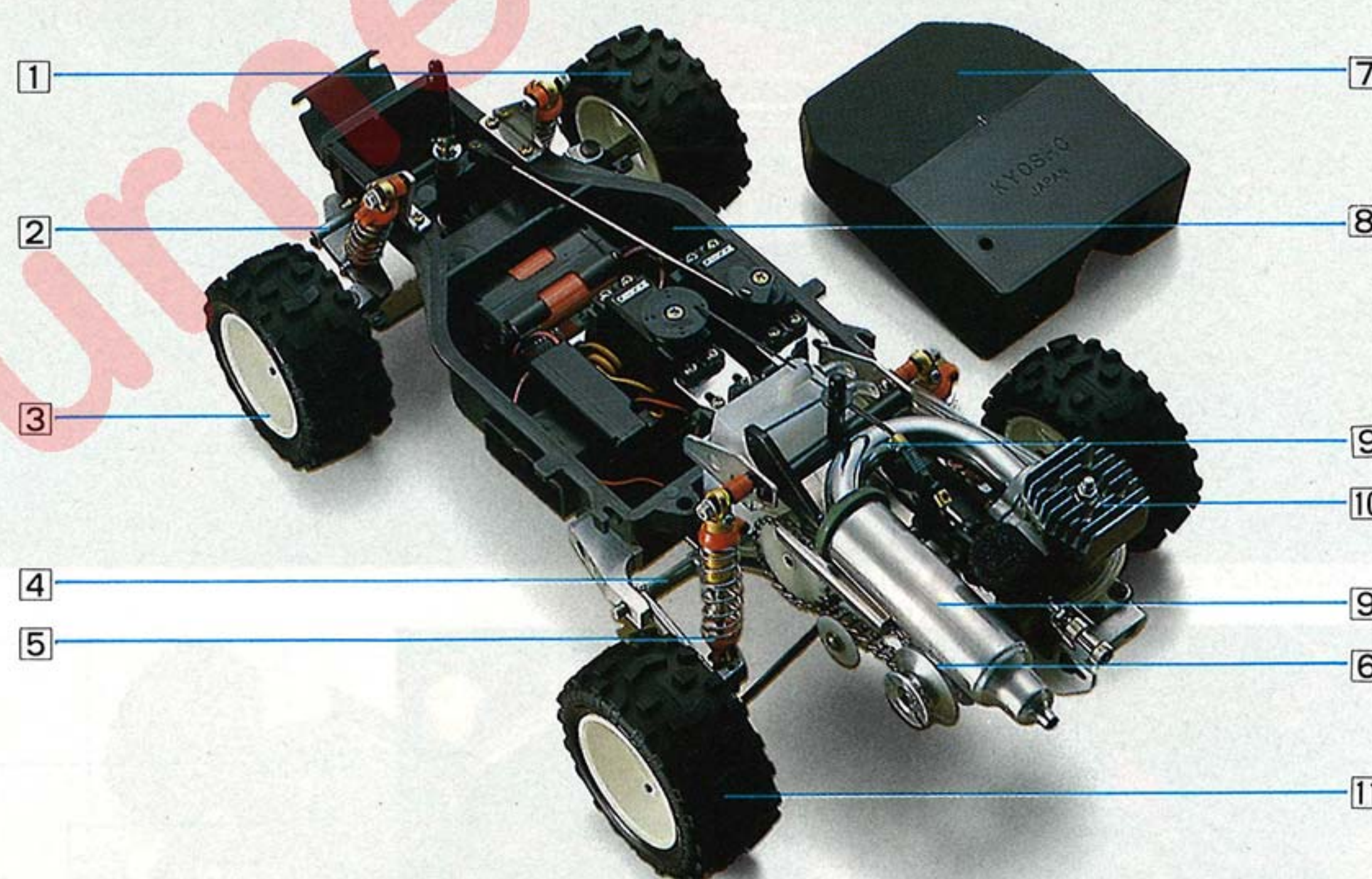

SIMPLE, STRONG, RELIABLE TRAILING ARM FRONT SUSPENSION. CAST ALUMINUM ARM. OIL-FILLED SHOCK FOR EFFECTIVE DAMPING. INDEPENDENT REAR SUSPENSION BY TRAILING ARMS.

SUSPENSION AV PAR BRAS LONGITUDINAUX, SOLIDES, FIABLES ET SIMPLES EN ALUMINIUM INJECTÉ. AMORTISSEURS HYDRAULIQUES. SUSPENSION AR À BRAS LONGITUDINAUX.

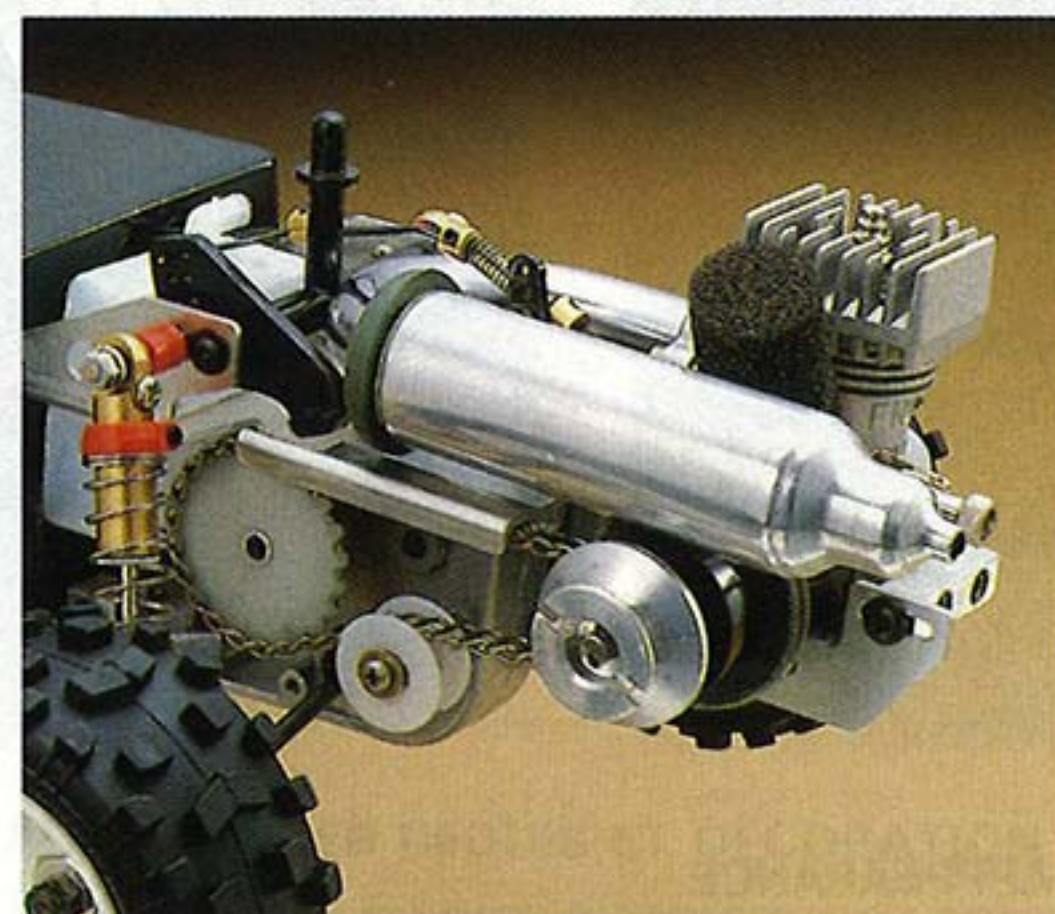
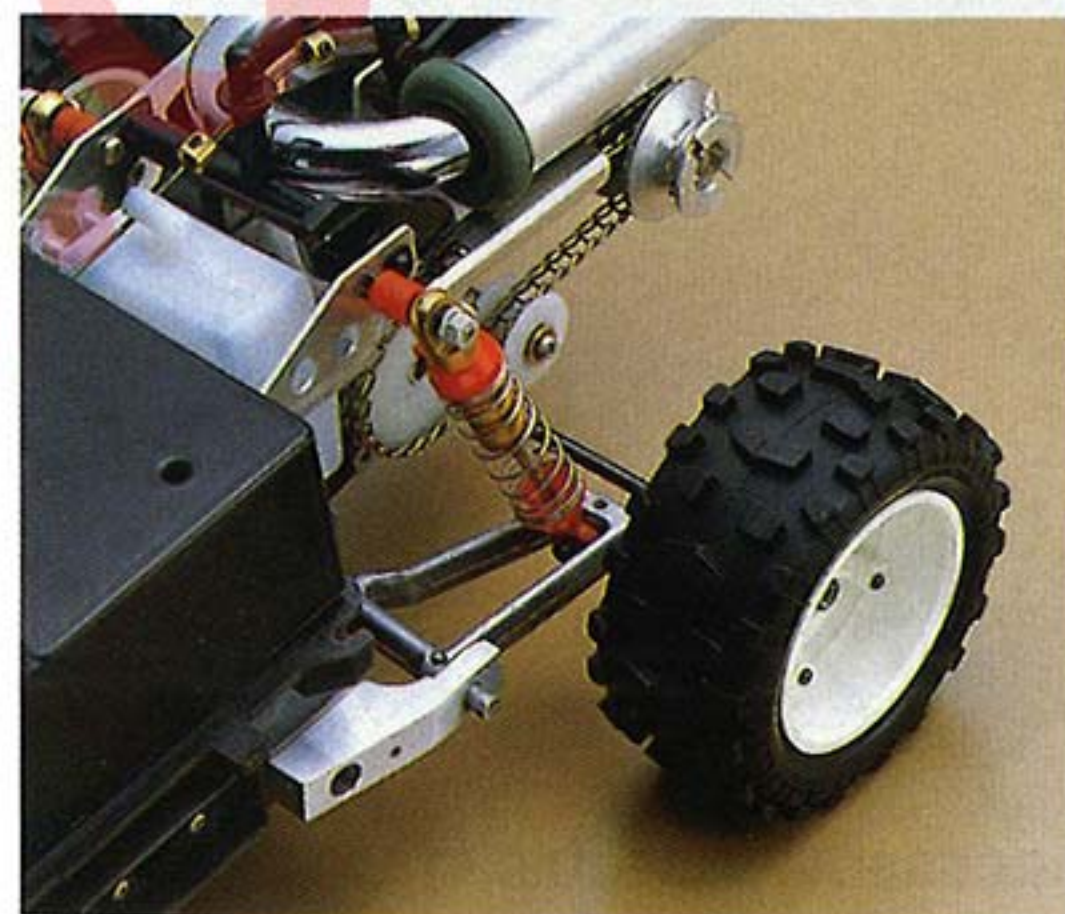

SIMPLE, RELIABLE CHAIN DRIVE SYSTEM WITH HARDENED STEEL DRIVECHAIN. DOUBLE PIVOTTED SWING ARM.

TRANSMISSION PAR CHAÎNE ET BRAS OSCILLANT, SOLUTION SIMPLE ET FIABLE.

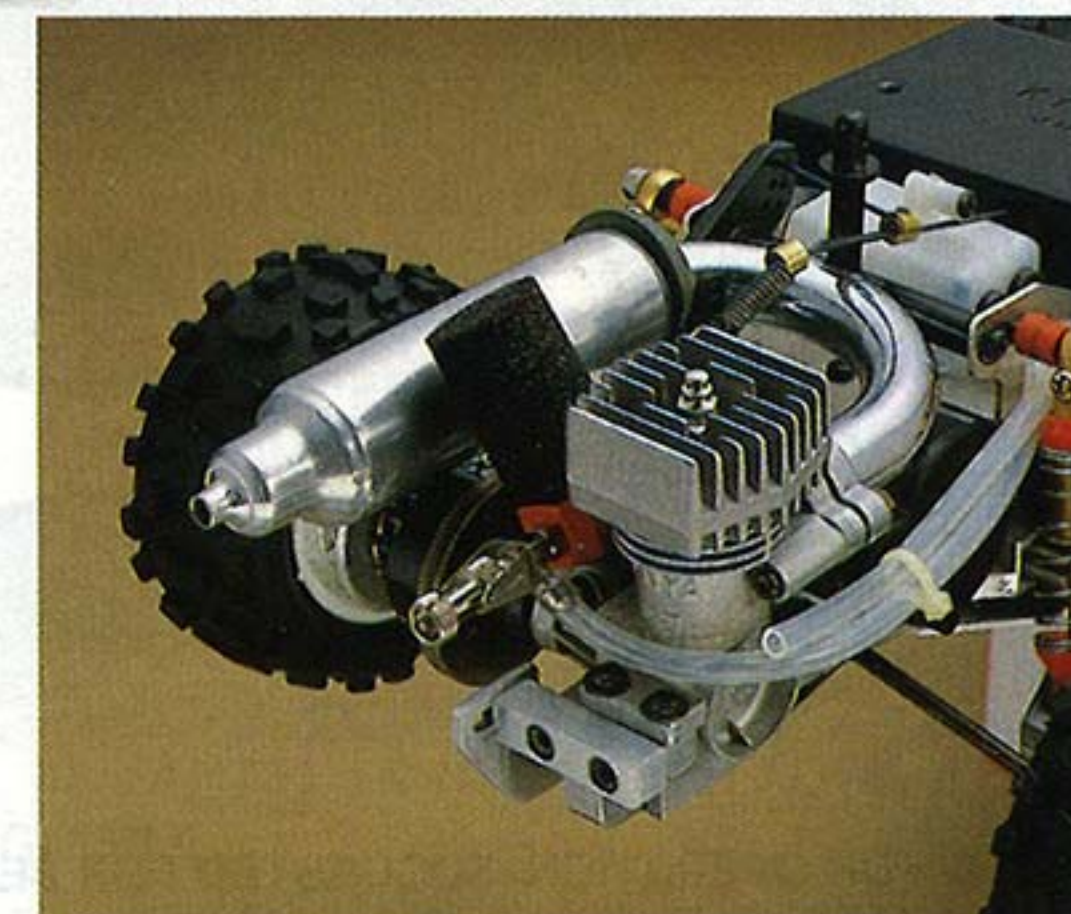

POWERFUL, EASY-STARTING ENYA QUICKY .09 ENGINE, MANIFOLD, AND EFFECTIVE MUFFLER ALL INCLUDED IN KIT.

MOTEUR PUISSANT ET FACILE À DÉMARRER ENYA QUICKY 09, ADAPTEUR ET SILENCIEUX EFFICACE, LE TOUT COMPRIS DANS LE KIT.



# CIRCUIT 1000 SERIES "STINGER 4WD," 10 ENGINE POWERED OFF-ROAD RACING BUGGY

1:10 SCALE  
NO.3041 • 19800



- ① ULTRA-LOW PROFILE PIN-SPIKE TIRES FOR DEPENDABLE TRACTION ON ANY SURFACE.
- ② EXTRA-LONG SUSPENSION TRAVEL (35mm F/R) TO ABSORB THE WORST BUMPS WITHOUT PROBLEMS.
- ③ FRONT DIFFERENTIAL PUTS DRIVING POWER INTO THE FRONT WHEELS-A FIRST IN .10 BUGGIES.
- ④ ANGLED STONE-GUARD PLATES DEFLECT ROCKS AND DIRT FROM RADIO EQUIPMENT AND ENGINE.
- ⑤ STRONG TEMPERED-STEEL DRIVE CHAIN IS LIGHT, RELIABLE AND EFFICIENT.
- ⑥ ENGINE MOUNTS ACCEPT ALMOST ANY .09-.11 GLOW ENGINE.
- ⑦ REAR DIFFERENTIAL FEATURES 3 BALL BEARINGS FOR LOW POWER LOSS, HIGH RELIABILITY.
- ⑧ MUFFLER (INCLUDED IN KIT) GIVES GOOD SILENCING WITH LOW POWER LOSS.
- ⑨ FOUR-WHEEL INDEPENDENT SUSPENSION WITH STRONG, LIGHT EX66 NYLON WHEELS DOUBLE WISHBONES.
- ⑩ STRONG, LIGHT, NYLON, WHEELS FOR MINIMUM UNSPRUNG WEIGHT.

1. PNEUS À POINTES PROFIL EXTRA BAS POUR UNE TRACTION OPTIMALE SUR N'IMPORTE QUELLE SURFACE.
2. SUSPENSION À LONGUE COURSE (35mm) EN VUE D'ABSORBER LES PIRES IRRÉGULARITÉS DE TERRAIN.
3. ROUES AV ENTRAINÉES PAR DIFFÉRENTIEL.
4. DÉFLECTEUR DE CAILLOUX ET DE POUSSIÈRE EN GUISE DE PROTECTION DE LA RADIO ET DU MOTEUR.
5. CHAÎNE EN ACIER TREMPÉ, EFFICACE, LÉGÈRE ET FIABLE.
6. BÂTI-MOTEUR ADAPTÉ À TOUS LES MOTEURS DE 1,5 À 2,1 Cm<sup>3</sup>.
7. DIFFÉRENTIEL AR AVEC 3 ROULEMENTS À BILLES, À HAUT RENDEMENT ET FIABLE.
8. SILENCIEUX (INCLUS) EFFICACE ET N'ABSORBANT QUE TRÈS PEU DE PUISSANCE.
9. QUATRE ROUES INDÉPENDANTES À BRAS DE SUSPENSION EN NYLON EX66 LÉGER ET RÉSIDANT.
10. JANTES LÉGÈRES EN NYLON RÉDUISANT LES MASSES NON SUSPENDUES.

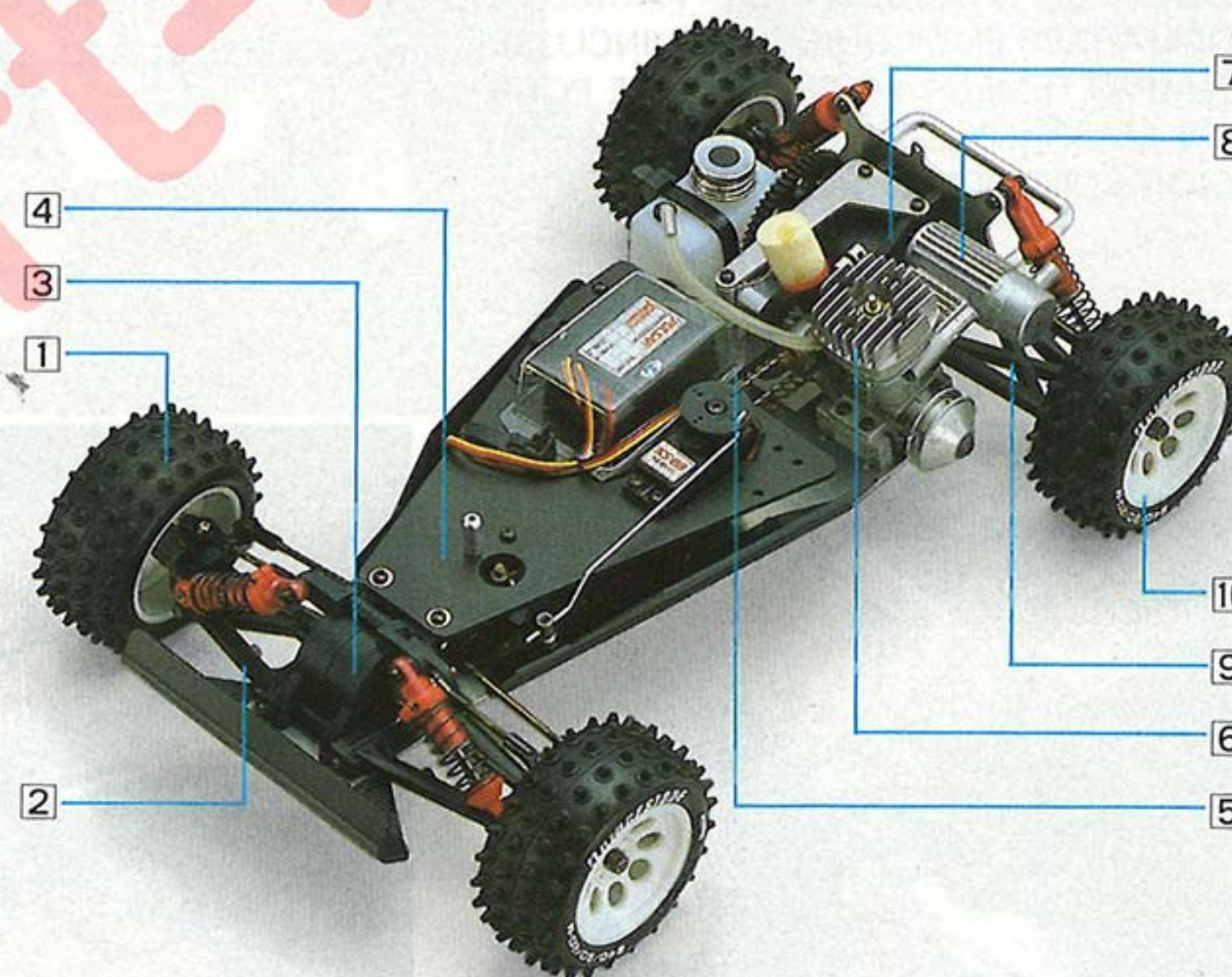
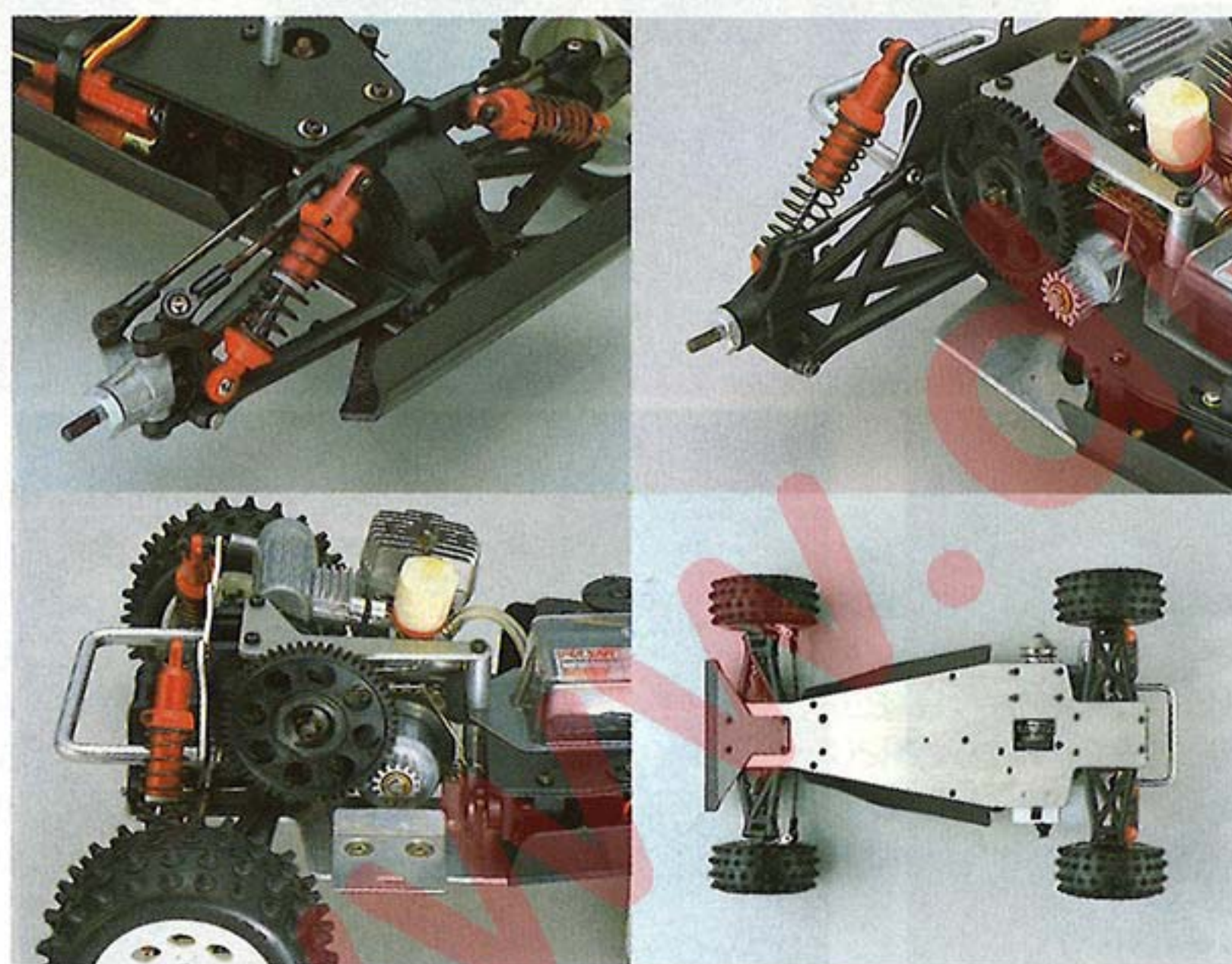

## REQUIRED FOR OPERATION/SUGGESTED FOR BEST APPEARANCE

● 2-CHANNEL RADIO CONTROL SET ● FUEL ● .09-.11 ENGINE ● POLYCA COLOR PAINT

### Technical Data

① Length/370mm(14.6in) ② Width/240mm(9.5in) ③ Height/110mm(4.3in) ④ Wheelbase/275mm(10.8in) ⑤ Ground Clearance/30mm(1.2in) ⑥ Front Track/200mm(7.9in) ⑦ Rear Track/205mm(8.1in) ⑧ Tires/(F)85 φ×37mm(3.3×1.5in);(R)85×φ37mm(3.3×1.5in) ⑨ Total Weight/1450g(50.9oz) ⑩ Engine/.09-.11 Class(Not included) ⑪ Radio/2-Channel(Not included)

### Technische Daten

① Longueur ② Largeur ③ Hauteur ④ Empattement ⑤ Garde au sol ⑥ Voie Avant ⑦ Voie Arrière ⑧ Roue ⑨ Poids Total ⑩ Moteur

## ACCESSOIRES REQUIS ET DÉCORATION SUGGÉRÉE

• ENSEMBLE RADIO 2 VOIES • CARBURANT • MOTEUR 1,5 À 2,1 Cm<sup>3</sup> • PEINTURES POLYCA •



# CIRCUIT 1000 SERIES "STINGER MK-II,"

## 10 ENGINE POWERED OFF-ROAD RACING BUGGY

1:10 SCALE  
NO.3042 • 21000



### NEW SOPHISTICATION IN .10 BUGGIES!

- ① ULTRA-LOW PROFILE PIN-SPIKE TIRES FOR DEPENDABLE TRACTION ON ANY SURFACE.
- ② MUFFLER (INCLUDED IN KIT) GIVES GOOD SILENCING WITH LOW POWER LOSS.
- ③ ENGINE MOUNTS ACCEPT ALMOST ANY .11 GLOW ENGINE.
- ④ STRONG TEMPERED-STEEL DRIVE BELT IS LIGHT, RELIABLE AND EFFICIENT.
- ⑤ OVERSIZE OIL-FILLED SHOCK ABSORBER.
- ⑥ NYLON "ROLL OVER" BUMPER.
- ⑦ REAR DIFFERENTIAL FEATURES 5 BALL BEARINGS FOR LOW POWER LOSS, HIGH RELIABILITY.
- ⑧ FOUR-WHEEL INDEPENDENT SUSPENSION WITH STRONG, LIGHT EX66 NYLON DOUBLE WISHBONES.
- ⑨ STRONG, LIGHT 17S ALUMINUM PANTYPE CHASSIS.
- ⑩ NYLON RADIO PLATE.
- ⑪ EX66 NYLON DOUBLE WISHBONES FRONT SUSPENSION.
- ⑫ STYLISH METALIZED NYLON WHEELS.

### NOUVELLE SOPHISTICATION EN BUGGYS 1/10e

1. PNEUS À POINTES PROFIL EXTRA BAS, ASSURANT LEUR TRACTION SUR TOUTES LES SURFACES.
2. SILENCIEUX (INCLUS) EFFICACE ET NE CAUSANT QU'UNE PERTE DE PUISSANCE INSIGNIFIANTE.
3. BÂTI-MOTEUR ADAPTÉ À TOUS LES MOTEURS DE 1,5 À 2,1 Cm<sup>3</sup>. MOTEUR INCLINÉ POUR UN MEILLEUR REFROIDISSEMENT.
4. CHAÎNE EN ACIER TREMPÉ, EFFICACE, LÉGÈRE ET FIABLE.
5. AMORTISSEURS HYDRAULIQUES SURDIMENSIONNÉS.
6. PARE-CHOC EN NYLON.
7. DIFFÉRENTIEL AR AVEC 5 ROUEMENTS À BILLES, RENDEMENT ÉLEVÉ ET FIABLE.
8. SUSPENSION INDÉPENDANTE AUX 4 ROUES ET BRAS EN NYLON LÉGER EX66.
9. CHÂSSIS EN ALUMINIUM 17S.
10. PLATINE RADIO EN NYLON.
11. SUSPENSION LONGUE COURSE (35mm) AFIN D'ABSORBER LES OBSTACLES ET D'ASSURER LA STABILITÉ DE TRAJECTOIRE.
12. JANTES EN NYLON MÉTALISÉ.

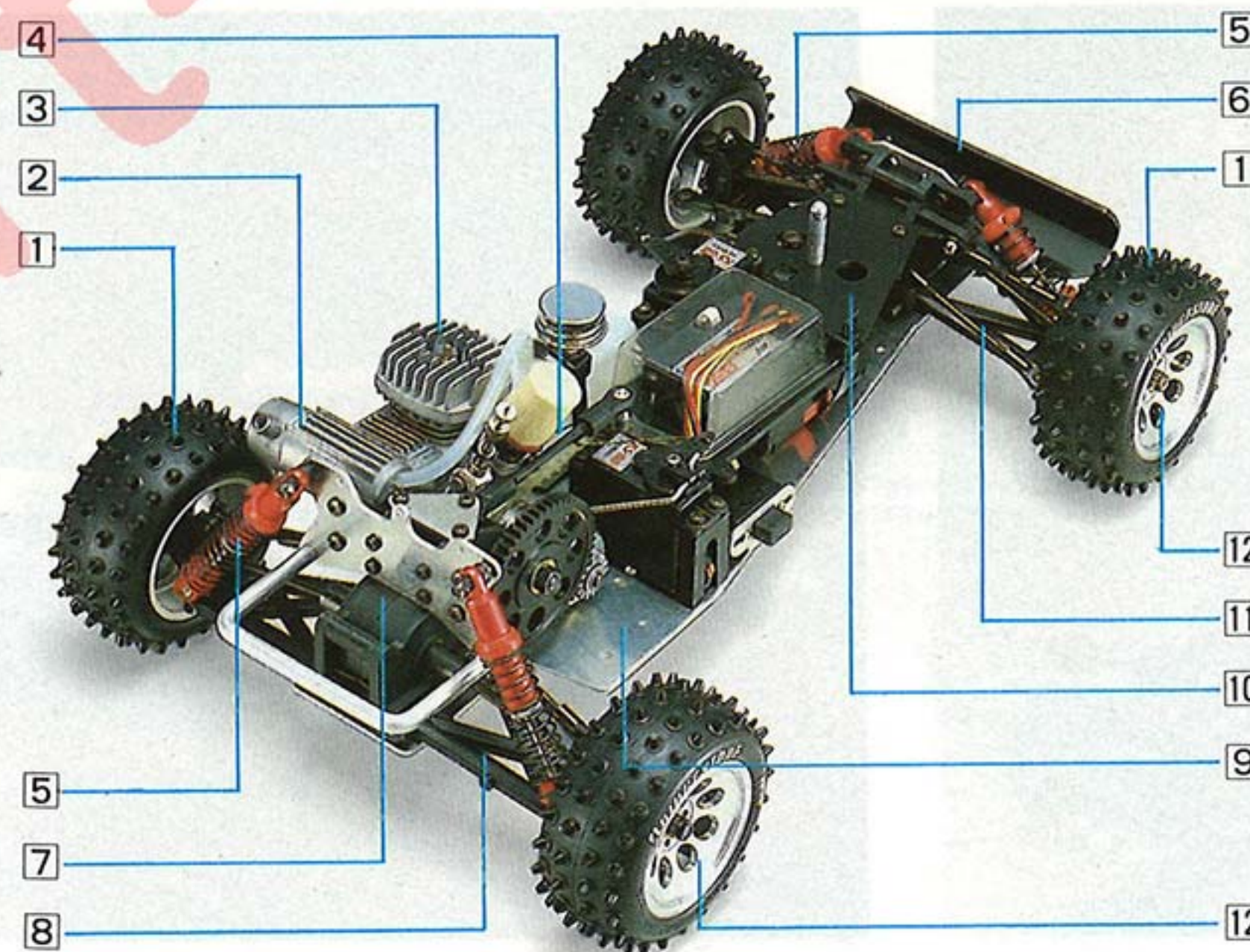
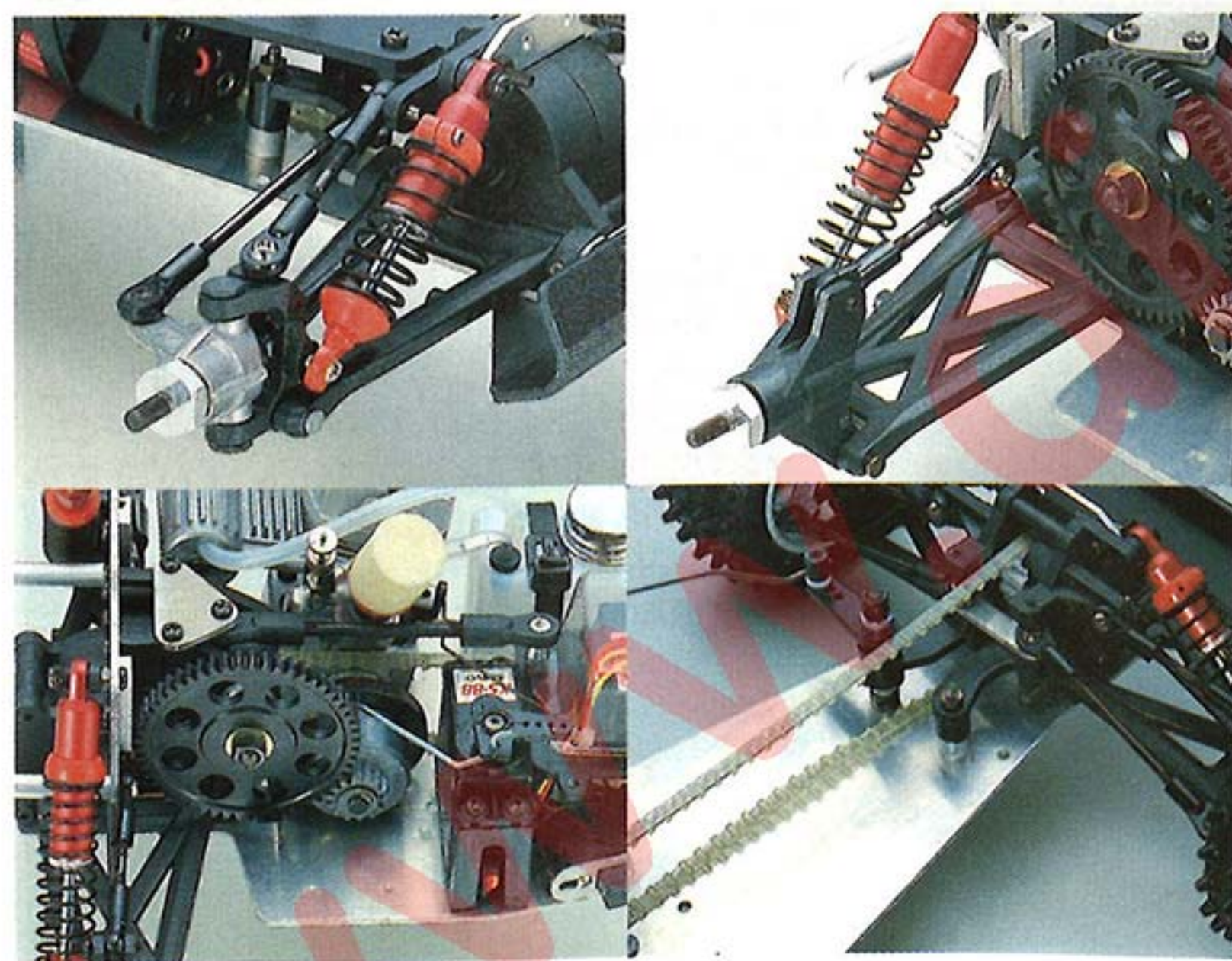

### REQUIRED FOR OPERATION/SUGGESTED FOR BEST APPEARANCE

- 2-CHANNEL RADIO CONTROL SET ● FUEL ● .09-11 ENGINE ● POLYCA COLOR PAINT ● MICRONLINE STRIPING TAPE

### Technical Data

- ① Length/370mm(14.6in) ② Width/240mm(9.5in) ③ Height/110mm(4.3in) ④ Wheelbase/275mm(10.8in) ⑤ Ground Clearance/30mm(1.2in) ⑥ Front Track/200mm(7.9in) ⑦ Rear Track/205mm(8in) ⑧ Tires/(F)85φ×37mm(3.3×1.5in);(R)85φ×37mm(3.3×1.5in) ⑨ Total Weight/1450g(50.9oz) ⑩ Engine/.11 Class(Not included) ⑪ Radio/2-Channel(Not included)

### Technische Daten

- ① Longueur ② Largeur ③ Hauteur ④ Empattement ⑤ Gard su sol ⑥ Voie Avant ⑦ Voie Arriere ⑧ Roue ⑨ Poids Total ⑩ Moteur

### ACCESSOIRES REQUIS ET DÉCORATION SUGGÉRÉE

- ENSEMBLE RADIO 2 VOIES ● CARBURANT ● MOTEUR 1,5 À 2,1 Cm<sup>3</sup> ● PEINTURES POLYCA ● FILETS ADHÉSIFS MICRONLINE ●



# CIRCUIT 1000 SERIES "ASSAULT,"

## 10 ENGINE POWERED OFF-ROAD RACER

1:10 SCALE  
NO.3095 • 28500



### ENGINE-POWER PERFORMANCE WITH ELECTRIC-POWER CONVENIENCE.

- WIDE BUMPER IS DOUBLE-PURPOSE, HOLDING GLOW-PLUG CELL.
- STRONG DIE-CAST ALUMINUM TRAILING-ARM SUSPENSION AND COILS-PRING/OIL-FILLED SHOCKS FOR TOP ROADHOLDING.
- RACING-DEVELOPED ALLOY-ALUMINUM LADDER-TYPE FRAME.
- PROTECTIVE RADIO BOX FOR RECEIVER AND BATTERIES.
- PUSH-BUTTON AUTO-PRIME FUEL TANK.
- FACTORY-ASSEMBLED GEAR BOX/DIFFERENTIAL UNIT.
- ZIP/PULL-CORD/ELECTRIC STARTER COMBINATION START SYSTEM.
- SPECIAL O.S. CZ ENGINE STARTS EASILY, REQUIRES NO ADJUSTMENTS.
- MUFFLER, FILTER, GLOW PLUG, STARTER CONE, ZIP AND ROPE INCLUDED.

### LA PERFORMANCE DU MOTEUR THERMIQUE AVEC LA FACILITÉ DU MOTEUR ÉLECTRIQUE

- PARE-CHOC À DOUBLE EMPLOI, CONTENANT UN LOGEMENT POUR BOUGIE.
- BONNE TENUE DE ROUTE GRÂCE À LA SUSPENSION À BRAS LONGITUDINAUX EN ALU INJECTÉ ET DES AMORTISSEURS HYDRAULIQUES À RESSORTS HÉLICOÏDAUX.
- CHÂSSIS DE COMPÉTITION EN ALLIAGE D'ALUMINIUM.
- LOGEMENT ÉTANCHE POUR LE RÉCEPTEUR ET LA BATTERIE.
- RÉSERVOIR À FERMETURE INSTANTANÉE.
- DIFFÉRENTIEL ASSEMBLÉ À L'USINE.
- SYSTÈME DE DÉMARRAGE PAR CORDE.
- MOTEUR SPÉCIAL O.S. CZ FACILE À DÉMARRER ET À RÉGLER.
- SILENCIEUX, FILTRE, BOUGIE, CÔNE DE DÉMARRAGE, POULIE ET CORDE COMPRIS.

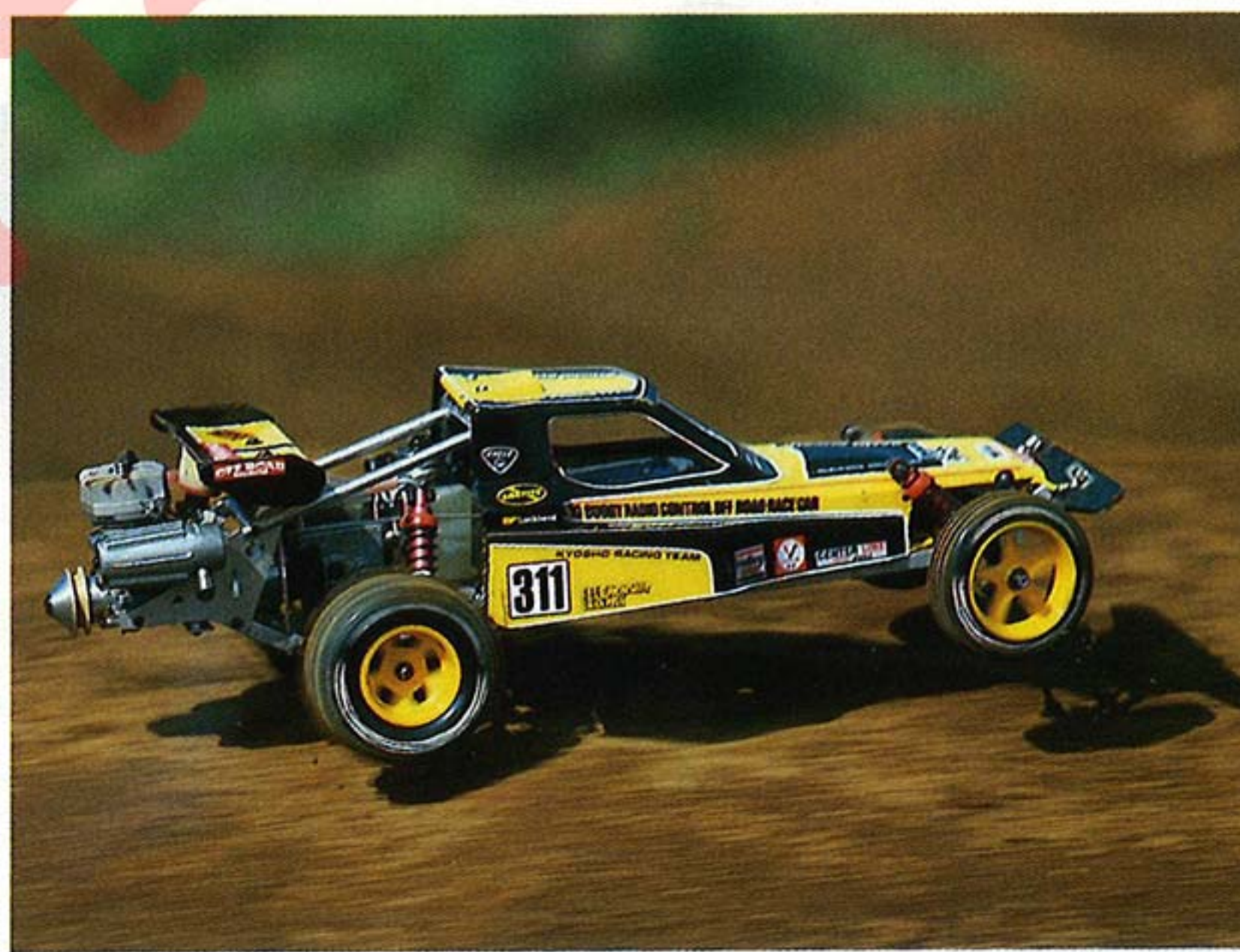

### REQUIRED FOR OPERATION/SUGGESTED FOR BEST APPEARANCE

- 2-CHANNEL RADIO CONTROL SET ● FUEL ● D-SIZE ALKALINE CELL ● POLYCA COLOR PAINT ● MICRONLINE STRIPING TAPE

### Technical Data

- ① Length/460mm(18.0in) ② Width/230mm(9.0in) ③ Height/135mm(5.3in) ④ Wheelbase/270mm(10.6in) ⑤ Ground Clearance/30mm(1.2in) ⑥ Front Track/182mm(7.2in) ⑦ Rear Track/186mm(7.3in) ⑧ Tires/(F)73φ×18mm(2.9×0.7in);(R)90φ×40mm(3.5×1.6in) ⑨ Total Weight/1480g(52oz) ⑩ Engine/O.S.CZ 12BB(Included) ⑪ Radio/2-Channel(Not included)

### Technische Daten

- ① Longueur ② Largeur ③ Hauteur ④ Empattement ⑤ Garde au sol ⑥ Voie Avant ⑦ Voie Arrière ⑧ Roue ⑨ Poids Total ⑩ Moteur

### ACCESSOIRES REQUIS ET DÉCORATION SUGGÉRÉE

- ENSEMBLE RADIO 2 VOIES • CARBURANT • PILES ALKALINE • PEINTURES POLYCA • FILETS ADHÉSIFS MICRONLINE •



## INTEGRA 4WD "VANNING,"

20 ENGINE POWERED 4-WHEEL DRIVE RACING BUGGY  
NO.3058 • 44800

## INTEGRA 4WD "PRESTO,"

20 ENGINE POWERED 4-WHEEL DRIVE RACING BUGGY  
NO.3059 • 43800

1:8 SCALE



THE WORLD TREND SETTER IS  
EVEN BETTER!

- ① LIGHTWEIGHT, RELIABLE CHAIN DRIVE SYSTEM.
- ② SIDEWAYS-MOUNTED MID-SHIP ENGINE FOR SIMPLE, LIGHT DRIVE SYSTEM, GOOD BALANCE.
- ③ GLASS-REINFORCED NYLON DOUBLE-WISHBONE FRONT SUSPENSION FOR STRENGTH, LIGHTNESS, HANDLING.
- ④ STRONG, LIGHT SQUARE-SECTION ALUMINUM ALLOY.
- ⑤ GR NYLON DOUBLE WISHBONE REAR SUSPENSION.
- ⑥ ABS MECHANISM COMPARTMENT FOR PROTECTION AGAINST WATER, DIRT.

LE CHEF DE FILE MONDIAL ENCORE  
AMÉLIORÉ!

1. TRANSMISSION PAR CHAÎNE, SYSTÈME EFFICACE ET LÉGER.
2. MOTEUR CENTRAL DÉCALÉ POUR UN PARFAIT ÉQUILIBRAGE.
3. SUSPENSION AV DOUBLES BRAS EN NYLON/FIBRE DE VERRE, SOLIDE, LÉGÈRE ET FIABLE.
4. CHÂSSIS RÉSIDANT EN TUBES D'ALUMINIUM CARRÉS.
5. BRAS DE SUSPENSION AR NYLON/FIBRE DE VERRE.
6. PROTECTION EN ABS CONTRE LA POUSSIÈRE ET L'HUMIDITÉ.

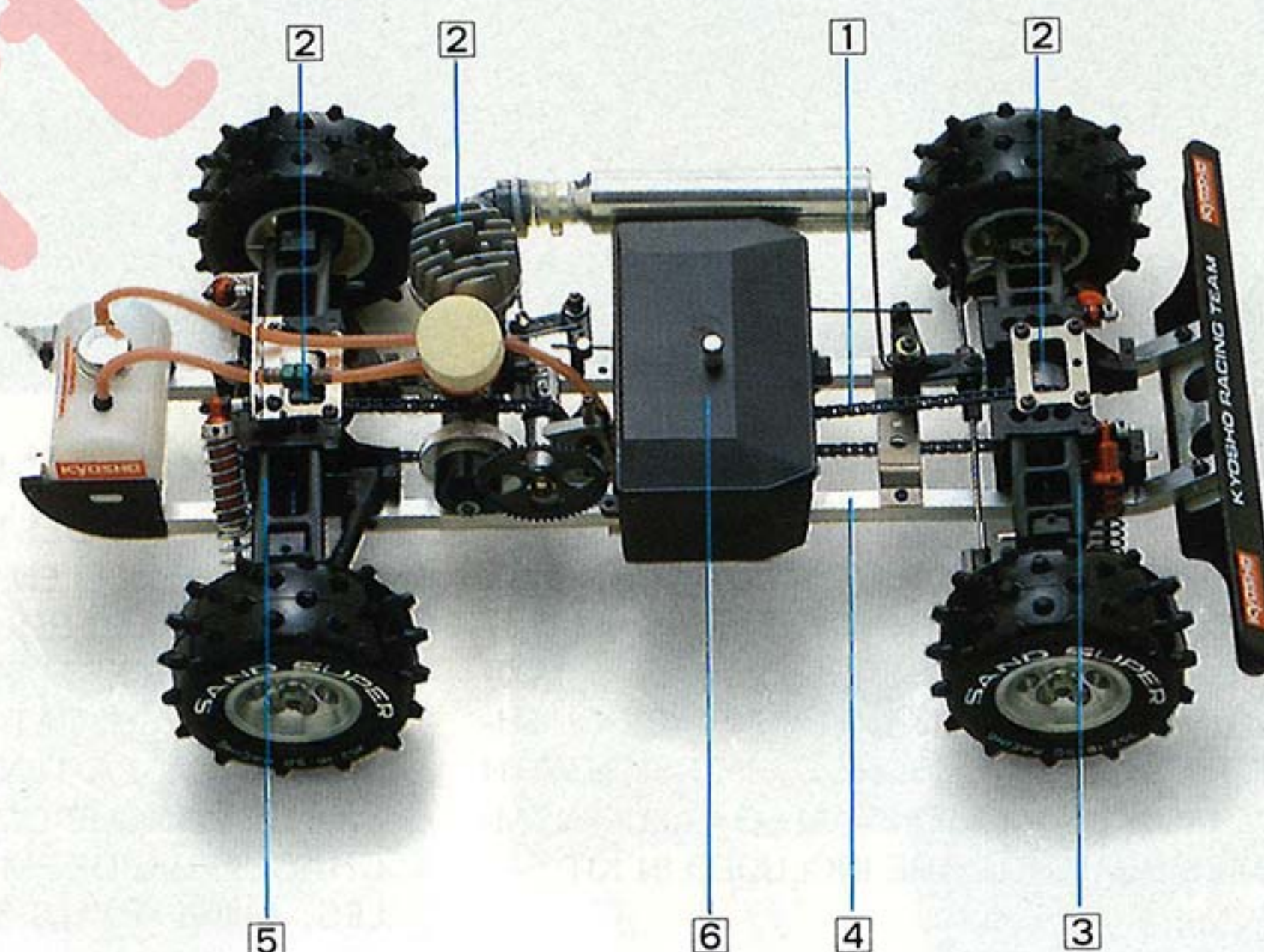

### REQUIRED FOR OPERATION

● 2-CHANNEL RADIO CONTROL SET ● .21 CLASS ENGINE AND MUFFLER ● ELECTRIC ENGINE STARTER AND BATTERY ● FUEL, GLOW PLUG BATTERY, ETC.

### Technical Data

① Length/520mm(20.5in) ② Width/285mm(11.2in) ③ Height/170mm(6.7in) ④ Wheelbase/314mm(12.7in) ⑤ Ground Clearance/43mm(1.7in) ⑥ Front Track/230mm(9.1in) ⑦ Rear Track/235mm(9.3in) ⑧ Tires/(F)105 φ × 46mm(4.1 × 1.8in) : (R)105 φ × 46mm(4.1 × 1.8in) ⑨ Total Weight/3100g(109.3oz) ⑩ Engine/.21 Class (Not included) ⑪ Radio/2-Channel(Not included)

### Technische Daten

① Longueur ② Largeur ③ Hauteur ④ Empattement ⑤ Garde au sol ⑥ Voie Avant ⑦ Voie Arrière ⑧ Roue ⑨ Poids Total ⑩ Moteur

### ACCESSOIRES REQUIS

● ENSEMBLE RADIO 2 VOIES ● MOTEUR 3,5 Cm<sup>3</sup> ET SILENCIEUX ● DÉMARREUR ÉLECTRIQUE ET BATTERIE. ● CARBURANT, BATTERIE POUR BOUGIE, ETC.





#### THE MOST ADVANCED .21-ENGINE OFF-ROADER ON THE MARKET!

BURNS IS DESTINED TO SET OFF-ROAD TRACKS ALIGHT WHEN IT COMES UP AGAINST THE COMPETITION! FOR EFFICIENCY AND RELIABILITY BURNS USES SHAFT DRIVE TO CONNECT THE ENGINE TO THE FRONT WHEELS. THREE EFFECTIVE GEAR-TYPE DIFFERENTIALS GET ALL THE ENGINE POWER ONTO THE TRACK VIA ALL FOUR WHEELS. THE RESULT? MAXIMUM TRACTION, ACCELERATION, AND CORNERING. ROADHOLDING ON EVEN THE ROUGHEST TRACKS IS SUPERB DUE TO THE LONGTRAVEL PARALLEL WISHBONE SUSPENSION WITH HIGH-QUALITY OIL-FILLED SHOCK ABSORBERS. CHASSIS IS A RIGID 17S ALLOY ALUMINUM-PLATE. SPECIAL MANIFOLD, MUFFLER, AND 18 BALL BEARINGS ARE INCLUDED IN KIT.

#### REQUIRED FOR OPERATION/SUGGESTED FOR BEST APPEARANCE

● ENGINE (.21 CLASS), FUEL STARTER, ETC. ● RADIO CONTROL SET (2-CHANNEL) ● POLYCA COLOR PAINT ● MICRONLINE STRIPPING TAPE

#### Technical Data

①Length/420mm(16.5in)②Width/300mm(11.8in)③Height/160mm(6.3in)④Wheelbase/320mm(12.6in)⑤Ground Clearance/45mm(1.8in)⑥Front Track/255mm(10.0in)⑦Rear Track/255mm(10.0in)⑧Tires/(F)116φ×42mm(4.6×1.9in);(R)116φ×48mm(4.6×1.7in)⑨Total Weight/3200g(7.1lb1oz)⑩Engine/.21-Class(Not included)⑪Radio/2-Channel(Not included)

#### Technische Daten

①Longueur②Largeur③Hauteur④Empattement⑤Garde au sol⑥Voie Avant⑦Voie Arriere⑧Roue⑨Poids Total⑩Moteur

#### LE BUGGY 3,5Cm<sup>3</sup> LE PLUS AVANCÉ ET LE PLUS PUISSANT DU MARCHÉ!

LE BURNS EST DESTINÉ À ENFLAMMER LES CIRCUITS LORSQU'IL EST CONFRONTÉ À LA CONCURRENCE! EN VUE DE L'EFFICACITÉ ET DE LA FIABILITÉ MAXIMALES LA TRANSMISSION VERS LES ROUES AV EST ASSURÉE PAR UN ARBRE RIGIDE. TOUTE LA PUISSANCE DU MOTEUR EST TRANSFÉRÉE VERS LES 4 ROUES GRÂCE AUX 3 DIFFÉRENTIELS, AVEC COMME RÉSULTAT UN MAXIMUM DE TRACTION, D'ACCÉLÉRATION ET DE NERVOUSITÉ EN VIRAGE. LA TENUE DE ROUTE ATTEINT UN NIVEAU INÉGALÉ GRÂCE À LA SUSPENSION À LONGUE COURSE PAR BRAS PARALLÈLES ET AMORTISSEURS HYDRAULIQUES. CHÂSSIS RIGIDE EMBOUTI EN ALUMINIUM 17S. LE KIT CONTIENT 18 ROULEMENTS À BILLES, AINSI QU'UN SILENCIEUX SPÉCIAL.

#### ACCESSOIRES REQUIS ET DÉCORATION SUGGÉRÉE

● MOTEUR 3,5Cm<sup>3</sup>, CARBURANT, DÉMARREUR, ETC. ● ENSEMBLE RADIO 2 VOIES ● PEINTURES POLYCA ● FILETS ADHÉSIFS MICRONLINE ●



# BURNS 4WD

## 21 ENGINE POWERED RACING BUGGY

1:8 SCALE  
NO.3096 • 49800



- ① NYLON "ROLL OVER" BUMPER.
- ② SPIKE-PATTERN TIRES FRONT/REAR.
- ③ WISHBONE/PARALLEL-ARM FRONT SUSPENSION WITH UNIVERSAL-JOINT HALF-SHAFT.
- ④ PRESSED 17S ALUMINIUM PAN-TYPE CHASSIS.
- ⑤ CUSTOM MUFFLER (INCLUDED IN KIT).
- ⑥ 21-CLASS ENGINE (NOT INCLUDED).
- ⑦ CUSTOM MANIFOLD (INCLUDED IN KIT).
- ⑧ WISHBONE/PARALLEL-ARM REAR SUSPENSION. FULLY ADJUSTABLE FRONT/REAR.
- ⑨ PRESSURE-TYPE OIL-FILLED SHOCK ABSORBERS FRONT/REAR.
- ⑩ METAL-GEAR TYPE DIFFERENTIAL FRONT/REAR.
- ⑪ DISC BRAKE.
- ⑫ TRANSFER CASE TO DIVIDE POWER BETWEEN FRONT AND REAR WHEELS.
- ⑬ SHAFT DRIVE TO FRONT/REAR WHEELS.

- 1. PARE-CHOC 'ROLL OVER' EN NYLON.
- 2. PNEUS AV ET AR À POINTES PROFIL BAS.
- 3. SUSPENSION AV À BRAS PARALLÈLES ET CARDANS HOMOCINÉTIQUE.
- 4. CHÂSSIS EMBOUTI EN ALUMINIUM 17S.
- 5. SILENCIEUX SPÉCIAL (INCLUS).
- 6. MOTEUR DE 3,5cm<sup>3</sup> (NON COMPRIS).
- 7. RACCORD DE SILENCIEUX SPÉCIAL.
- 8. SUSPENSION AR À BRAS PARALLÈLES ET CARDANS HOMOCINÉTIQUE. RÉGLABLE À L'ARRIÈRE COMME À L'AVANT.
- 9. AMORTISSEURS AV ET AR HYDRAULIQUES.
- 10. DIFFÉRENTIELS À ENGRENAGES.
- 11. FREIN À DISQUE.
- 12. BOÎTE DE RÉPARTITION DE LA TRACTION AV ET AR.
- 13. TRANSMISSION PAR ARBRE RIGIDE.

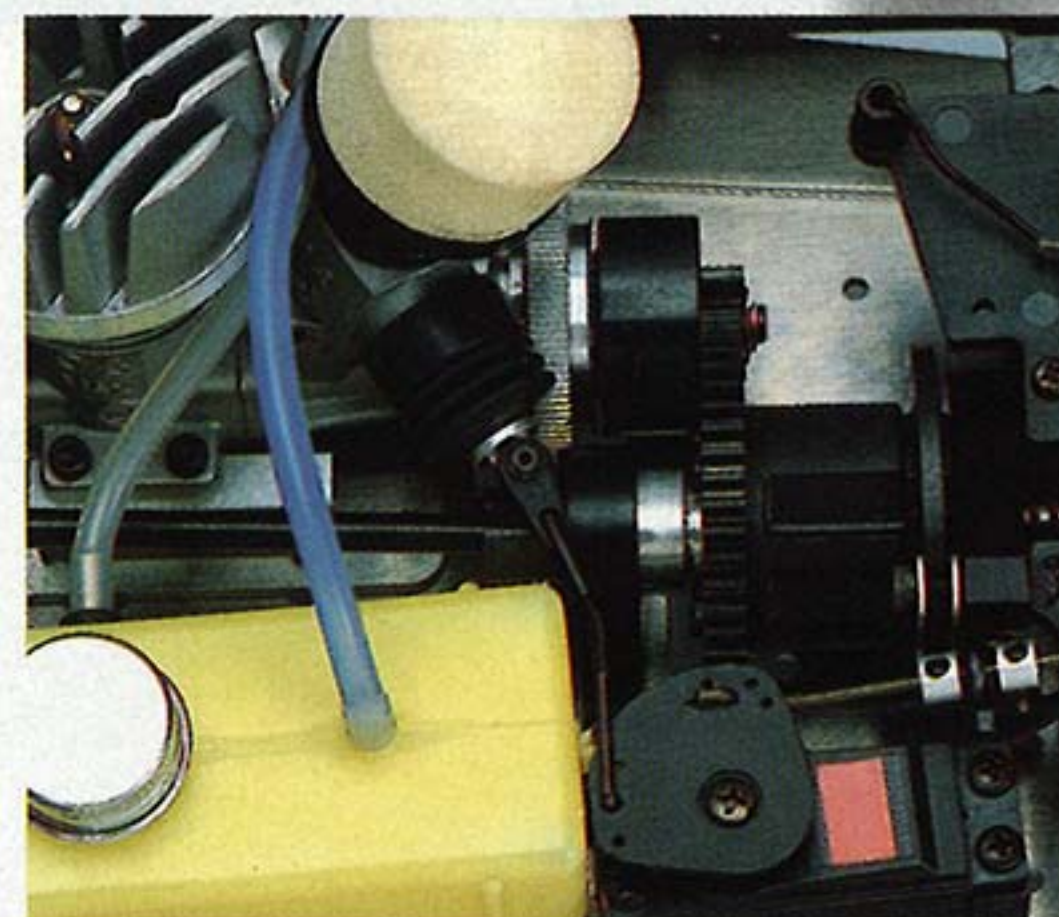
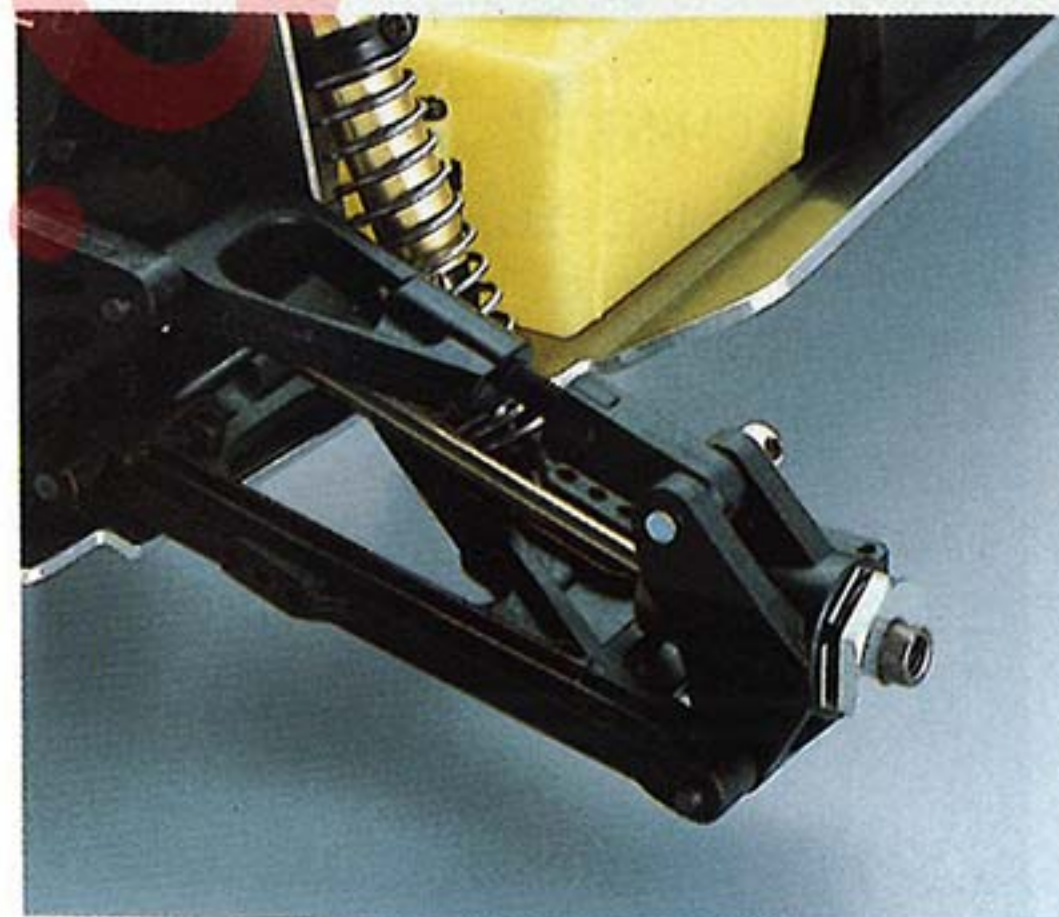
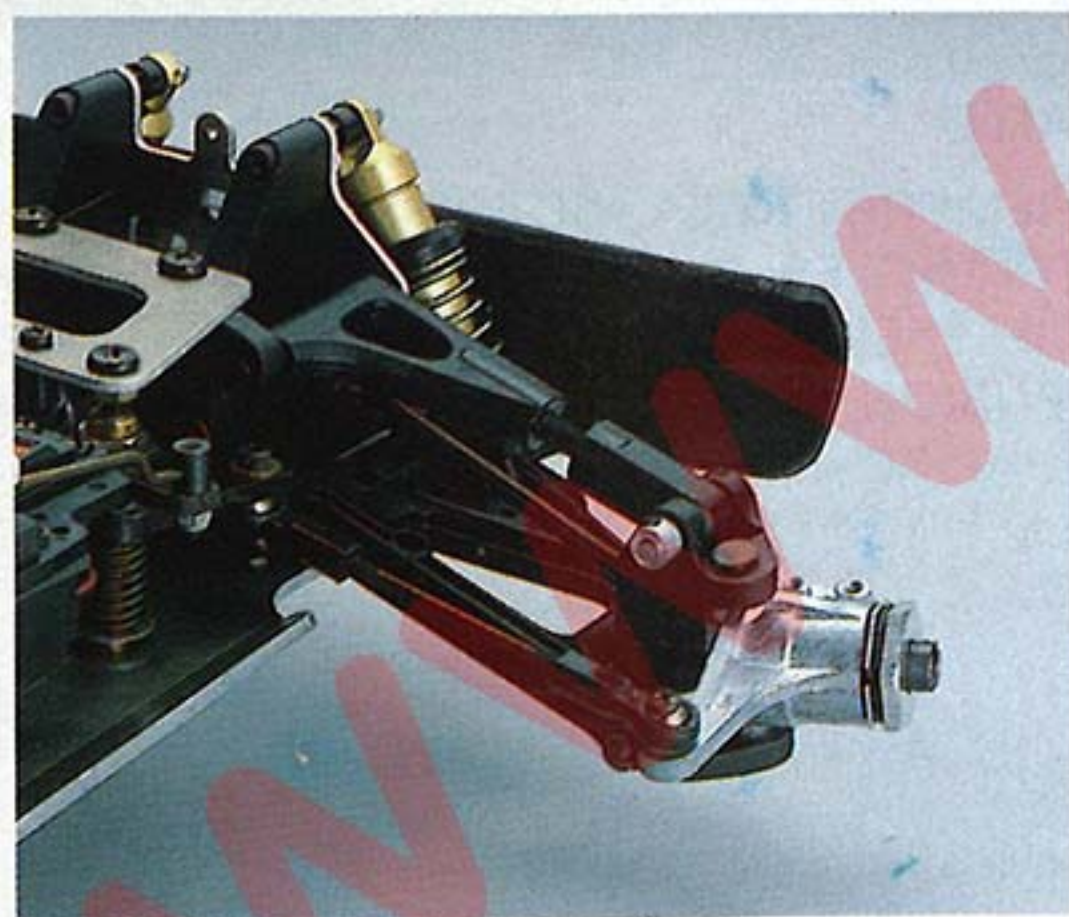
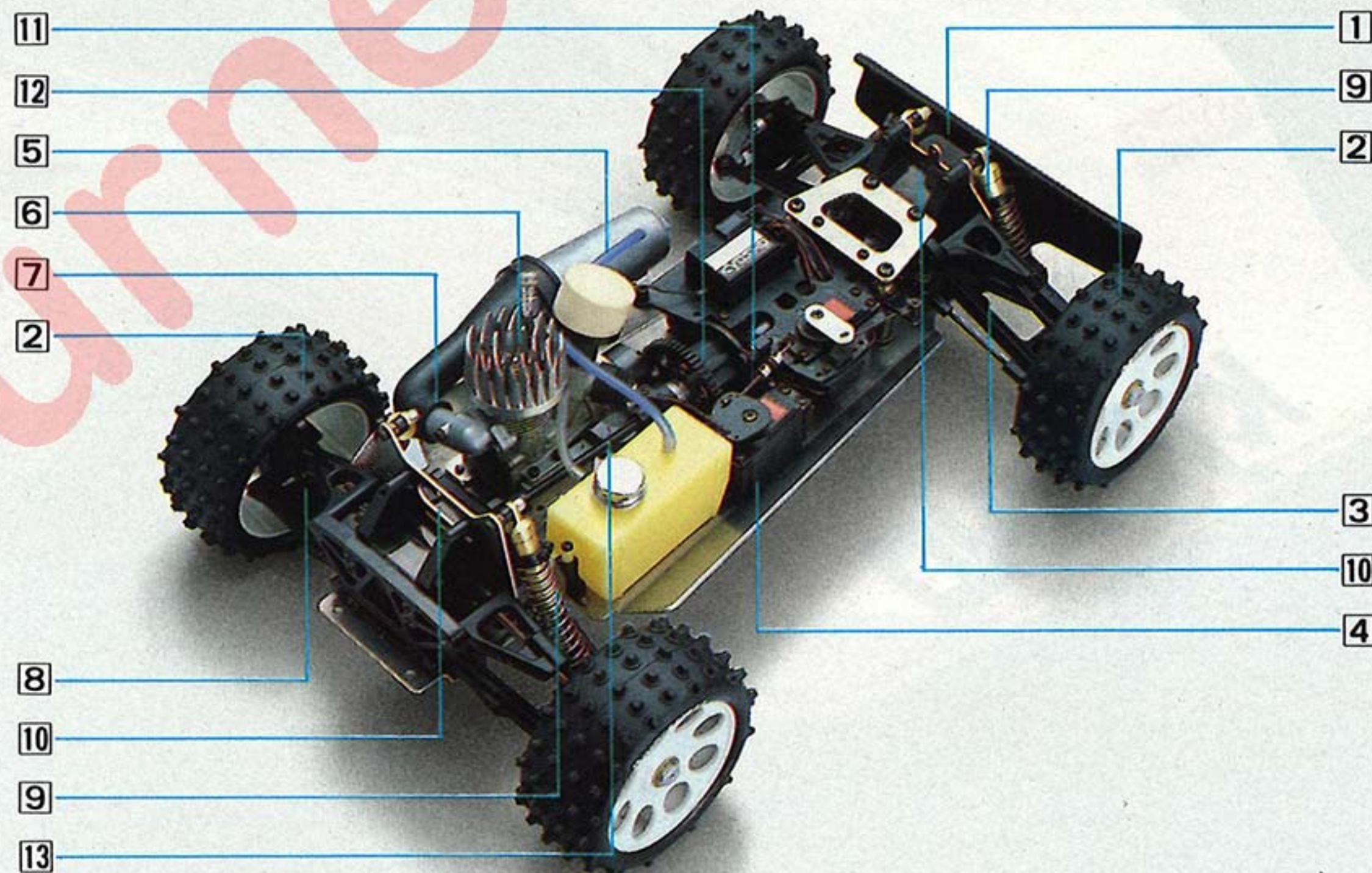

LONG-TRAVEL WISHBONE/PARALLEL-ARM FRONT/REAR SUSPENSION GOBBLES UP BUMPS. ASSURES DIRECTIONAL STABILITY. EFFECTIVE SHOCKS, STEEL DRIVESHAFTS FRONT/REAR.

SUSPENSION AV ET AR À BRAS PARALLÈLES LONGUE COURSE, QUI SUPPRIMENT TOUTES LES IRRÉGULARITÉS DE TERRAIN ET ASSURE LA STABILITÉ DE TRAJECTOIRE. AMORTISSEURS EFFICACES, CARDANS AV ET AR EN ACIER.

TRANSFER CASE SPLITS POWER TO FRONT AND REAR DRIVE WHEELS VIA DRIVE SHAFTS.

ENGRENAGE INTERMÉDIAIRE QUI RÉPARTISSENT LA TRACTION DES ROUES AV ET AR PAR L'INTERMÉDIAIRE D'ARBRES RIGIDES.



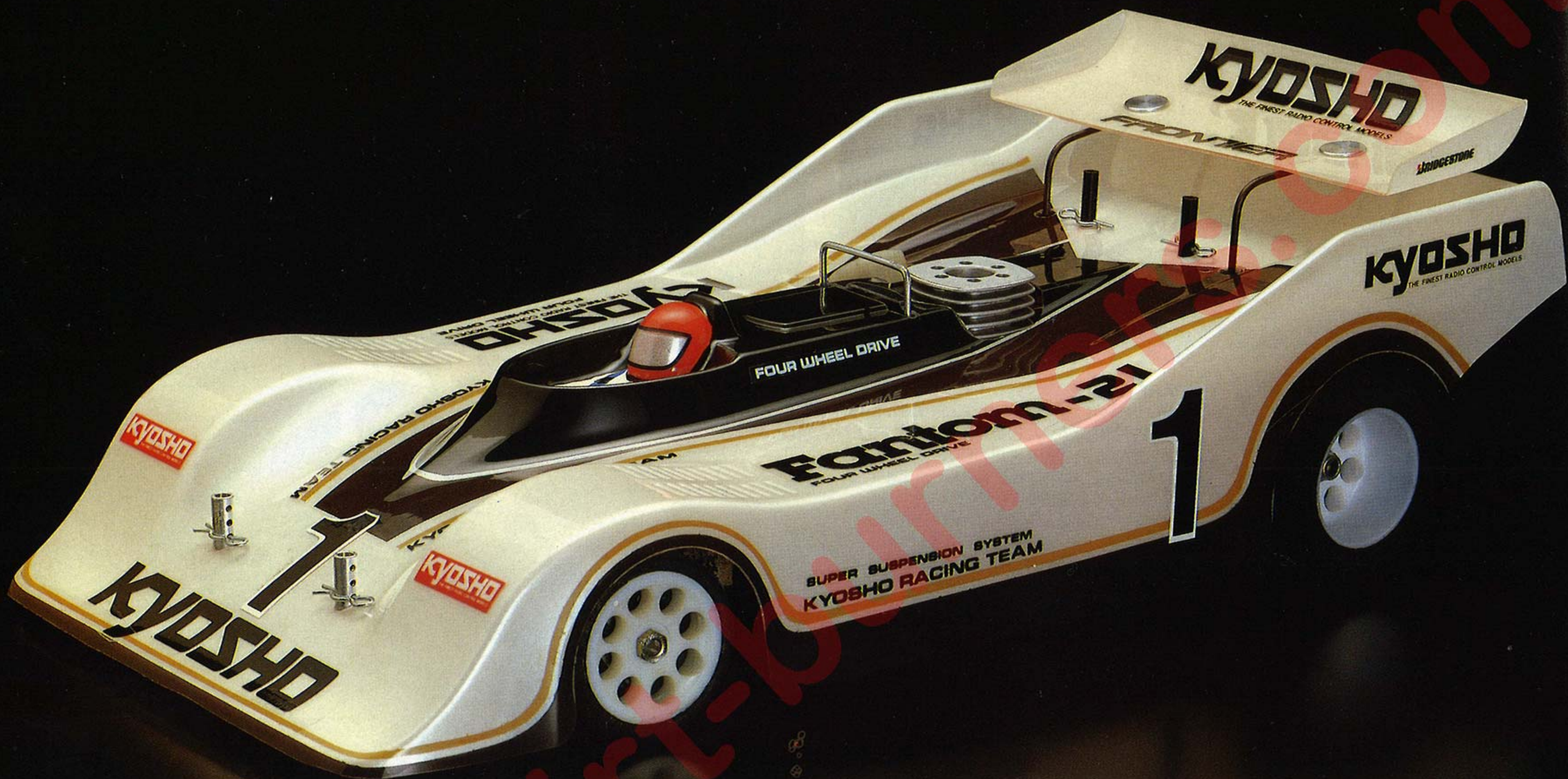

#### THE ALL-OUT COMPETITOR!

FIRST CHOICE FOR BEATING THE COMPETITION! FOUR-WHEEL DOUBLE-WISHBONE INDEPENDENT SUSPENSION. FOUR-WHEEL DRIVE VIA TWO DIFFERENTIALS AND LIGHT, RELIABLE TOOTHED DRIVE BELT. STIFF ALUMINUM ALLOY CHASSIS. STRONG GLASS-REINFORCED SUSPENSION PARTS. TOP-QUALITY OIL-FILLED SHOCK ABSORBERS. ANTI-DIVE, ANTI-ROLL FRONT SUSPENSION. MID-SHIPS/SIDEWINDER ENGINE POSITION FOR BEST BALANCE AND TOP POWER DELIVERY.

#### REQUIRED FOR OPERATION/SUGGESTED FOR BEST APPEARANCE

● 2-CHANNEL RADIO CONTROL SET ● FUEL, ETC. ● .21 ENGINE ● POLYCA COLOR PAINT

#### Technical Data

① Length/515mm(20.3in) ② Width/266mm(10.5in) ③ Height/130mm(5.1in) ④ Wheelbase/307mm(12.1in) ⑤ Ground Clearance/10mm(0.4in) ⑥ Front Track/210mm(8.3in) ⑦ Rear Track/198mm(7.8in) ⑧ Tires/(F)70φ×40mm(2.7×1.6in);(R)80φ×60mm(3.1×2.4in) ⑨ Total Weight/2650g(93.5oz) ⑩ Engine/.21 Class(Not included) ⑪ Radio/2-Channel(Not included)

#### Technische Daten

① Longueur ② Largeur ③ Hauteur ④ Empattement ⑤ Garde au sol ⑥ Voie Avant ⑦ Voie Arrière ⑧ Roue ⑨ Poids Total ⑩ Moteur

#### UNE MACHINE DE COMPÉTITION PARFAITE!

VOICI LE MEILLEUR CHOIX EN VUE DE REMPORTE LA VICTOIRE. QUATRE ROUES INDÉPENDANTES SUSPENDUES PAR TRIANGLES PARALLÈLES. QUATRE ROUES MOTRICES PAR L'INTERMÉDIAIRE DE 2 DIFFÉRENTIELS ET UNE COURROIE CRANTÉE. CHÂSSIS RIGIDE EN ALUMINIUM. SUSPENSION RENFORCÉE À LA FIBRE DE VERRE. AMORTISSEURS HYDRAULIQUES DE QUALITÉ. SUSPENSION AVANT STABILISÉE. MOTEUR CENTRAL EN VUE D'UNE MEILLEURE RÉPARTITION DES MASSES.

#### ACCESSOIRES REQUIS. DÉCORATION SUGGÉRÉE

• ENSEMBLE RADIO 2 VOIES • CARBURANT, ETC. • MOTEUR 3,5 Cm<sup>3</sup> • PEINTURE POLYCA •



# FANTOM 21-4iS

20 ENGINE POWERED RACING CAR

1:8 SCALE  
NO.3121 • 80000



- ① DOUBLE WISHBONES FRONT/REAR.
- ② LARGE OIL-FILLED SHOCKS (3).
- ③ EFFICIENT TOOTHED DRIVE BELT.
- ④ STIFF ALLOY ALUMINUM CHASSIS.
- ⑤ DIFFERENTIAL (FRONT/REAR).
- ⑥ ANTI-ROLL BAR.

- 1. DOUBLES TRIANGLES DE SUSPENSION AV ET AR.
- 2. TROIS AMORTISSEURS HYDRAULIQUES.
- 3. COURROIE CRANTÉE EFFICACE.
- 4. CHÂSSIS RIGIDE EN ALLIAGE D'ALUMINIUM.
- 5. DIFFÉRENTIEL AV ET AR.
- 6. BARRE STABILISATRICE.

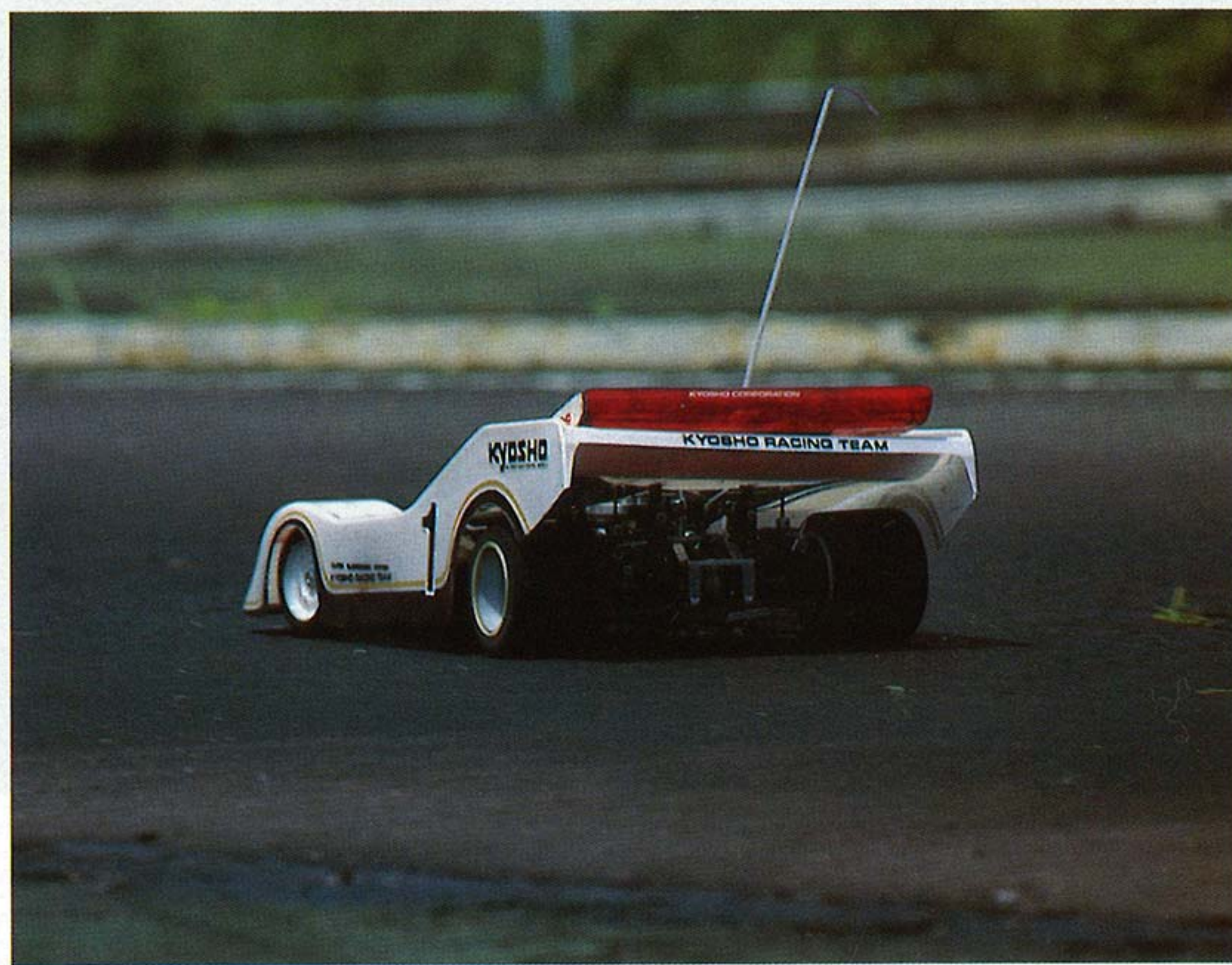
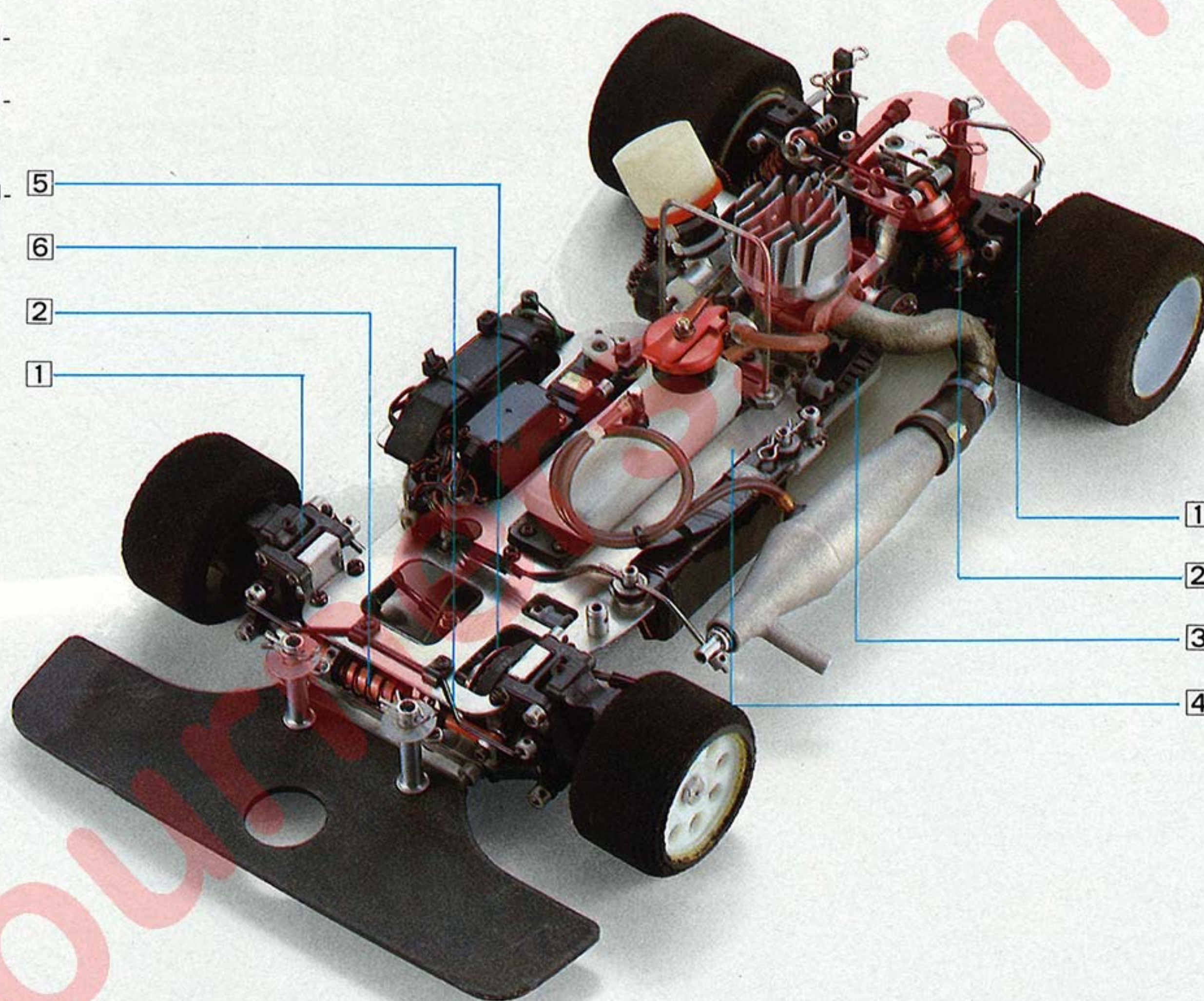



# POWER

■ BATTERIES ■ CHARGERS ■ MOTORS





# SUPER NICKEL-CADMIUM FAST-CHARGE BATTERIES



KYOSHO NICKEL-CADMIUM BATTERIES ARE HIGH-QUALITY POWER SOURCES FOR ALL APPLICATIONS CALLING FOR A 6, 7.2, OR 8.4V BATTERY PACK. NICKEL CADMIUM (NiCd) CELLS CAN TYPICALLY BE RECHARGED OVER 300 TIMES IF THE CELLS ARE NOT ABUSED (NOT OVERCHARGED OR OVERHEATED, AND IF THEY ARE REGULARLY CYCLED THROUGH THEIR FULL CAPACITY). ALL KYOSHO SUPER NiCd BATTERIES. CAN BE FAST CHARGED (15-20 MINUTES) USING A KYOSHO FAST CHARGER. THESE NiCd PACKS ARE DESIGNED TO POWER CARS, BUGGIES, BOATS AND AIRPLANES FOR FLEXIBILITY AND HEAT RESISTANCE. SAFELY AND POWERFULLY! ALL HAVE SILICONE RUBBER INSULATED WIRING.



■ **7.2V SPRINT BATTERY (7.2V-1200mAh) NO.2310**  
SPECIAL LOW-IMPEDANCE DESIGN CELLS (x6) FOR MINIMUM VOLTAGE DROP, MAXIMUM CURRENT AND POWER. THE BEST CHOICE FOR FAST SPRINT RACES. CAN BE FAST CHARGED. SILICONE RUBBER INSULATION. SPARE CONNECTOR INCLUDED. THE PREMIUM POWER SOURCE!

ELÉMENT SPÉCIAUX À BASSE RÉISTANCE INTERNE (x6) EN VUE D'UNE CHUTE DE TENSION MINIMALE, UN DÉBIT DE COURANT ET UNE PUISSANCE MAXIMUM. LE MEILLEUR CHOIX POUR LES COURSES DE VITESSE.

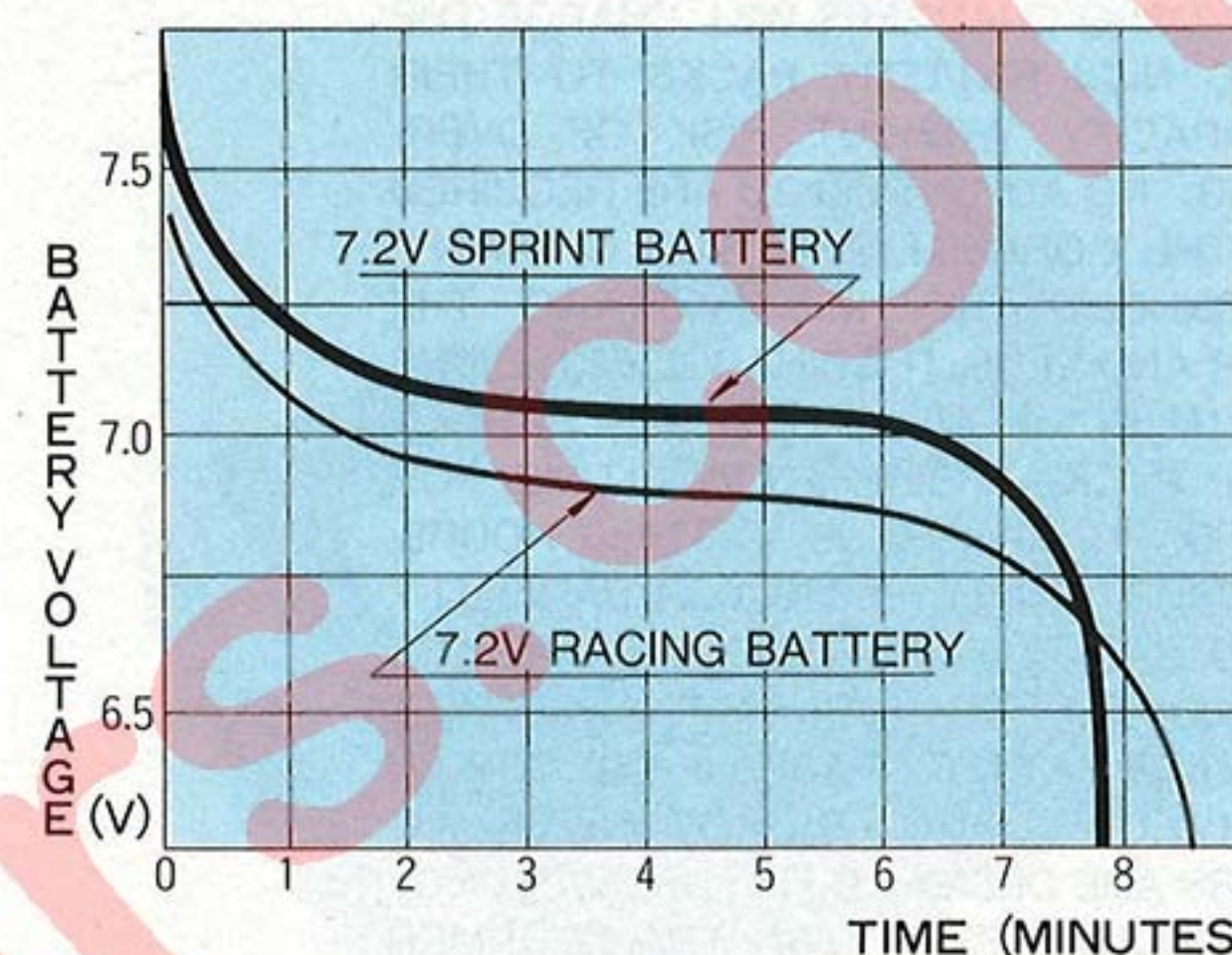

■ **8.4V TURBO RACING BATTERY (8.4V-1200mAh) NO.1932**  
THE MOST POWERFUL BATTERY FOR THE MOST POWERFUL CARS AND BUGGIES! CAN DELIVER MAXIMUM CURRENT FOR RACE-WINNING PERFORMANCE WITHOUT OVERHEATING OR DAMAGE.

LA BATTERIE LA PLUS PUISSANTE POUR LES MODÈLES LES PLUS PERFORMANTS! DÉBIT DE COURANT MAXIMAL SANS SURCHAUFFE NI DOMMAGE.



■ **7.2V RACING BATTERY (7.2V-1200mAh) NO.2218**  
FOR ALL APPLICATIONS REQUIRING 7.2V POWER. CAN SUPPLY HIGH CURRENT FOR RACING WITHOUT OVERHEATING. FOR SPORTS AND PERFORMANCE.

BATTERIE COURANTE POUR LES APPLICATIONS 7,2V. DÉBIT DE COURANT ÉLEVÉ POUR LA COMPÉTITION, SANS DANGER DE SURCHAUFFE. DESTINÉE AU SPORT ET À LA PERFORMANCE.



■ **6V-1200mAh NiCd BATTERY NO.2201**  
IDEAL FOR APPLICATIONS CALLING FOR HIGH CAPACITY BUT LOWER MAXIMUM POWER OUTPUT (6 VOLTS). IDEAL FOR MEDIUM SPEED BOATS AND CARS.

TYPE INDIQUÉ POUR LES GRANDES AUTONOMIES À PUISSANCE MODÉRÉE (6 VOLTS). IDÉAL POUR LES VOITURES ET LES BATEAUX À VITESSE MODÉRÉE.



■ **8.4V POWER BATTERY (8.4V-1200mAh) NO.2307**  
EXCELLENT GENERAL PURPOSE 8.4V NiCd POWER SOURCE. LONG LIFE, HIGH POWER FOR ALL SPORTS APPLICATIONS. (FOR RACING, USE 8.4V TURBO.)

EXCELLENTE SOURCE DE COURANT NiCad 8,4V POUR UTILISATION COURANTE. EXCELLENTE LONGÉVITÉ ET BONNE PUISSANCE POUR TOUTES UTILISATIONS DE SPORT (8,4V TURBO PLUS INDIQUÉES POUR LA COMPÉTITION).



■ **7.2V POWER BATTERY (7.2V-1200mAh) NO.2306**  
FOR ALL SPORTS APPLICATIONS REQUIRING 7.2V POWER. (USE "RACING" TYPE FOR COMPETITION.) FOR CARS, BOATS & SPORTS ELECTRIC AIRCRAFT.

POUR TOUTES APPLICATIONS 'SPORT' 7,2V EN VOITURE, BATEAU OU AVION (TYPE 'RACING' PLUS INDIQUÉES POUR LA COMPÉTITION).



■ **6V-450mAh NiCd BATTERY NO.2205**  
FOR USE AS EXTRA POWER SUPPLY FOR ELECTRIC AIRCRAFT MODELS USING 6V-450mAh NiCd PACKS. WITH ONE OR TWO PACKS, ALL-DAY NEARLY-CONSTANT FLYING IS POSSIBLE.

BATTERIE SUPPLÉMENTAIRE POUR LES AVIONS ÉLECTRIQUES À ALIMENTATION 6V-450mAh NiCad. AVEC UNE OU DEUX DE CES BATTERIES IL EST POSSIBLE DE VOLER TOUTE UNE JOURNÉE SANS INTERRUPTION.



# BATTERY CHARGERS (AC)



THESE KYOSHO CHARGERS WILL CHARGE THE DESIGNED NiCd BATTERY PACKS TO THEIR FULL CAPACITY WITHOUT RISK OF OVERCHARGING. NO ADJUSTMENTS ARE REQUIRED TO SET THE CORRECT CHARGING CURRENT: JUST CONNECT THE NiCd BATTERY PACK TO THE CHARGER AND PLUG THE CHARGER INTO THE WALL OUTLET. FOR A FULLY DISCHARGED BATTERY PACK, THE CHARGING TIME FOR STANDARD CHARGERS IS 14 TO 16 HOURS, AND PROPORTIONALLY LESS FOR PARTIALLY CHARGED PACKS. (CHARGING BEYOND THE TIME REQUIRED FOR 100% OF CHARGE WILL NOT DAMAGE BATTERY PACKS IF NOT FOR AN EXCESSIVELY LONG PERIOD.) NOTE: AC CHARGERS ARE DESIGNED FOR USE WITH 100V AC AND REQUIRE STEPDOWN TRANSFORMER FOR USE WITH 120, 220 OR 240V.



■ AC QUICK CHARGER [8.4V-1200mAh] NO.1931  
FOR FAST CHARGING 8.4V-1200mAh NiCd BATTERY PACKS, BOTH "RACING" AND "POWER" TYPES. FULL CHARGE IN 40 MINUTES OR LESS.

CHARGEUR RAPIDE POUR BATTERIES NiCad 8,4V-1200mAh DU TYPE 'POWER' OU 'RACING'. RECHARGE COMPLÈTE EN MOINS DE 40 MINUTES.



■ STANDARD CHARGER [8.4V-1200mAh] NO.2217  
FOR RECHARGING ALL 8.4V-1200mAh NiCd BATTERY PACKS, BOTH "RACING" AND "POWER" TYPES. CHARGES BATTERY TO PEAK POWER.

CHARGEUR UNIVERSEL POUR TOUTES LES BATTERIES NiCad 8,4V-1200mAh 'RACING' OU 'POWER'. RECHARGE MAXIMALE POUR UNE PUISSANCE DE POINTE.



■ AC QUICK CHARGER [7.2V-1200mAh] NO.2232  
FOR RECHARGING ALL 7.2V 1200mAh FAST-CHARGE NiCd PACKS USING AC POWER. FULLY DISCHARGED PACKS RECHARGE IN 40 MINUTES.

CHARGEUR RAPIDE SUR RÉSEAU POUR TOUTES LES BATTERIES 7,2V-1200mAh. CYCLE ACHÉVÉ EN MOINS DE 40 MINUTES POUR DES BATTERIES COMPLÈTEMENT DÉCHARGÉES.



■ STANDARD CHARGER [7.2V-1200mAh] NO.2221  
FOR RECHARGING ALL 7.2V 1200mAh NiCd BATTERY PACKS. (CAN BE USED WITH PACKS OF HIGHER CAPACITY FOR A LONGER CHARGING PERIOD.)

CHARGEUR POUR BATTERIES NiCad 7,2V-1200mAh, UTILISABLE POUR DES BATTERIES DE PLUS HAUTE CAPACITÉ MOYENNANT UN CYCLE PROLONGÉ.



# BATTERY CHARGERS (DC)



THESE CHARGERS ARE ALL DESIGNED TO RECHARGE QUICK-CHARGE NiCd BATTERY PACKS IN 15 MINUTES (FULLY DISCHARGED PACK; LESS IF PARTIALLY CHARGED) USING A STANDARD 12V CAR BATTERY AS POWER SOURCE. ALL USE A RELIABLE TIMER TO SHUT OFF CHARGING CURRENT AFTER THE REQUIRED TIME. SUPPLIED CONNECTORS ARE FOR KYOSHO NiCd BATTERY PACKS. BUT ANY FAST-CHARGE NiCd PACK CAN BE RECHARGED USING A SUITABLE CONNECTOR. THREE CHARGERS ARE FOR SPECIFIC TYPES OF NiCd PACKS (VOLTAGE AND CAPACITY)



## ■ 12V BATTERY ADAPTOR NO.2193

ALL DC CHARGER'S PLUG INTO THE CIGARETTE LIGHTER SOCKET OF A CAR. THIS ADAPTOR ALLOWS DIRECT CONNECTION TO THE BATTERY FOR CONVENIENCE AND LOWER POWER LOSS IN THE CAR WIRING.

LES CHARGEURS 12 VOLTS SE BRANCHENT SUR LA BATTERIE D'UNE AUTOMOBILE PAR L'INTERMÉDIAIRE DE L'ALLUME-CIGARES QUI EST DIRECTEMENT RACCORDÉ À LA BATTERIE.



## ■ DELTA PEAK CHARGER NO.1845

100% CHARGE IN 20 MINUTES (LESS FOR PARTIALLY CHARGED BATTERIES). BATTERY CHARGED TO PEAK CAPACITY. FOR 100 TO 4000 mAh 4.8 TO 8.4V NiCd PACKS. BUILT-IN AMMETER.

RECHARGE COMPLÈTE EN 20 MINUTES (MÊME MOINS SI LA BATTERIE N'EST QUE PARTIELLEMENT DÉCHARGÉE). DESTINÉ À TOUTES LES BATTERIES DE 100 À 4000 mAh ET DE 4,8 À 8,4V. AMPÈRE-MÈTRE INCORPORÉ.



## ■ MULTI-CHARGER II No.1849

CHARGES ANY 4.8-8.4V/250-1800mAh NiCd BATTERY FOR TIME PERIOD. CAN ALSO DISCHARGE AT FIXED RATE. COMPARTMENT FOR LEADS.

CET APPAREIL PEUT RECHARGER TOUS LES ACCUS NiCad DE 4,8 À 8,4V/250 À 1800mAh. IL PEUT ÉGALEMENT DÉCHARGER LES BATTERIES À RÉGIME CONSTANT. COMPREND UN LOGEMENT POUR LES CÂBLES.

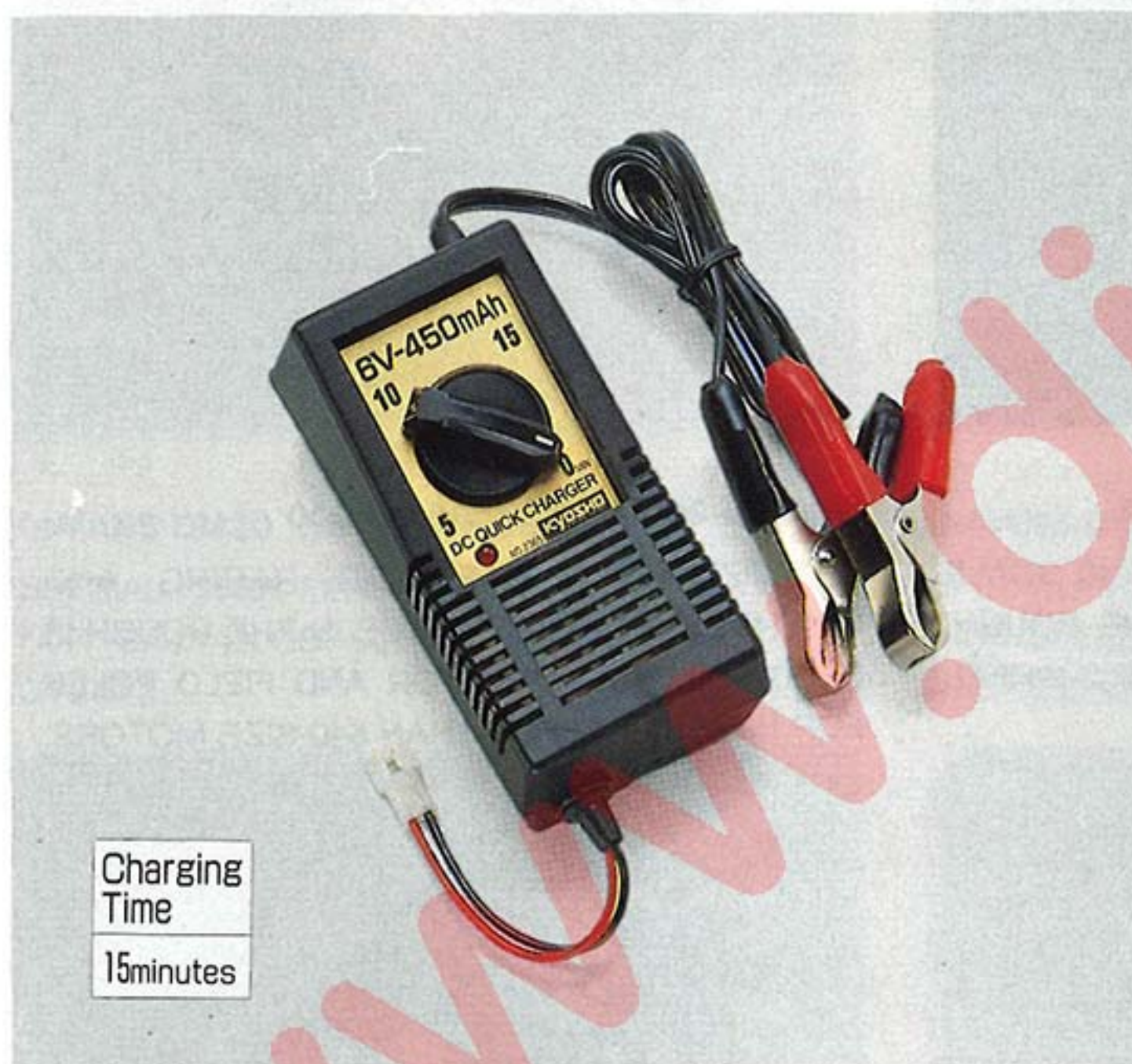

## ■ DC QUICK CHARGER (6V-450mAh) NO.2365

ALSO FOR QUICK-CHARGEABLE 6V-450mAh FLIGHT PACKS. FACTORY PRE-SET CURRENT. AUTO SHUT-OFF. USES 12V CAR BATTERY.

CHARGEUR POUR BATTERIES À CHARGE RAPIDE 6V-450mAh. RÉGLÉ À L'USINE. SHUT-OFF AUTOMATIQUE. ALIMENTATION: BATTERIE D'AUTOMOBILE 12V.



## ■ DC POWER QUICK CHARGER (8.4V-1200mAh) NO.2327

FACTORY PRE-SET CHARGING CURRENT. JUST SET THE REQUIRED CHARGING TIME (0 TO 15 MIN) AND CHARGER SWITCHES OFF AT END.

DÉBIT DE CHARGE RÉGLÉ À L'USINE, IL SUFFIT DE PROGRAMMER LA DURÉE DU CYCLE (0 À 15 MIN). EN FIN DE CHARGE, L'APPAREIL S'ARRÊTE AUTOMATIQUÉMENT.

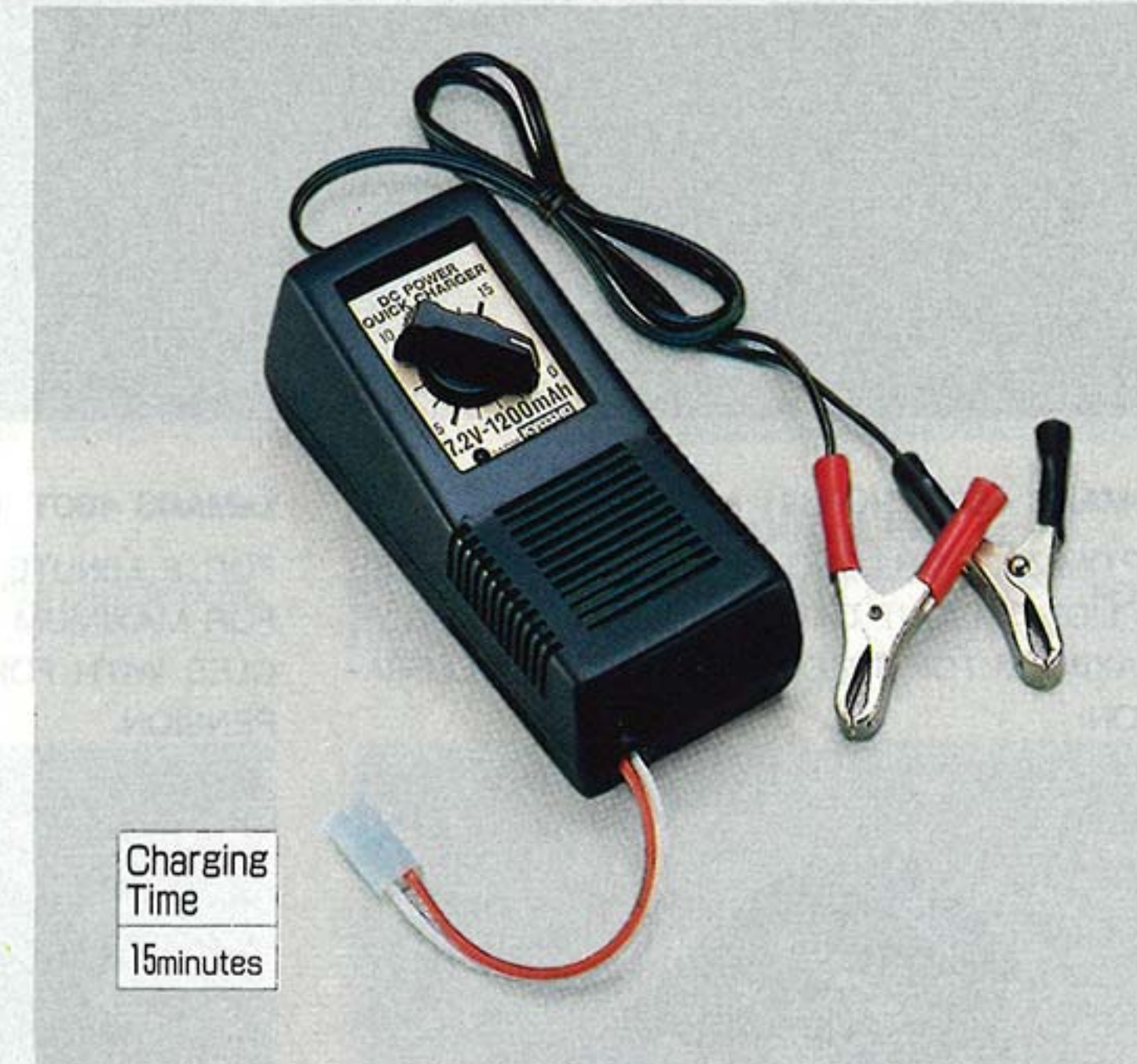

## ■ DC POWER QUICK CHARGER (7.2V -1200mAh) NO.2326

FOR FAST CHARGING ALL FAST-RECHARGEABLE 7.2V -1200mAh NiCd BATTERY PACKS, SUCH AS "RACING" OR "POWER" BATTERIES.

CHARGEUR RAPIDE POUR TOUTES LES BATTERIES DE 7,2V-1200mAh NiCad DU TYPE 'RACING' OU 'POWER'.



## RACING MOTOR "LeMANS," "SPA," HIGH-PERFORMANCE MOTORS FOR ELECTRIC MODELS



### LeMANS 480S NO.1891 ●4000

OPTIMIZED FOR LONG (UP TO 8 MINUTE) RACES IN LIGHTWEIGHT CARS (UNDER 900g) TO GIVE MAXIMUM TOP SPEED WITH GOOD ACCELERATION.



### LeMANS 480T NO.1892 ●4000

FOR 8 MINUTE RACES. HIGH-TORQUE TYPE FOR MAXIMUM ACCELERATIONS IN 4WD VEHICLES WITH FORE-WHEEL INDEPENDENT SUSPENSION.



### LeMANS 360 GOLD NO.1925 ●5800

THE TOP CHOICE FOR OFF-ROAD 1/10 SCALE BUGGY RACING AND POWER IN THE ROUGH. THE BEST CHOICE FOR REAR-MOTOR 2-WHEEL DRIVE TYPES.

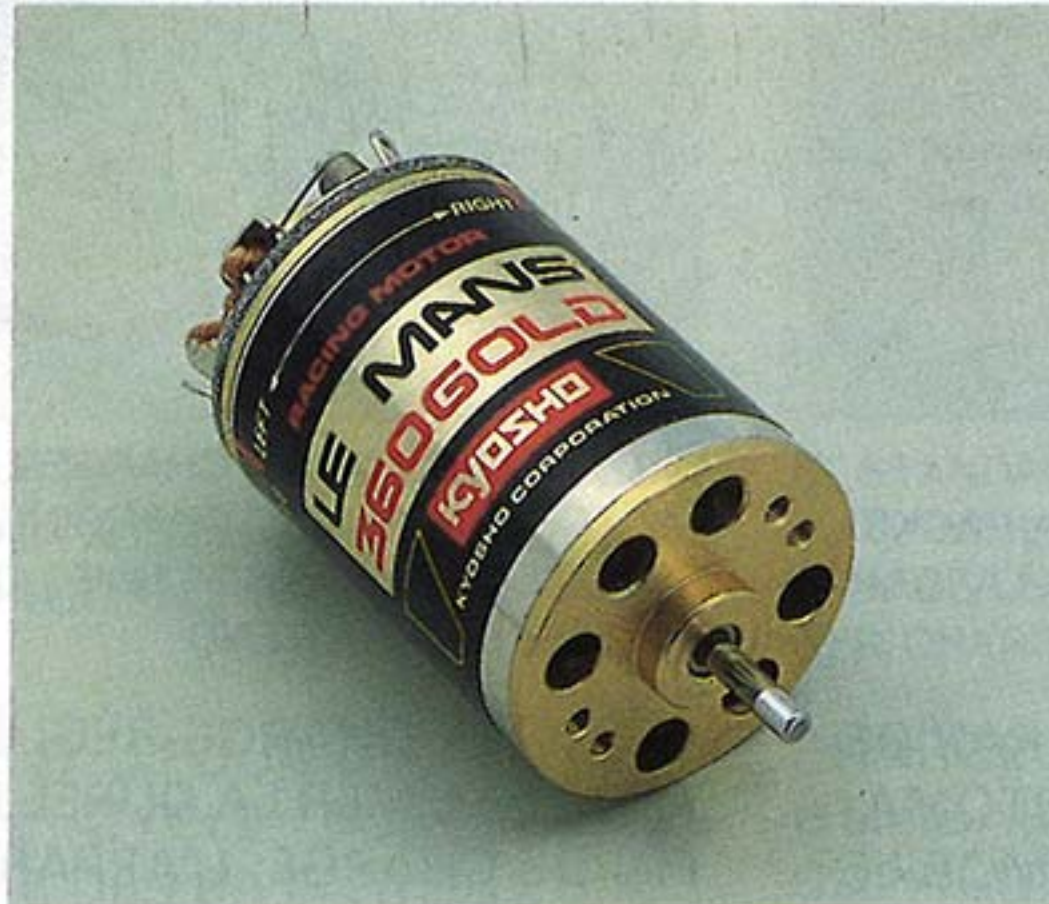

### LeMANS 480 GOLD NO.1897 ●5400

THE TOP CHOICE FOR 8-MINUTE RACING IN ROAD-RACING CARS AND 1/10 SCALE LIGHTWEIGHT MID-ENGINE BUGGIES. HIGHEST TOP SPEED, EXCELLENT ACCELERATION.



### LeMANS 360PT NO.1895 ●4500

OPTIMIZED FOR OFF-ROAD RACING AND WHERE HIGH PERFORMANCE IN THE ROUGH IS NEEDED. LONGER ROTOR AND FIELD POLES FOR HIGHER TORQUE THAN 540 SIZE MOTORS.







**LeMANS 360ST NO.1898 ●2000**

DESIGNED FOR OFF-ROAD BUGGIES WITH A LONGER ARMATURE AND FIELD POLES FOR HIGHER TORQUE. TIMING PRE-SET FOR MAXIMUM TORQUE.



**LeMANS 240SB NO.1924 ●5400**

THE TOP CHOICE FOR 4-MINUTE SPRINT RACES IN 1/12 SCALE ROAD-RACING CARS WHERE ALL-OUT MAXIMUM SPEED AND ACCELERATION ARE REQUIRED.

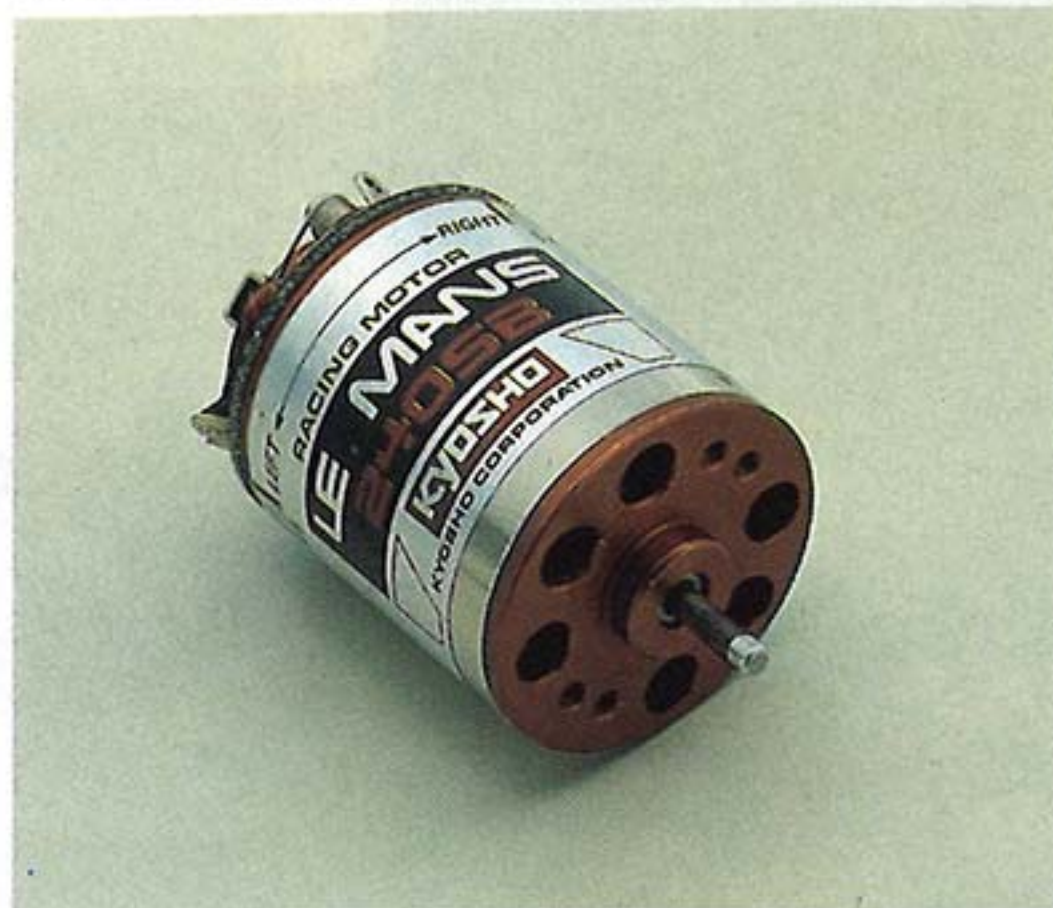

**LeMANS 240S NO.1893 ●4000**

OPTIMIZED FOR 4-MINUTE SPRINT RACES IN WHICH BOTH MAXIMUM ACCELERATION AND MAXIMUM TOP SPEED ARE NEEDED.



**LeMANS 240ST NO.1923**

FOR 4 MINUTE RACES. DESIGNED FOR OFF-ROAD BUGGIES WITH A LONGER ARMATURE AND FIELD POLES FOR HIGHER TORQUE.



**LeMANS 600E NO.1894 ●1980**

AN EXCELLENT CHOICE FOR POWERING MODEL ROAD CARS. HIGH POWER, QUICK ACCELERATION, AND MODERATE BATTERY DRAIN.



**LeMANS SPORTS H-240S NO.1926 ●3600**

HIGH-PERFORMANCE FOR SPRINT RACES. DESIGNED FOR OFF-ROADERS AND ROAD RACERS WHERE MAXIMUM SPEED WITH GOOD ACCELERATION WINS THE RACE.



**SPA-240WS W-1011 ●6800**

FOR 4-MINUTE SPRINT RACES WHERE THE HIGHEST POSSIBLE TOP SPEED AND ACCELERATION ARE REQUIRED.



**SPA-480WT W-1012 ●6800**

FOR 8-MINUTE RACES. HIGH-TORQUE TYPE FOR MAXIMUM ACCELERATION AND IN 4WD MACHINES THAT CAN USE ALL AVAILABLE TORQUE.



**LeMANS DM20 NO.1934 ●900**

SPECIAL HIGH-PERFORMANCE MINI MOTOR FOR BAJA-BUGS SERIES AND R/C MOTORCYCLES.

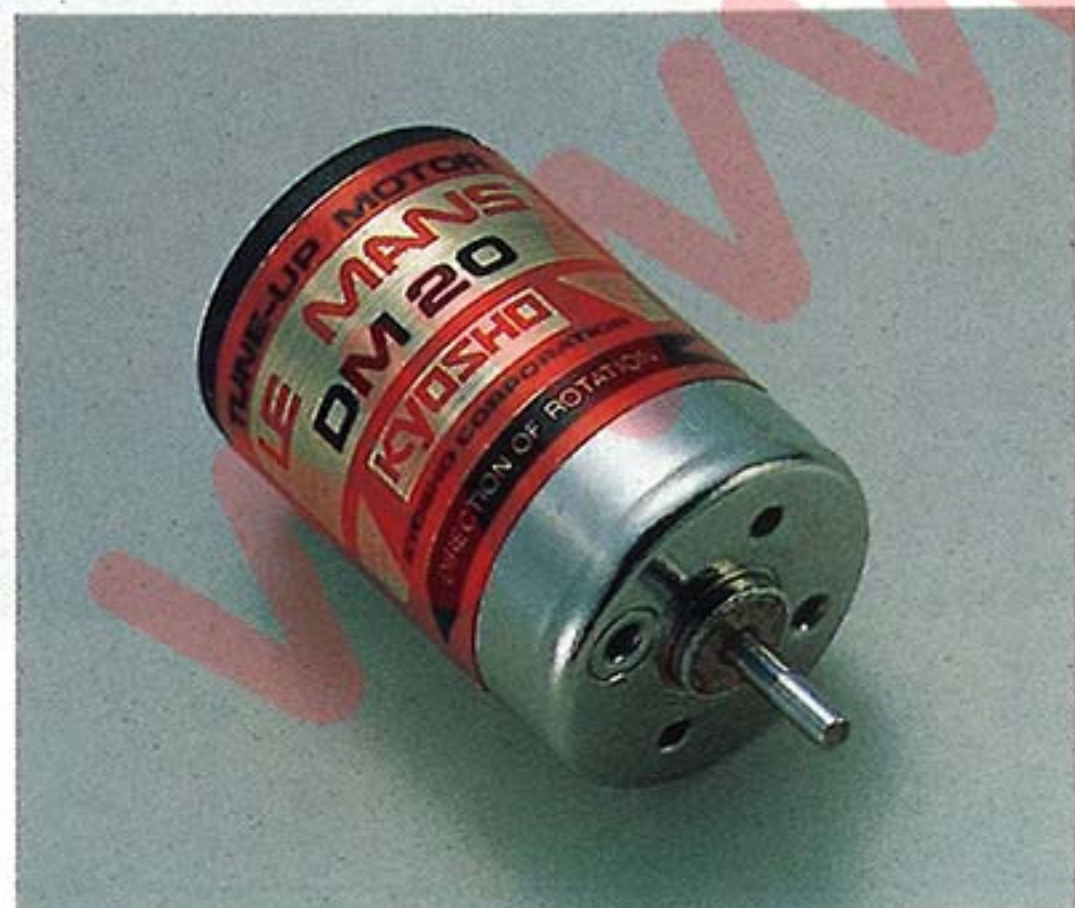

**LeMANS DMC20BB NO.1935 ●1500**

SPECIAL HIGH-PERFORMANCE MINI MOTOR. HIGH-SPEED TYPE FOR BAJA-BUGS SERIES AND R/C MOTORCYCLES.



**LeMANS AP29 NO.1929 ●1600**

HIGH-TORQUE, WIDE USE TYPE, SUITABLE FOR MODEL AIRPLANES AND BOATS.



**LeMANS AP29BB NO.1930 ●2500**

SPECIAL HIGH-PERFORMANCE MOTOR FOR AIRCRAFTS AND BOATS.





**MOTOR CHECKER NO.1896 • 6800**  
ELECTRIC MOTOR ANALYZER

**MOTOR BREAK-IN MACHINE**  
NO.1836 • 4800

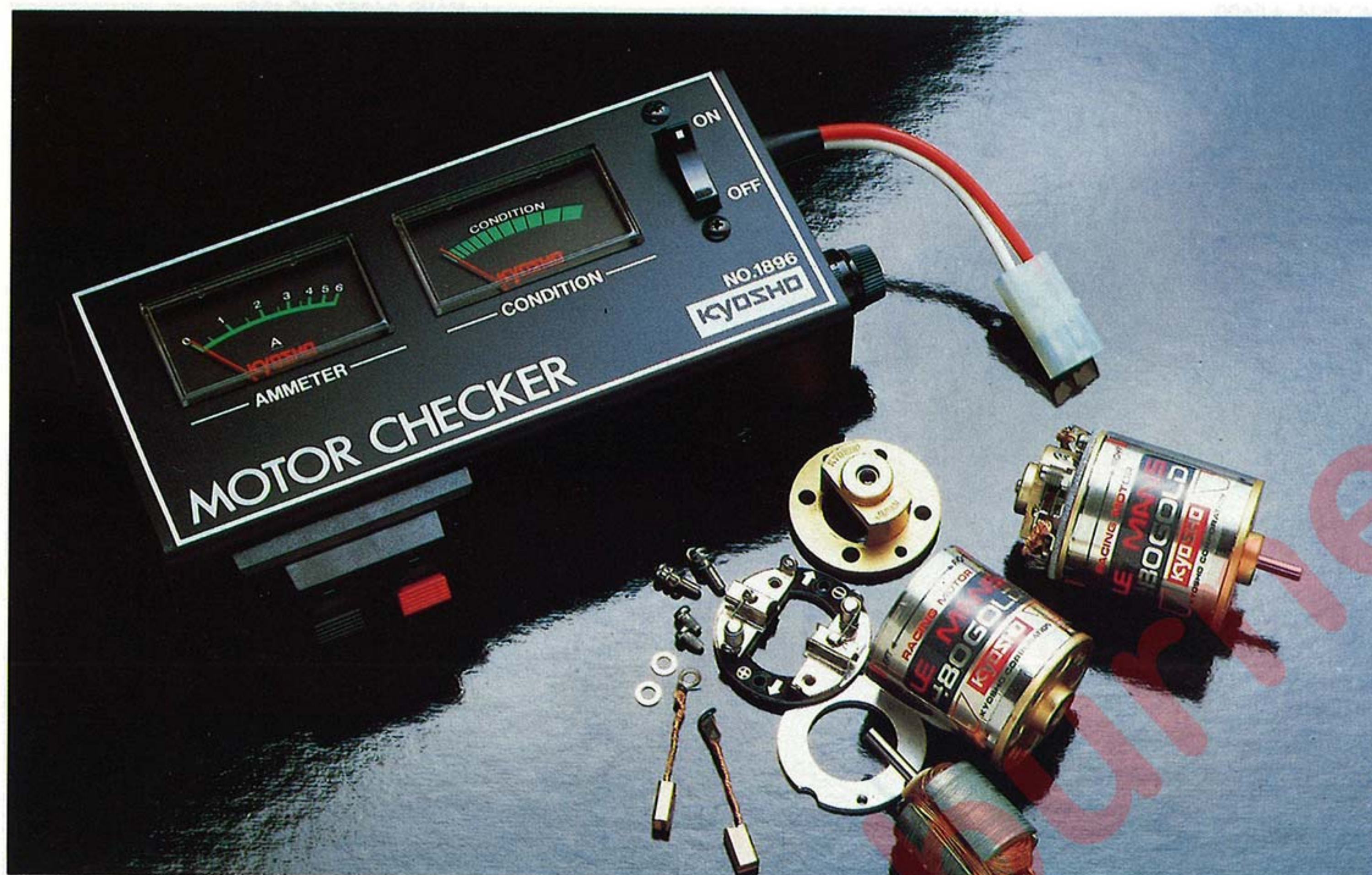

■ **MOTOR BREAK-IN MACHINE NO.1836 • 4800**

SUPPLIES LOW VOLTAGE FOR SLOW BREAK-IN RUNNING OF NEW MOTORS TO SHAPE BRUSH FACES. MAXIMIZES COMMUTATOR EFFICIENCY. USES 12V CAR BATTERY. WITH LEADS/AMMETER.

ALIMENTATION À TENSION RÉDUITE EN VUE DE RODER L'ENSEMBLE COLLECTEUR/BALAIS DES MOTEURS NEUFS POUR DES MEILLEURES PERFORMANCES. ALIMENTATION PAR BATTERIE D'AUTOMOBILE 12V. COMPREND LES CÂBLES DE RACCORDEMENT ET UN AMPÈRE-MÈTRE.

■ **MOTOR CHECKER NO.1896 • 6800**

DO YOU EVER WONDER IF THE MOTOR IN YOUR ELECTRIC COMPETITION CAR IS PERFORMING AT ITS BEST? THIS MOTOR ANALYZER A WORLD "FIRST" MAKES IT EASY TO CHECK BOTH THE TIMING ANGLE OF THE BRUSHES AND THE CONDITION OF THE BRUSHES AND COMMUTATOR.

VOUS VOULEZ VÉRIFIER SI VOTRE MOTEUR DE COMPÉTITION EST VRAIMENT BIEN RÉGLÉ? CET APPAREIL PERMET DE CONTRÔLER L'ANGLE DES BALAIS, ET L'ÉTAT DES BALAIS ET DU COLLECTEUR.

■ **RECOMMENDED LeMANS MOTORS/SPA MOTORS**

	LeMans											SPA	
	480GOLD	480S	480T	360GOLD	360PT	360ST	240SB	240S	600E	SPORTS H-240S	240WS	480WT	
BIG BRUTE	○	○	○	⊙	⊙	⊙	△	△	⊙	△	△	○	
RAIDER 2WD	○	○	○	⊙	⊙	⊙	⊙	⊙	○	⊙	⊙	○	
PEGASUS	○	○	○	⊙	⊙	⊙	△	△	○	△	△	○	
COSMO	○	○	○	⊙	⊙	⊙	△	△	○	△	△	○	
ICARUS	○	○	○	⊙	⊙	⊙	△	△	○	△	△	○	
ULTIMA	○	○	○	⊙	⊙	⊙	⊙	⊙	○	⊙	⊙	○	
SHADOW 4WD	○	○	○	⊙	⊙	⊙	⊙	⊙	○	⊙	⊙	○	
ROCKY 4WD	○	○	○	⊙	⊙	⊙	⊙	⊙	○	⊙	⊙	○	
OPTIMA	○	○	○	⊙	⊙	⊙	⊙	⊙	○	⊙	⊙	○	
JAVELIN	○	○	○	⊙	⊙	⊙	⊙	⊙	○	⊙	⊙	○	
OPTIMA PRO	○	○	○	⊙	⊙	⊙	⊙	⊙	○	⊙	⊙	○	
OPTIMA MID	○	○	○	⊙	⊙	⊙	⊙	⊙	○	⊙	⊙	○	
TURBO OPTIMA MID	○	○	○	⊙	⊙	⊙	⊙	⊙	○	⊙	⊙	○	
GALLOP MKII	○	○	○	⊙	⊙	⊙	△	△	○	△	△	○	
TURBO ROCKY	○	○	○	⊙	⊙	⊙	⊙	⊙	○	⊙	⊙	○	
TURBO OPTIMA	○	○	○	⊙	⊙	⊙	⊙	⊙	○	⊙	⊙	○	
SALUTE	○	○	○	⊙	⊙	⊙	⊙	⊙	○	⊙	⊙	○	
HONDA CRX	○	○	○	×	×	×	△	△	⊙	△	△	○	
PEUGEOT 205	○	○	○	×	×	×	△	△	⊙	△	△	○	
PLAZMA MKIII	○	○	○	×	×	×	△	△	⊙	△	△	○	
FANTOM EP EXT	○	○	○	×	×	×	△	△	○	△	△	○	
FLASH EP	○	○	○	△	△	△	⊙	⊙	△	⊙	⊙	○	
VALENCIA 1800	○	○	○	×	×	×	⊙	⊙	△	⊙	⊙	○	
ETUDE 1200	○	○	○	⊙	⊙	⊙	⊙	⊙	△	⊙	⊙	○	
DUET 1200	○	○	○	⊙	⊙	⊙	⊙	⊙	△	⊙	⊙	○	
EP ZERO FIGHTER	○	○	○	○	○	○	⊙	⊙	△	⊙	⊙	○	

MARKS: ⊙=RECOMMENDED ○=SUITABLE △=NOT RECOMMENDED ×=WILL NOT FIT



# Option House



# SPECIAL PARTS



# OPTION HOUSE

## SPECIAL PARTS FOR RADIO CONTROLLED MODELS



W-0101 MOTOR GUARD



W-0102 SIDE GUARD



W-0103 GOLD PLATE SET

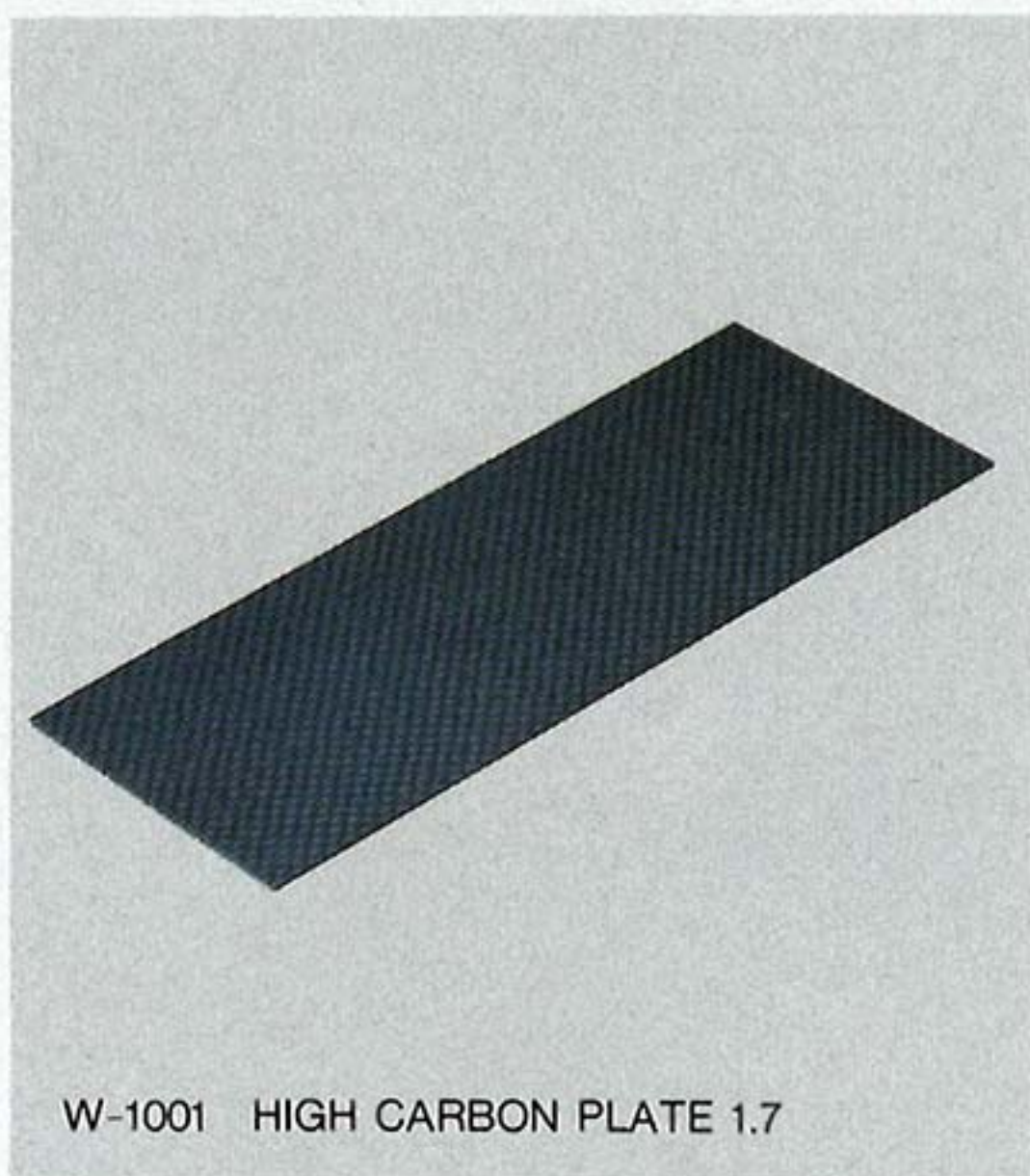
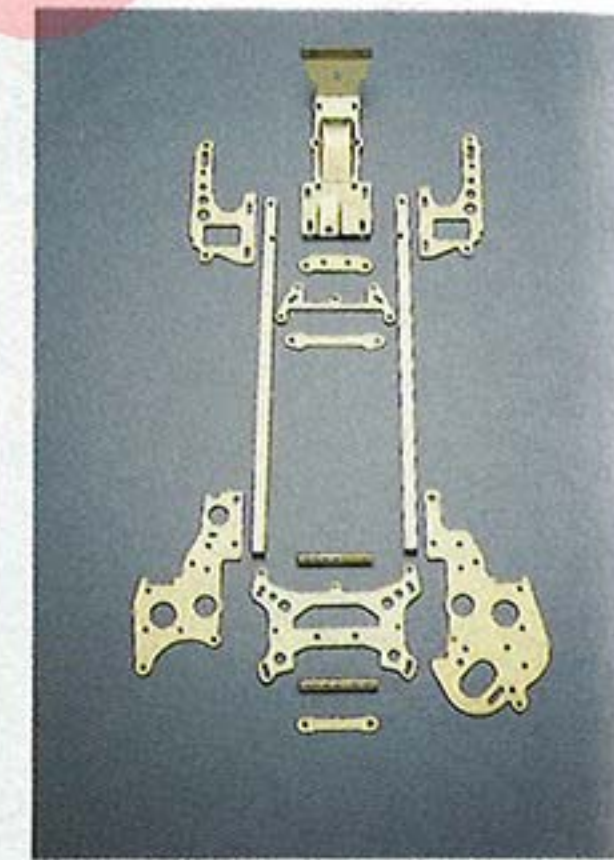

W-1001 HIGH CARBON PLATE 1.7



W-5001(S)/W-5002(L)  
PRESSURE SHOCK  
(PAIR)



W-5009(9T)  
W-5010(10T)  
W-5011(11T) HARD PINION GEAR

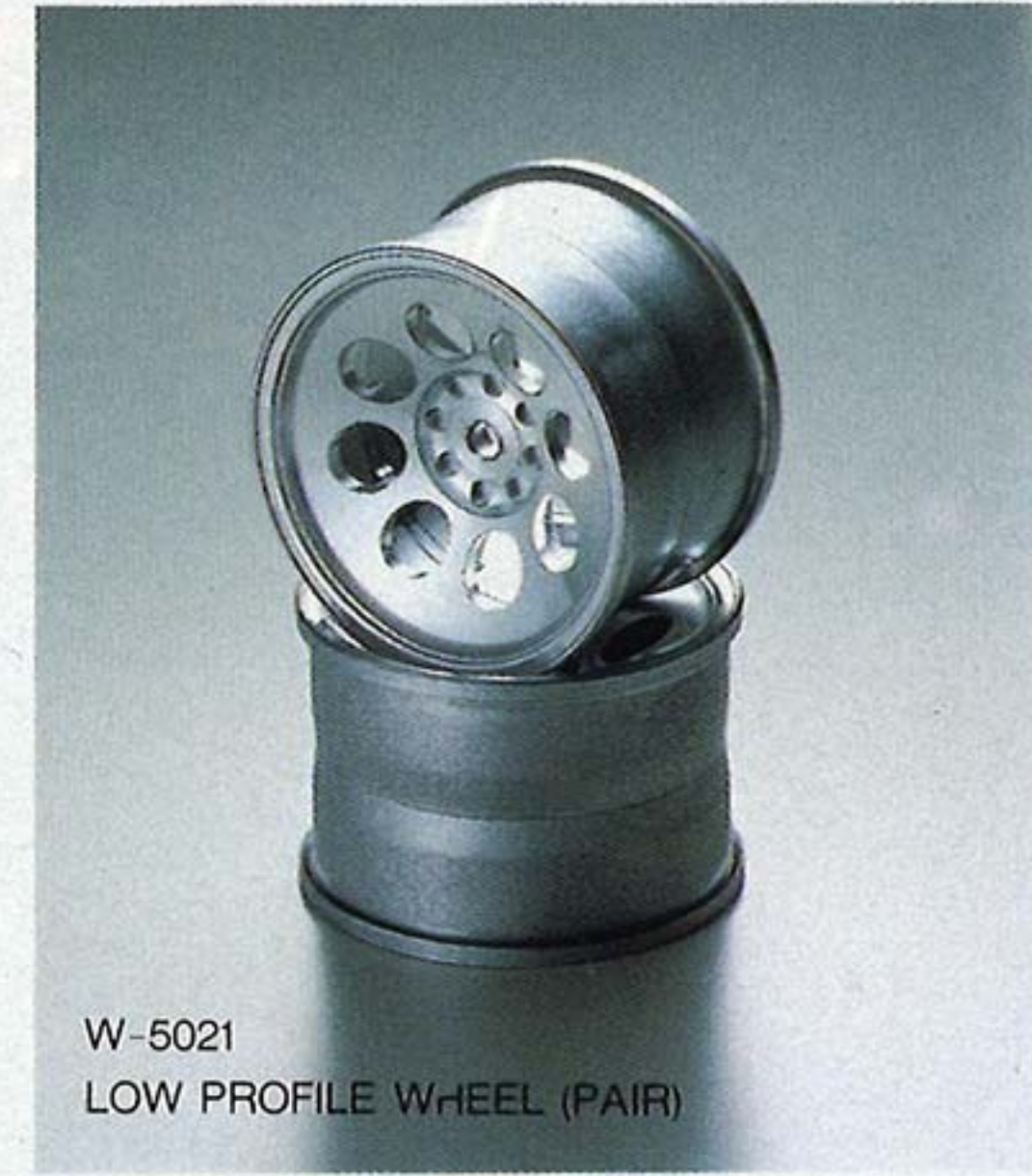

W-5021  
LOW PROFILE WHEEL (PAIR)



W-5031  
LOW PROFILE TIRE, ALLROUND TYPE  
(PAIR, WHEEL IS NOT INCLUDED.)

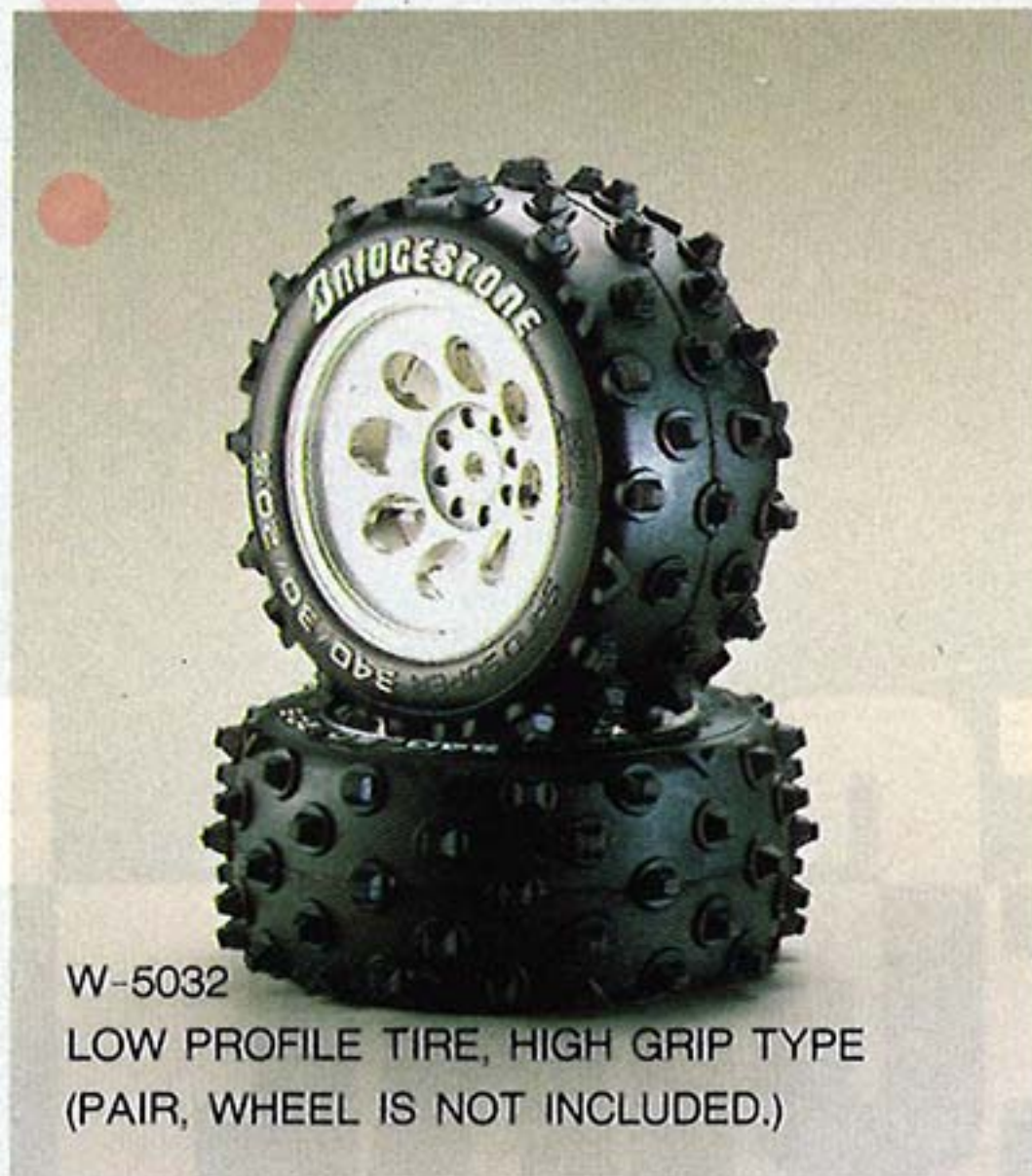

W-5032  
LOW PROFILE TIRE, HIGH GRIP TYPE  
(PAIR, WHEEL IS NOT INCLUDED.)



W-5044(14T)  
W-5046(16T)  
W-5048(18T) RACING CLUTCH



W-5040(10T)  
W-5042(12T) RACING CLUTCH





W-5061(FOR OPTIMA SERIES)  
W-5062(FOR ROCKY)  
UNIVERSAL SWING SHAFT

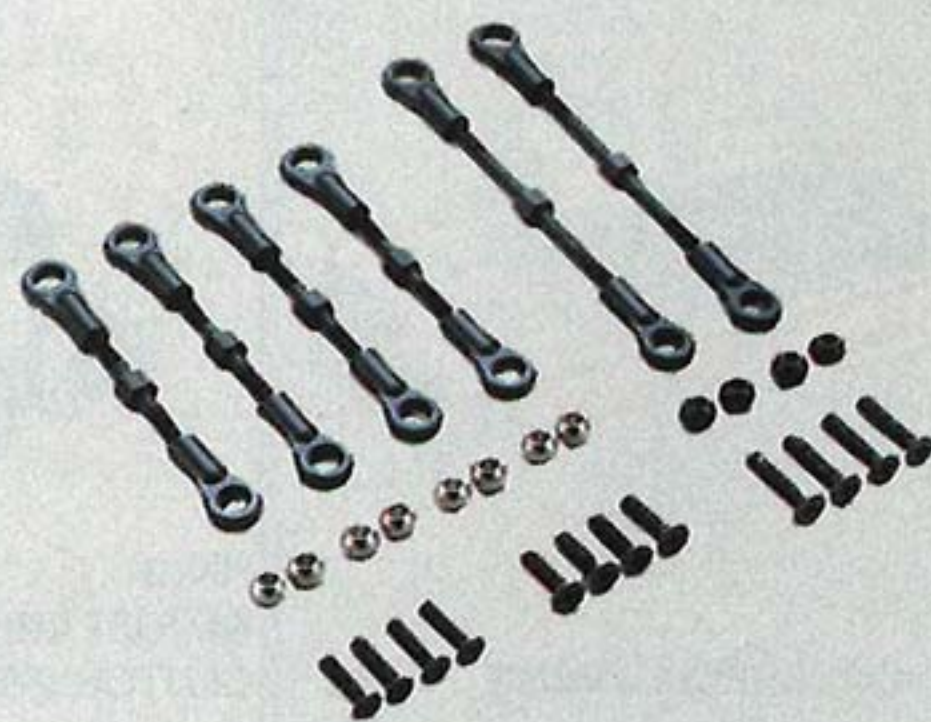

W-5005 SPECIAL ROD SET



W-0104 SPECIAL MAIN CHASSIS



W-5003(S)/W-5004(L)  
PLATINUM OIL SHOCKS

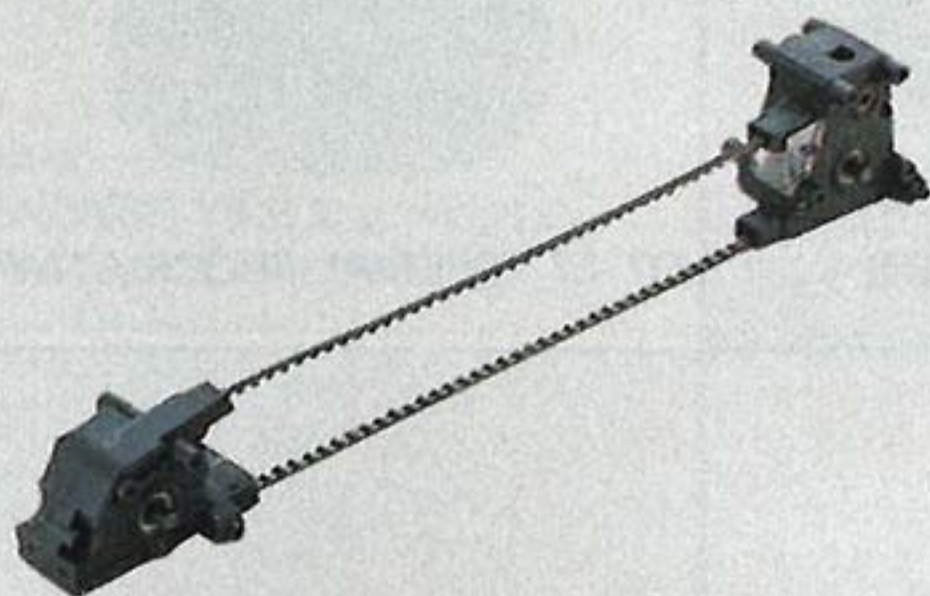

W-0105  
BELT DRIVE UNIT  
(FOR OPTIMA SERIES)



W-0106  
ADJUSTABLE ONE-WAY CLUTCH  
(FOR OPTIMA SERIES)

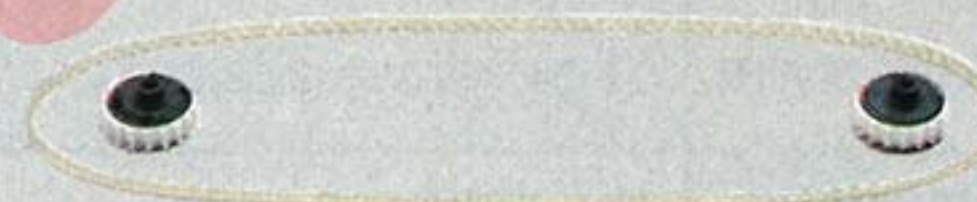

W-5051  
BELT DRIVE UNIT  
(FOR STINGER SERIES)

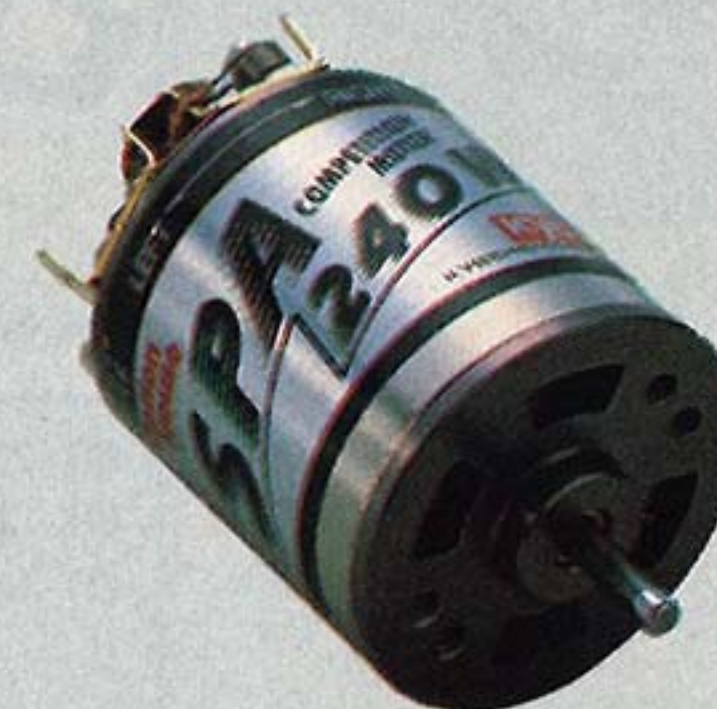

W-1011  
COMPETITION MOTOR  
SPA-240WS



W-1012  
COMPETITION MOTOR  
SPA-480WT

- |             |             |
|-------------|-------------|
| W-5085(15T) | W-5091(21T) |
| W-5086(16T) | W-5092(22T) |
| W-5087(17T) | W-5093(23T) |
| W-5088(18T) | W-5094(24T) |
| W-5089(19T) | W-5095(25T) |
| W-5090(20T) |             |



HARD PINION GEAR



# SPECIAL PARTS LIST

## ELECTRIC POWERED RACING BUGGY

 <p>EF-103 RACING WIRE</p>	 <p>OT-56 LIGHT WEIGHT ALUMINUM SELF TAPPING SCREW SET</p>	 <p>LM-15 MOTOR COOLING PLATE</p>	 <p>OT-64 SPECIAL WING</p>	 <p>RK-31 ADJUSTABLE ONE-WAY CLUTCH (FOR ROCKY/TURBO ROCKY)</p>	 <p>UM-28 MOTOR GUARD</p>
 <p>UM-27 SPECIAL CHASSIS</p>	 <p>UM-30 SPECIAL RADIO PLATE</p>	 <p>OT-54 STABILIZER SET</p>	 <p>UM-29 STABILIZER SET</p>	 <p>RK-30 STABILIZER SET</p>	 <p>OT-57 SPECIAL SHOCK STAY</p>
 <p>UM-26 SPECIAL SHOCK STAY</p>	<p>OT-23(12T)    OT-24(15T) OT-50(13T)    OT-52(16T) OT-51(14T)    OT-53(17T)</p>  <p>PINION GEAR</p>	<p>UM-23(18T) UM-24(19T) UM-25(20T)</p>  <p>PINION GEAR</p>	 <p>OT-76 HARD FINAL PINION GEAR</p>	 <p>MS-26 BALL BEARING 6φ×10φ, W/FLANGE</p>	 <p>P 1-15 BALL BEARING 8φ×12φ</p>
 <p>1901 BALL BEARING 5φ×10φ</p>	 <p>1903 BALL BEARING 4φ×8φ</p>	 <p>1911 BALL BEARING 8φ×14φ</p>	 <p>1971 BALL BEARING SET (FOR OPTIMA)</p>	 <p>1972 BALL BEARING SET (FOR ROCKY 4WD)</p>	 <p>1974 BALL BEARING SET (FOR ULTIMA)</p>





 <p>OT-67 WHEEL (FOR LOW PROFILE TIRE) (PAIR)</p>	 <p>UM-17 WHEEL SET (FRONT, REAR×2PCS.)</p>	 <p>RK-2 WHEEL SET(PAIR)</p>	 <p>OT-66 LOW PROFILE TIRE (PIN TYPE)  (PAIR, WHEEL IS NOT INCLUDED.)</p>	 <p>RK-15 LOW PROFILE TIRE (SQUARE BLOCK)  (PAIR, WHEEL IS NOT INCLUDED.)</p>	 <p>1871 SPONGE TIRE A (PAIR, WHEEL IS NOT INCLUDED.)</p>
 <p>1872 SPONGE TIRE B LOW PRO. (PAIR, WHEEL IS NOT INCLUDED.)</p>	 <p>1873 RUBBER TIRE A (PAIR, WHEEL IS NOT INCLUDED.)</p>	 <p>1874 RUBBER TIRE B (PAIR, WHEEL IS NOT INCLUDED.)</p>	 <p>OT-65 WING STAY SET</p>	 <p>OT-38 SILICON GREASE (2PCS.)</p>	 <p>1883 TEFLON HOBBY OIL, FRONTIER (30cc)</p>
 <p>1951 SHOCK OIL SET (S.M.H.)</p>	 <p>1952 DIFFERENTIAL OIL</p>	 <p>1990 REGULATOR (8.4V)</p>	 <p>1863 SPONSOR STICKER</p>	 <p>NO.1953(S) NO.1954(M) NO.1955(H)  SILICON OIL</p>	 <p>OTW-1 STABILIZER SET (FOR OPTIMA MID)</p>
 <p>OTW-2 SPECIAL SHOCK STAY (FOR OPTIMA MID)</p>	 <p>OTW-3 SPECIAL CHASSIS (FOR OPTIMA MID)</p>	 <p>NO.1875 FRONT TIRE(A) (PAIR,WHEEL IS NOT INCLUDED)</p>	 <p>OT-90 WHEEL</p>		



# OPTION HOUSE

## FOR ELECTRIC POWERED RACING BUGGY



Parts No.	Parts Name	Available Model													
		ICARUS	COSMO	RAIDER 2WD	ULTIMA	GALLOP MK II	ROCKY 4WD	SHADOW 4WD	JAVELIN	OPTIMA PRO	OPTIMA MID	TURBO OPTIMA MID	TURBO ROCKY	TURBO OPTIMA	BIG BRUTE
		PEGASUS							OPTIMA					SALUTE	
W-0101	MOTOR GUARD								●	●				●	
W-0102	SIDE GUARD								●	●				●	
W-0103	GOLD PLATE SET								●	●				●	
W-1001	HIGH CARBON PLATE1.7				▲	▲	▲		▲	▲	▲	▲	▲	▲	
W-5001	PRESSURE SHOCK(S) (PAIR)			●	UM-26				●	●	○	○	●	○	
W-5002	PRESSURE SHOCK(L) (PAIR)			●	UM-26		●		●	●	○	○	●	○	●
W-5009	HARD PINION GEAR 9T								●	●				○	
W-5010	HARD PINION GEAR 10T								●	●				●	
W-5011	HARD PINION GEAR 11T								●	●				●	
W-5005	SPECIAL ROD SET				●		●		●	●	●	○	●	●	
W-5061	UNIVERSAL SWING SHAFT				●				●	●	●	○		●	
W-5062	UNIVERSAL SWING SHAFT			●			●						●		
W-5040	RACING CLUTCH 10T								●	●				●	
W-5042	RACING CLUTCH 12T				●		●		●	●			●	●	
W-5044	RACING CLUTCH 14T				●		●		●	●			●	●	
W-5046	RACING CLUTCH 16T				●		●		●	●			●	●	
W-5048	RACING CLUTCH 18T	●	○		●										
W-5021	LOW PROFILE WHEEL(PAIR)	▽	●		●		●	●	●	●	●	●	●	●	
W-5031	LOW PROPILE TIRE, ALLROUND TYPE(PAIR,WHEEL IS NOT INCLUDED)	■	●	■	●		●	●	●	●	●	●	●	●	
W-5032	LOW PROPILE TIRE, HIGH GRIP TYPE(PAIR,WHEEL IS NOT INCLUDED)	■	●	■	●		●	●	●	●	●	●	●	●	
W-0104	SPECIAL MAIN CHASSIS								●	●				●	
W-5003	PLATINUM OIL SHOCKS(S)			●	UM-26			●	●	●	●	●	○	●	
W-5004	PLATINUM OIL SHOCKS(L)			●	UM-26		●	●	●	●	●	●	○	●	●
W-0105	BELT DRIVE UNIT (FOR OPTIMA SERIES)								●	●				●	
W-0106	ADJUSTABLE ONE-WAY CLUTCH (FOR OPTIMA SERIES)								●	●				●	
W-5085	HARD PINION GEAR (15T)										●	●			
W-5086	" (16T)										●	●			
W-5087	" (17T)										●	●			
W-5088	" (18T)										●	●			
W-5089	" (19T)										●	●			
W-5090	" (20T)										○	○			
W-5091	" (21T)										●	●			
W-5092	" (22T)										●	●			
W-5093	" (23T)										●	●			
W-5094	" (24T)										●	●			
W-5095	" (25T)										●	●			

● = Available (Not included). ○ = Included in Kit. ▲ = Available under necessary processing. ■ = Use them with Wheel of Low Profile Tire (OT-67, UM-17, RK-2 & W5021). □ = Use them with Wheel set (OT-3 & OT-62).  
 ▽ = Use them with Front Wheel (PI-21). UM-26 = Use recommended part with the No. indicated.

Note: Please check the part No., part name and contents of each part and then specify them when you buy your required part at model shop.



# SPECIAL PARTS

## FOR ELECTRIC POWERED RACING BUGGY

# SPECIAL PARTS

Parts No.	Parts Name	Available Model												
		ICARUS PEGASUS	COSMO	RAIDER 2WD	ULTIMA	GALLOP MK II	ROCKY 4WD	SHADOW 4WD	JAVELIN OPTIMA	OPTIMA PRO	OPTIMA MID	TURBO OPTIMA MID	TURBO ROCKY	TURBO OPTIMA SALUTE
OT-23	PINION GEAR 12T					●	●		○	○		●	●	●
OT-50	PINION GEAR 13T					●	●		●	●		●	●	○
OT-51	PINION GEAR 14T				●	○	○		●	●		○	●	●
OT-24	PINION GEAR 15T				○	○	●		○	○		●	●	●
OT-52	PINION GEAR 16T				●	●	●		●	●		●	●	●
OT-53	PINION GEAR 17T				●	●	●		●	●		●	●	●
UM-23	PINION GEAR 18T	○	●		●									
UM-24	PINION GEAR 19T	●	●		●									
UM-25	PINION GEAR 20T				●									
OT-76	HARD FINAL PINION GEAR				▲				●	●			●	
MS-26	BALL BEARING 6φ×10φ, w/FLANGE	●	●			●								
PI-15	BALL BEARING 8φ×12φ	●	●											●
OT-67	WHEEL (FOR LOW PROFILE TIRE) (PAIR)	▽	●	●	●		●	●	●	○	●	●	●	○
UM-17	WHEEL SET (FRONT, REAR×2PCS.)	▽	●	●	○		●	●	●	●	●	●	●	●
RK-2	WHEEL SET (PAIR)	▽	○	●	●		○	●	●	●	●	○	●	
OT-66	LOWPROFILE TIRE (PIN TYPE) (PAIR,WHEEL IS NOT INCLUDED.)	■	●	■	○		●	●	■	○	○	○	●	○
RK-15	LOWPROFILE TIRE (SQUARE BLOCK) (PAIR,WHEEL IS NOT INCLUDED.)	■	○	■	●		○	●	■	●	●	○	●	
OT-64	SPECIAL WING	●		●	●	●	●		●	●	●	●	●	●
OT-65	WING STAY SET								●	●			●	
OT-38	SILICON GREASE (2PCS.)	●	●	●	●	●	●		○	○	○	○	●	○
LM-15	MOTOR COOLING PLATE	●	●	●	●	●	●		●	●	●	○	●	●
OT-56	LIGHTWEIGHT ALUMINUMSELF TAPPING SCREWSET								●	●			●	
1901	BALL BEARING5φ×10φ			●	●		○	●	●	○	○	○	●	●
1903	BALL BEARING4φ×8φ	●	●	●	●	●	●	●	●	○	○	○	●	●
1911	BALL BEARING8φ×14φ			●	●		●	○	○	○	○	○	○	○
1872	SPONGE TIRE B (PAIR,WHEEL IS NOT INCLUDED.)	●	●	■	●		●	■	■	●	■	■	●	●
1871	SPONGE TIRE A (PAIR,WHEEL IS NOT INCLUDED.)	●	□	●	□	●	□	□	●	□	□	□	□	□
1873	RUBBER TIRE A( PAIR,WHEEL IS NOT INCLUDED.)	●	□	●	□	●	□	□	●	□	□	□	□	□
1874	RUBBER TIRE B( PAIR,WHEEL IS NOT INCLUDED.)	●	□	●	□	●	□	□	●	□	□	□	□	□
1952	DIFFERENTIAL OIL				●	●	●		●	●	●	●	●	●
1990	REGULATOR (8.4V)	▲	▲		●	●	●	●	●	●	●	●	●	○
1875	FRONT TIRE (A)		●	○	●									●
OT-90	WHEEL				●	●	●		●	○	○	●	●	
OTW-1	STABILIZER SET (FOR OPTIMA MID)									●	○			
OTW-2	SPECIAL SHOCK STAY (FOR OPTIMA MID)									●	○			
OTW-3	SPECIAL CHASSIS (FOR OPTIMA MID)									●	○			

●=Available(Not included). ○=Included in Kit. ▲=Available under necessary processing. ■=Use them with Wheel of Low Profile Tire (OT-67, UM-17, RK-2 & W5021). □=Use them with Wheel set (OT-3 & OT-62).  
▽=Use them with Front Wheel (PI-21). UM-26=Use recommended part with the No. indicated.

Note: Please check the part No., part name and contents of each part and then specify them when you buy your required part at model shop.



**LOW-VOLTAGE SOLDERING IRON** NO.1825 • 2800

**HANDY IRON** NO.1826 • 2800

**HOT KNIFE SOLDERING IRON** NO.378 • 1800



■ **HANDY IRON** NO.1826

THIS SUBMINIATURE, LIGHT-WEIGHT IRON WITH FLAT AND ROUND TIPS INCLUDED WORKS WELL NOT ONLY FOR DELICATE JOBS SUCH AS AROUND AILERONS AND DEPRESSED PORTIONS, BUT ALSO FOR COVERING VARIOUS SORTS OF FILMS ON FUSELAGES AND WINGS. IT IS PROVIDED WITH TWO SWITCHES; FOR HIGH AND LOW TEMPERATURE. 100V/20W, FLUORINE TREATED (SAME AS TEFLON TREATED).

FER À ENTOILER MINIATURE TRÈS LÉGER FOURNI AVEC PANNES PLATE ET ARRONDIE, PERMETTANT DE TRAVAILLER AUX ENDOITS LES MOINS ACCESSIBLES ET LES PLUS DÉLICATS. L'APPAREIL EST À DEUX POSITIONS DE TEMPÉRATURE. PUISSANCE 100V/20W. SEMELLE EN FLUORINE (SIMILAIRE AU TEFLON).

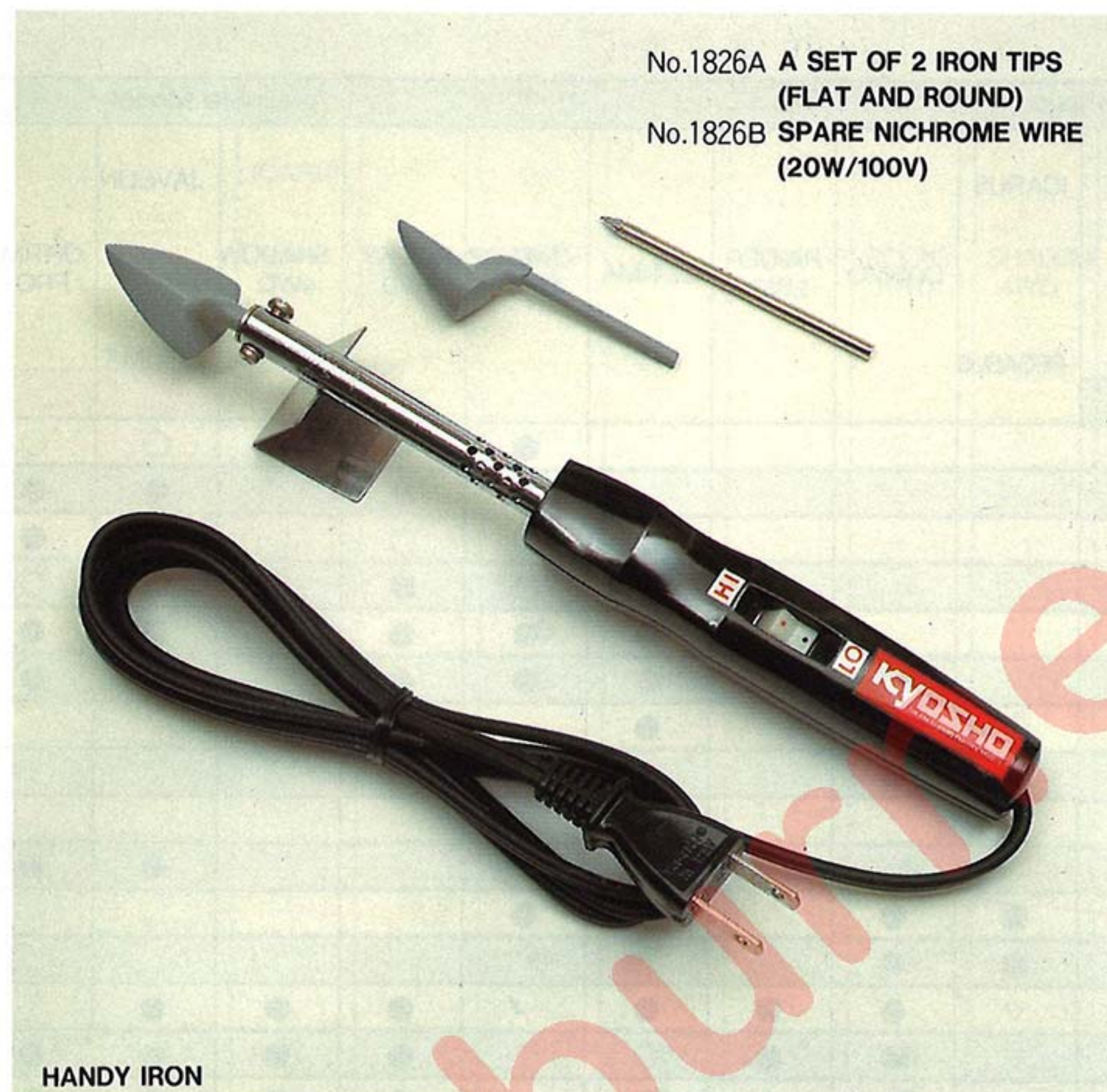

HANDY IRON

No.1826A A SET OF 2 IRON TIPS (FLAT AND ROUND)

No.1826B SPARE NICHROME WIRE (20W/100V)

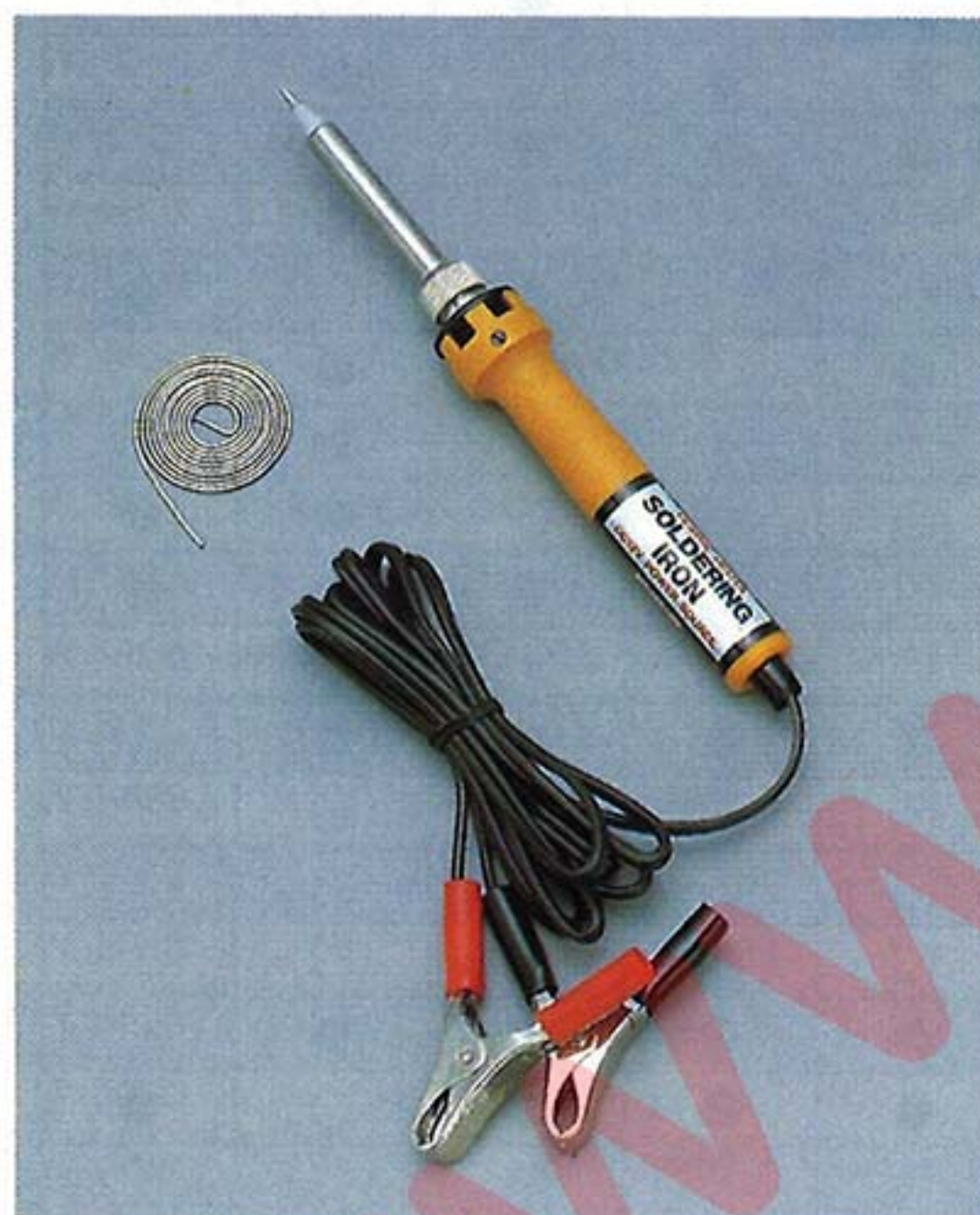

■ **LOW-VOLTAGE SOLDERING IRON** NO.1825 OPERATES FROM 12V CAR BATTERY. CARRY TO FIELD IN TOOL KIT. FAST ONE-MINUTE WARM-UP DUE TO CERAMIC ELEMENT. 18W.

ALIMENTATION SUR BATTERIE D'AUTOMOBILE 12V. OUTIL DESTINÉ AUX TRAVAUX SUR LE TERRAIN, ET QUI CHAUFFE EN MOINS D'UNE MINUTE. ÉLÉMENT CÉRAMIQUE 18W.



HOT KNIFE SOLDERING IRON

No.378B SPARE BLADE, 12 EACH  
No.378D SPARE CHUCK

■ **HOT KNIFE SOLDERING IRON** NO.378

THIS IS A COMBINATION OF A KNIFE AND A SOLDERING IRON 30W/100V. IT CUTS EVEN THICK PLASTIC SHEET VERY EASILY SINCE IT CUTS WHILE SOFTENING THE OBJECTS BY HEAT.

COMBINAISON DE COUTEAU THERMIQUE ET DE FER À SOUDER 30W/100V. PERMET DE DÉCOUPER MÊME LES MATIÈRES PLASTIQUES DE FORTE ÉPAISSEUR PAR EFFET THERMIQUE.





## POLYCA COLOR

NO.2230 ● 300

### ■ POLYCA COLOR NO.2230

POLYCA ACRYLIC PAINT IS SPECIALLY FORMULATED FOR USE ON NEARLY ALL PLASTIC MATERIALS USED IN MODELS, SUCH AS POLYSTYRENE, POLYCARBONATE, ABS, BUTYRATE, ETC.

LA PEINTURE ACRYLIQUE POLYCA EST CONÇUE POUR L'APPLICATION SUR TOUTES LES MATIÈRES PLASTIQUES UTILISÉES EN MODÉLISME, TELLES QUE LE POLYSTYRÈNE, LE POLYCARBONATE, L'ABS, LE BUTYRATE, ETC.



## HOBBY SHEARS & SANDER

NO.1829 ● 1000

## MICRON LINE TAPE

NO.1841 NO.1842 NO.1843 ● 300



POLYCA COLOR

### ■ MICRON LINE TYPE

MICRON LINE TAPE GIVES THE LOOK THAT MARKS THE WORK OF A CRAFTSMAN, NEAT STRIPES OF EVEN WIDTH FROM ONE END TO THE OTHER. MICRON LINE CAN FOLLOW ALMOST ANY CURVE AND IS SELF-ADHESIVE, STICKING WITH JUST A TOUCH TO ANY SMOOTH SURFACE, SUCH AS PLASTIC CAR BODIES, SILKYCOTE, EXCELCOTE AND OTHER FINISHING MATERIALS, DOPED SURFACES, ETC. MICRON LINE TAPE COMES IN 6 COLORS AND 1, 1.5 AND 2.5mm WIDTHS (5m LENGTH).

MICRONLINE EST UNE GAMME DE FILETS DE DÉCORATION QUI DONNENT AUX MODÈLES RÉDUITS UN CACHET PROFESSIONNEL. LE MICRONLINE PERMET DE RÉALISER DES FILETS DE LARGEUR CONSTANTE, IL EST ADHÉSIF ET S'ADAPTE À TOUTES LES COURBES DU MODÈLE. IL ADHÈRE MOYENNANT UNE SIMPLE PRESSION ET POUR TOUTES LES FORMES DE FINITION. LE MICRONLINE EXISTE EN 6 COULEURS ET EN LARGEURS DE 1-1,5 ET 2,5mm (EN ROULEAUX DE 5M.).

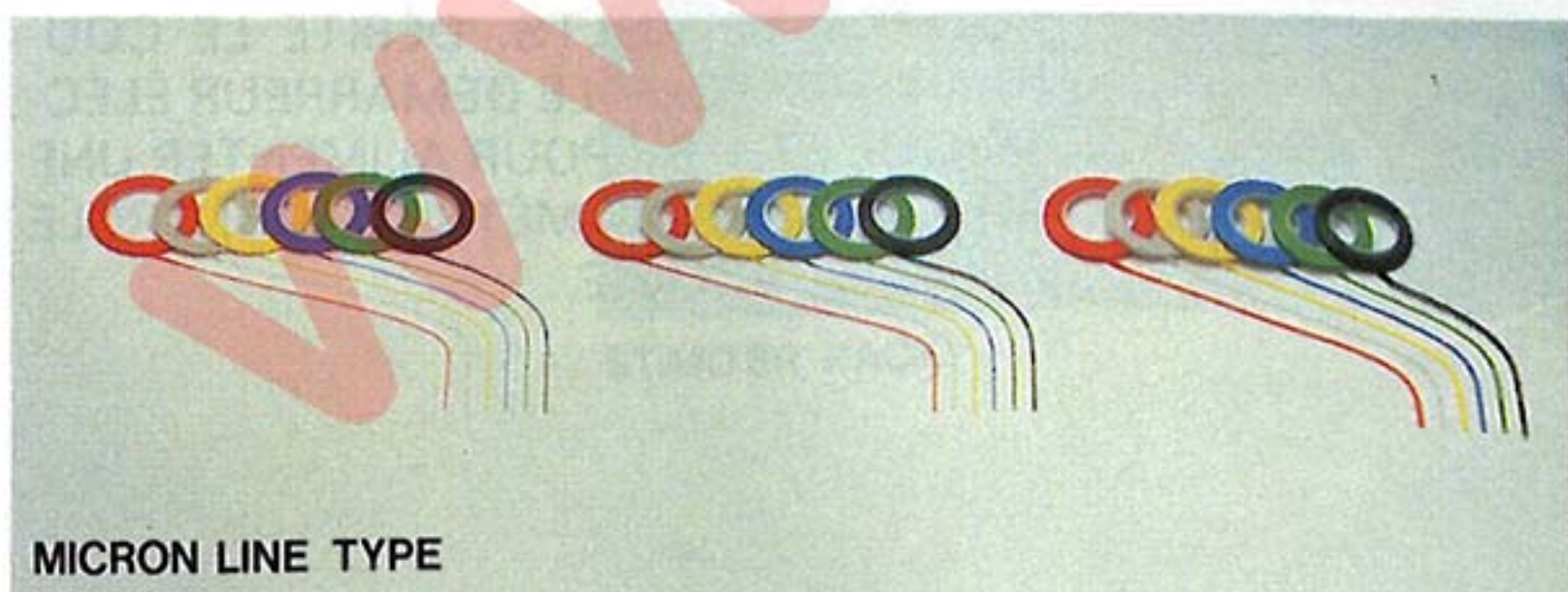
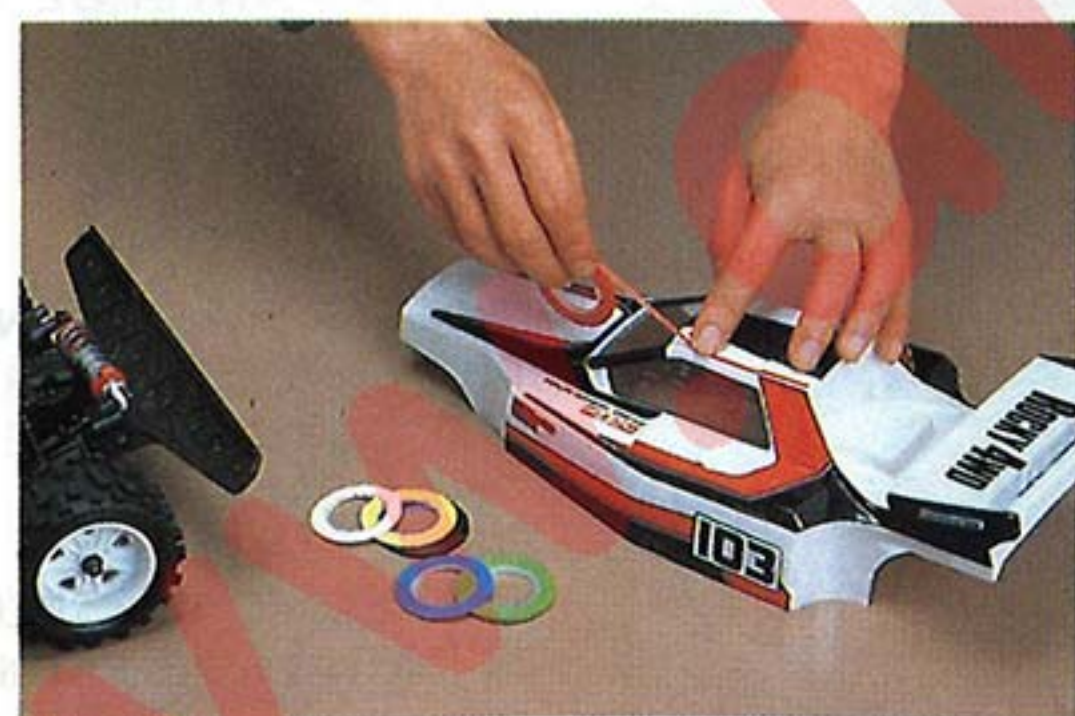

MICRON LINE TYPE



HOBBY SHEARS AND SANDER

### ■ HOBBY SHEARS AND SANDER NO.1829

FOR CUTTING AND TRIMMING PLASTIC CAR BODIES, AND FOR USE AS UTILITY SHEARS FOR CUTTING THIN ALUMINUM AND OTHER SOFT METALS, PLASTIC SHEET, FIBERGLASS CLOTH, ETC. FLAT INNER SECTION OF BLADES MAKES STRAIGHT CUTS, WHILE CURVED TIPS MAKE TIGHT INSIDE CUTS FOR WHEEL-HELLS, ETC.

### CISEAUX DE MODÉLISME

CES CISEAUX SONT DESTINÉS À DÉCOUPER LES CARROSSERIES DE VOITURES, ET AU DÉCOUPAGE DE FINE TÔLE D'ALUMINIUM ET AUTRES MÉTAUX DOUX, DES PLAQUES DE PLASTIQUE, DU TISSU DE VERRE, ETC. LA PARTIE PLATE DES CISEAUX PERMET DE COUPER EN LIGNE DROITE, ALORS QUE LES POINTES COURBÉES SONT DESTINÉES AUX ARRONDIS.



## BLITZ STARTER

NO.1791 • 6800

## POWER DIVIDER

12 VOLT D.C. DIVIDER TO 1.5 VOLT AND 12 VOLT. NO.1835 • 4800

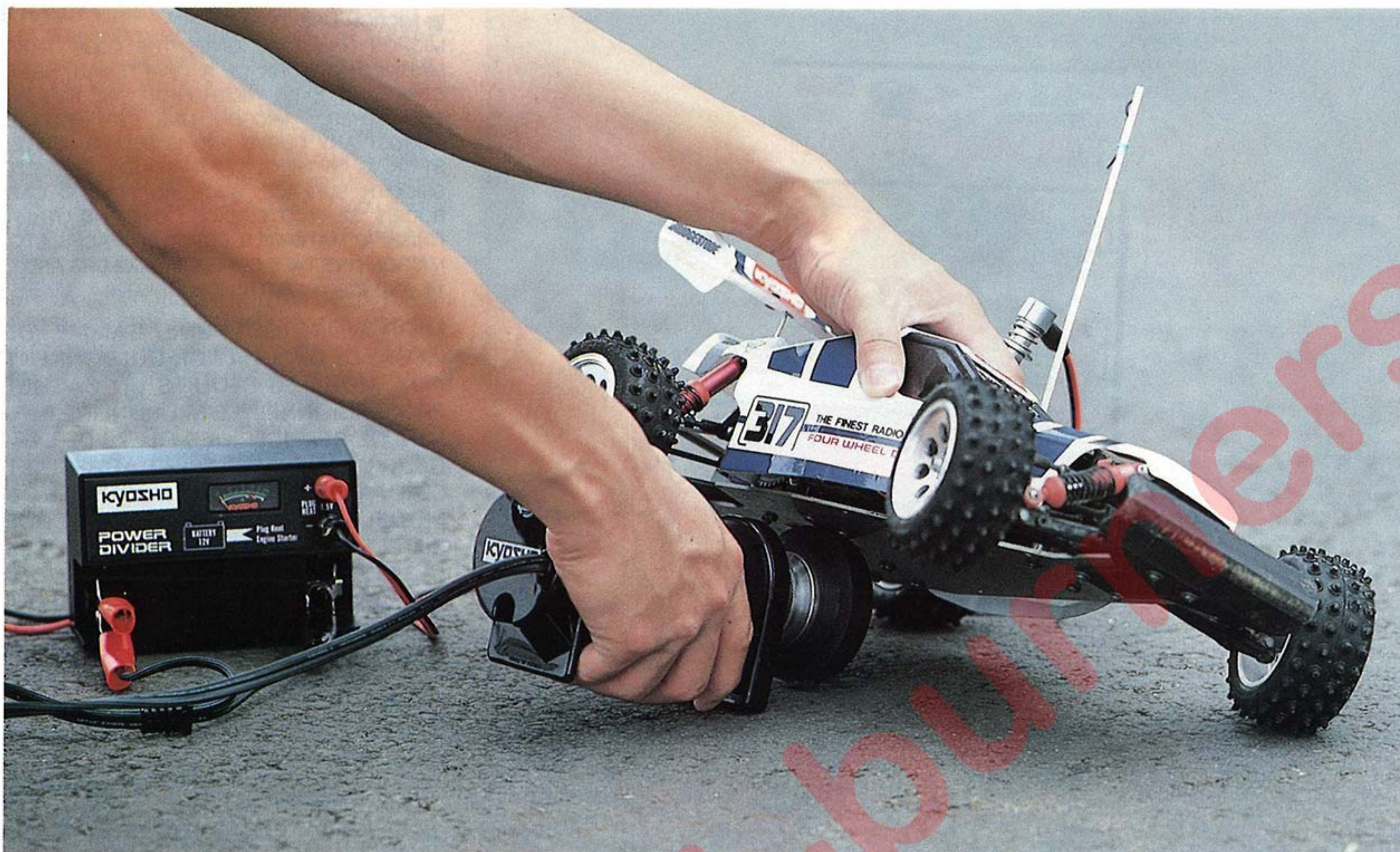

BLITZ STARTER

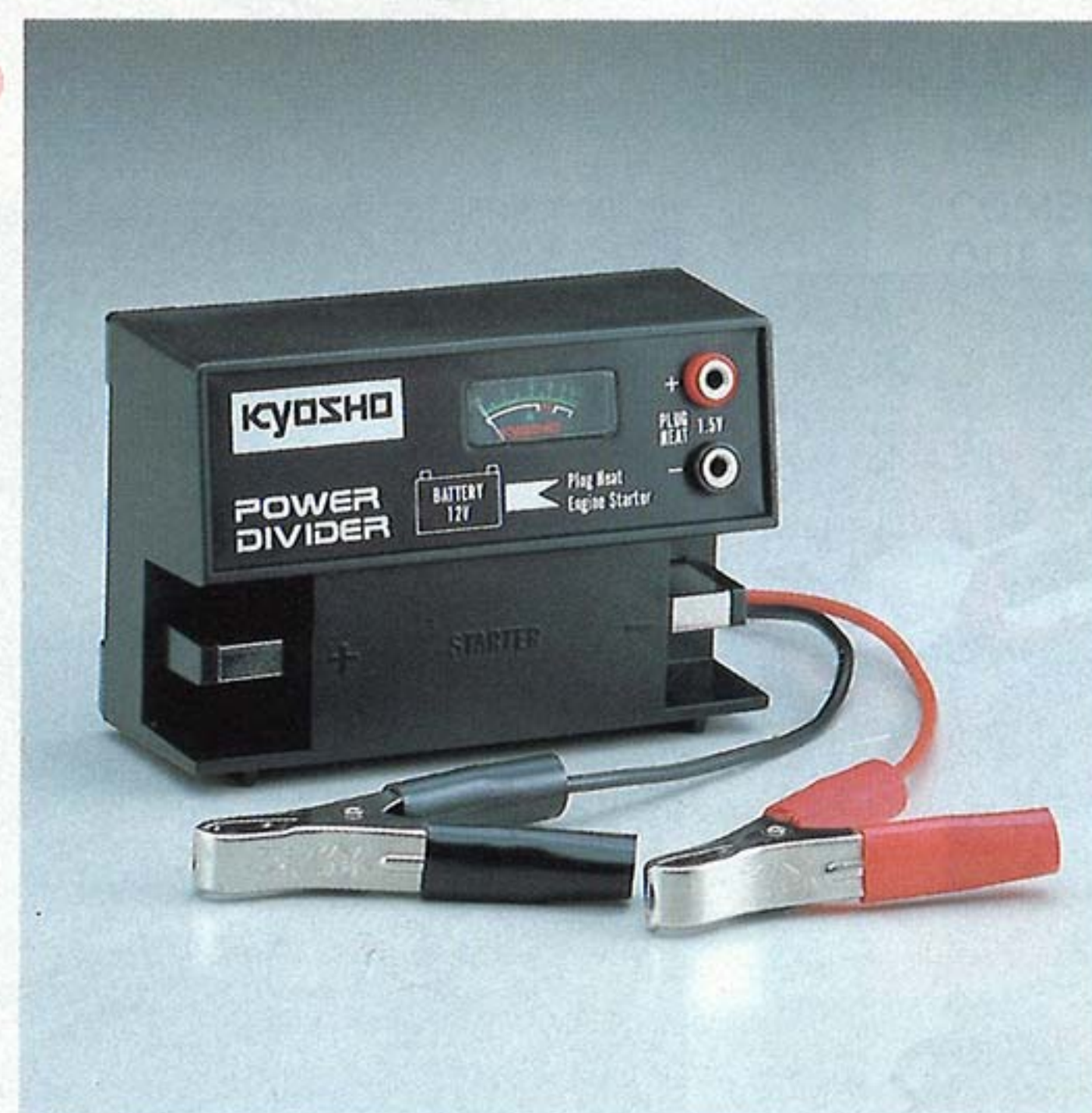

POWER DIVIDER

### ■ BLITZ STARTER NO.1791

- DIRECT-DRIVE, HIGH-SPEED, HIGH-TORQUE TYPE.
- STARTS 2-STROKE ENGINES UP TO. 61, 4-STROKE UP TO. 91 SIZE.
- STARTS SMALL 2-STROKE ENGINES THAT REQUIRE HIGH CRANKING SPEED.
- STARTS AIRCRAFT ENGINES WITH OR WITHOUT SPINNER.
- STARTS CAR ENGINES BY RUBBER DRIVE WHEEL (OPTION #BZ-1).
- STARTS HELICOPTERS/BOATS USING BELT BY GROOVED PULLEY (BELT NOT INCLUDED).
- SQUEEZE-TYPE SWITCH FOR CONVENIENT ONE-HAND OPERATION.
- COLOR-CODED BATTERY CLIPS FITTED.
- OPERATES FROM 12V BATTERY (5Ah OR HIGHER).

- TYPE À ENTRAÎNEMENT DIRECT, GRANDE VITESSE ET PUISSANT.
- PEUT LANCER DES MOTEURS 2T JUSQUE 10cm<sup>3</sup> ET 4T JUSQUE 15cm<sup>3</sup>.
- LANCE FACILEMENT LES MOTEURS 2T DE FAIBLE CYLINDRÉE, QUI NÉCESSITENT UNE GRANDE VITESSE.
- APPLICABLE EN AVION, AVEC OU SANS CÔNE D'HÉLICE.
- DÉMARRE LES VOITURES RC PAR L'INTERMÉDIAIRE D'UNE ROULETTE EN CAOUTCHOUC (OPTION BZ-1).
- DÉMARRE LES MOTEURS DE BATEAUX ET D'HÉLICOPTÈRES PAR L'INTERMÉDIAIRE D'UNE COURROIE (NON COMPRIS).
- INTERRUPTEUR À PRESSION.
- PINCES DE RACCORDEMENT COLORÉES COMPRIS.
- FONCTIONNE SUR LES BATTERIES DE 12V À PARTIR DE 5Ah.

### ■ POWER DIVIDER NO.1835

TWO SETS OF POWER SUPPLIES AVAILABLE JUST CONNECTING THE "POWER DIVIDER" TO 12VOLT BATTERY, 1.5V GLOW PLUG AND 12V ENGINE STARTER.

ALSO, EASY TO FIND DEFECTIVE OF PLUG WITH INDICATION AN ELECTRIC CURRENT METER.

TABLEAU D'ALIMENTATION POUR SOURCE 12 VOLTS. DÉBITE LE COURANT 12V POUR LE DÉMARREUR ÉLECTRIQUE ET 1,5V POUR ALIMENTER UNE BOUGIE. AMPÈRE-MÈTRE DE CONTRÔLE POUR LA BOUGIE.



## STARTER PACK

STARTING SET FOR MODEL GLOW-PLUG ENGINES  
NO.1798 ● 2800

## HYPER 500

FUEL FOR MODEL GLOW-PLUG ENGINES  
NO.1795 ● 800



### STARTER PACK NO.1798

ALL IN ONE PACK ARE THE MATERIALS NEEDED FOR STARTING AND RUNNING A MODEL GLOW ENGINE. INCLUDED ARE A 500mL CONTAINER (REUSABLE AS A PRIMING BOTTLE), FILLER NOZZLE, PLUG-HEATER BATTERY BOX (USES ECONOMICAL D-SIZE ALKALINE DRY CELLS), PLUG WRENCH AND CONNECTOR CABLES. HYPER 500 FUEL IS BLENDED OF HIGH QUALITY INGREDIENTS AND CONTAINS 10% NITROMETHANE FOR SMOOTH RUNNING, HIGH POWER AND RELIABLE IDLING IN CARBURETOR-EQUIPPED ENGINES.

CAISSE DE SERVICE POUR TOUS LES MOTEURS THERMIQUES. ELLE COMPREND 500ml DE CARBURANT, LE TUBE DE REMPLISSAGE, LE BOÎTIER À PILES POUR LA BOUGIE (ALKALINE D SÈCHES). LA CLÉ À BOUGIE, LA PINCE DE RACCORDEMENT. LE CARBURANT HYPER 500 COMPREND DES COMPOSANTS DE QUALITÉ ET NOTAMMENT 10% DE NITROMÉTHANE EN VUE D'AMÉLIORER LE FONCTIONNEMENT DU MOTEUR, LA PUISSANCE, LE RALENTI ET LA MISE EN MARCHÉ.



STARTER PACK

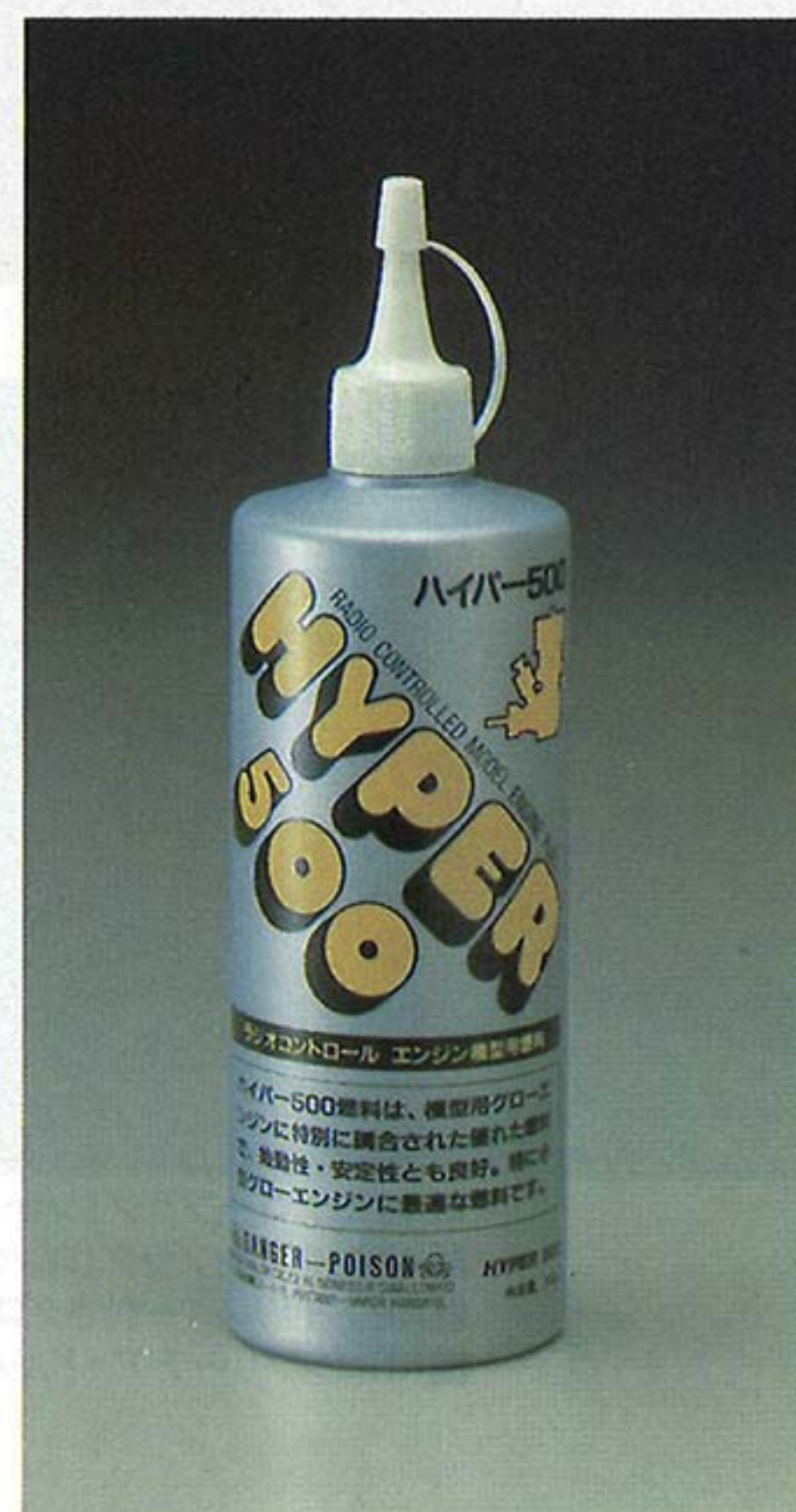

HYPER 500 NO.1795



# K&B FUELS & GLOW PLUGS

MADE IN USA



- K&B500Hカラード 3.8ℓ No.6509 ● 4800
- K&B125 4cycle 3.8ℓ No.6058 ● 4800
- K&B100 3.8ℓ No.6051 ● 3800
- K&B100+ 3.8ℓ No.6053 ● 3800
- K&BF.A.180-20 3.8ℓ No.6056 ● 3000
- K&B500 3.8ℓ No.6054 ● 4800
- K&Bスーパースピード 3.8ℓ No.6052 ● 11000
- K&B1000 1ℓ No.6121 ● 1900
- K&B1000+ 1ℓ No.6122 ● 1900



● JAPANESE MARKET ONLY.



- KBISグロープラグ(ショート) No.7321
- KBILグロープラグ(ロング) No.7311
- KBアイドルバー付きグロープラグ No.4530
- KBロングリーチアイドルバー付きグロープラグ No.4520



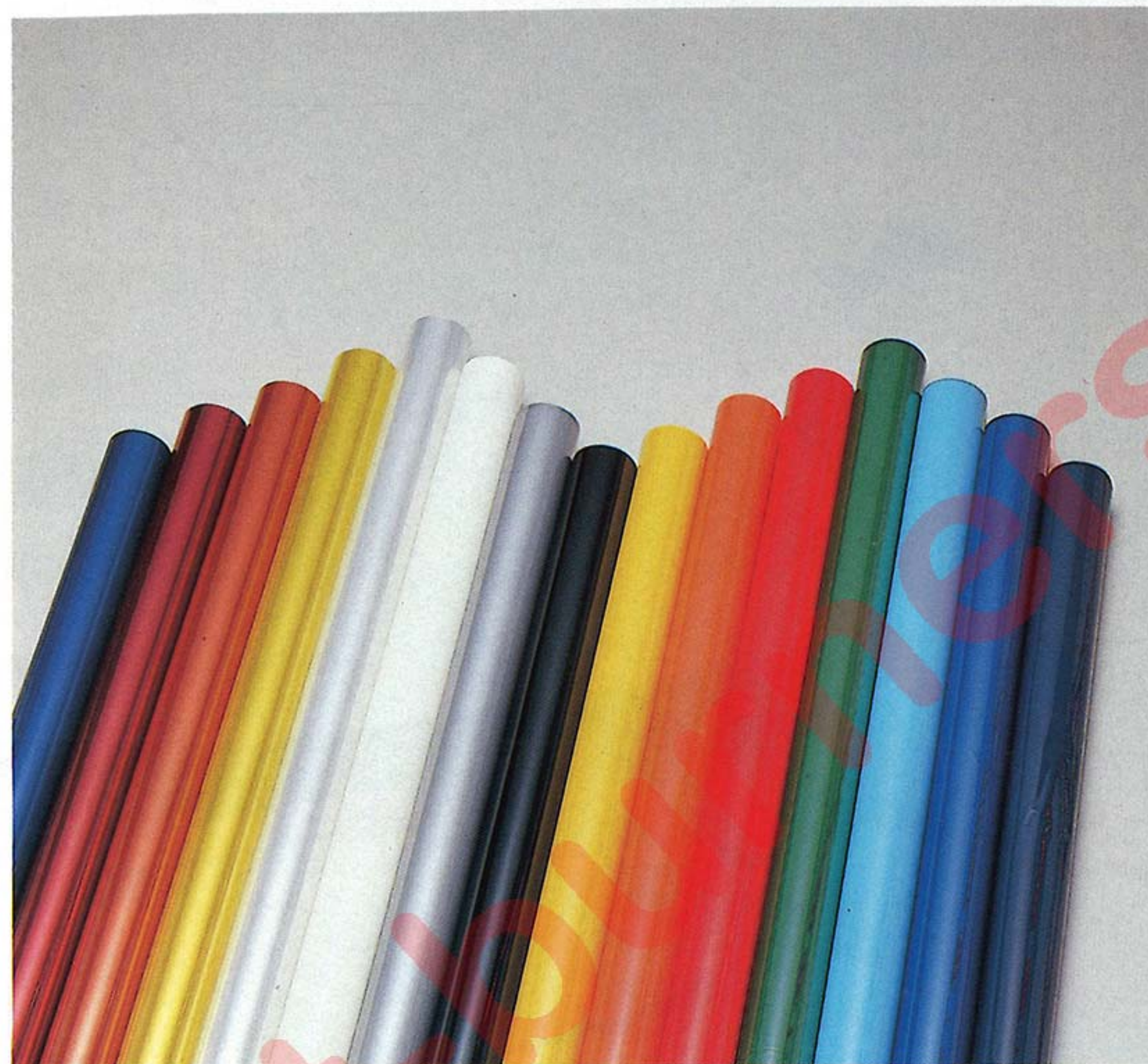

**EXCELCOTE  
GIVE YOUR FAVORITE AIRPLANE A PERFECT  
FINISH.**

EXCELCOTE IS A SPECIAL KIND OF FILM (POLY-ESTER) WHICH WILL RELIEVED YOU FROM THE COMPLEXITY OF COVERING YOUR AIRPLANE WITH SILK AND FURTHERMORE, IT GIVES A BETTER GLOSSY FINISH THAN A REAL PAINTED FINISH. HAS DURABILITY AND IS FUEL PROOF.

**DONNEZ À VOTRE MODÈLE UNE FINI-  
TION SUPER.**

EXCELCOTE EST UN FILM D'ENTOILAGE À BASE DE POLYESTER, ÉLIMINANT TOUS LES TRAVAUX FASTIDIEUX D'ENTOILAGE AU PAPIER ET LA FINITION À LA PEINTURE. LA QUALITÉ DE FINITION EST MEILLEURE QU'UNE COUCHE DE PEINTURE. LE FILM EST DURABLE ET RÉSISTE À TOUS LES CARBURANTS.

1688-W	WHITE
-O	ORANGE
-Y	YELLOW
-R	RED
-G	GREEN
-SB	SKY BLUE
-RB	ROYAL BLUE
-TR	TRANS RED
-TY	TRANS YELLOW
-TO	TRANS ORANGE
-MB	METALIC BLUE
-TB	TRANS BLUE
-BK	BLACK
-S	SILVER
-C	CLEAR

● SIZE : W 650 X L 1,800mm



# SILKYCOTE

## COVERING MATERIALS

NO.2150 • 2200



EXCI-COTE EST UN FILM D'ENTOILAGE  
 À BASE DE POLYESTER ÉLIMINANT  
 TOUTS LES TRAVAUX FASTIDIEUX  
 D'ENTOILAGE AU PAPIER ET LA FINI-  
 TION SUPER.  
 DONNEZ À VOTRE MODÈLE UNE FINI-  
 TION SUPER.



**COVERING CLOTH THAT CAN BE IRONED ON.**  
 SILKYCOTE IS A SILK TEXTURE COVERING  
 CLOTH THAT CAN BE IRONED ON. IT HAS  
 ADDED A SILK FINISH TO THE CONVENTIONAL  
 FILMS. IT CAN BE IRONED ONTO CURVED  
 SURFACES OF THE FUSELAGE AND AS IT HAS  
 CERTAIN AMOUNT OF SHRINK AND STRETCH  
 CAPABILITY IT IS EASY TO PUT ON. ALSO, IT IS  
 HARD TO LOOSEN OR WRINKLE ONCE IT IS  
 IRONED ON. FURTHERMORE, AS A SPECIAL  
 TREATMENT HAS BEEN APPLIED ON THE SUR-  
 FACE, FUEL, EXHAUST FUMES AND MUD CAN  
 BE EASILY REMOVED. SEVEN (7) COLORS ARE  
 AVAILABLE.

### TISSU À ENTOILER THERMOACTIF

LE SILKYCOTE EST UN TISSU D'ENTOILAGE  
 POUVANT ÊTRE APPLIQUÉ AU FER  
 À REPASSER. CONTRAIREMENT AUX  
 FILMS PLASTIQUES IL S'AGIT DONC  
 D'UN TEXTILE, MAIS IL S'APPLIQUE  
 AUSSI BIEN SUR LES COURBES. LA  
 CHALEUR DU FER À REPASSER ASSURE  
 SIMULTANÉMENT LE RÉTRÉCISSEMENT  
 ET LE COLLAGE DU TISSU. L'ADHÉSION  
 DU PRODUIT EST ABSOLUE ET SON  
 RÉTRÉCISSEMENT PERMANENT. GRÂCE  
 AU TRAITEMENT SPÉCIAL DE LA FACE  
 SUPÉRIEURE LE PRODUIT EST FACILE À  
 NETTOYER, ET IL EST INSENSIBLE AUX  
 CARBURANTS. DISPONIBLE EN 7 COU-  
 LEURS DIFFÉRENTES.





**K&B PAINT**  
MADE IN USA

## COATING POXY EPOXY COATING AND ADHESIVE RESIN



- ① NO.8150 K & B POLYESTER RESIN
  - ② NO.8151 K & B POLYESTER RESIN HARDENER
  - ③ NO.8163 K & B MICRO-BALLONS FILLER
  - ④ NO.8172 K & B MEASURING MIXING CUPS
  - ⑤ NO.8121 K & B SUPER POXY THINNER
  - ⑥ SUPER POXY
  - ⑦ NO.1039 MIDWEST MICROGLAS
- FOR JAPANESE MARKET ONLY



No.1884 COATING POXY

### ● FOR JAPANESE MARKET ONLY EPOXY COATING AND ADHESIVE RESIN.

COATING POXY has been formulated specially to provide a foundation for the highest quality on any model. It is noteworthy for its very low viscosity that brushes into a thin layer. When cured it has a beautiful glossy, strong, and fuel-proof finish. Here are some of the uses that we can suggest. You will think of many more!

### COATING ÉPOXY ET RÉSINE ADHÉSIVE.

COATING POXY EST UNE RÉSINE ÉPOXY DESTINÉE À SERVIR DE COUCHE DE BASE EN VUE DE LA FINITION DE TOUS LES MODÈLES. GRÂCE À SA FAIBLE VISCOSITÉ ELLE PEUT ÊTRE APPLIQUÉE AU PINCEAU. APRÈS DURCISSEMENT LA RÉSINE A UN ASPECT BRILLANT, DUR, RÉSISTANT ET INSENSIBLE AUX CARBURANTS.



**SPECIAL PROP DRIVE UNITS "360PT," "240S,"**  
**SPECIALLY DESIGNED FOR ELECTRIC POWERED AIRCRAFT MODELS**

(360PT) NO.4075 • 8000  
 (240S) NO.4076 • 7500



■ **SPECIAL PROP DRIVE UNITS**

KYOSHO OFFERS TWO HIGH-PERFORMANCE DRIVE UNITS OPTIMALLY DESIGNED FOR POWERING ELECTRIC AIRCRAFT MODELS WITH A 7.2V NiCd CAR-TYPE BATTERY PACK. MODEL 360PT IS DESIGNED FOR A MOTOR RUN OF 4-6 MINUTES WITH HIGH-TORQUE OUTPUT. MODEL 240S RUNS 2-3 MINUTES AT HIGHER SPEED FOR HIGH-HORSEPOWER, TOP SPEED REQUIREMENTS. BOTH UNITS ARE COMPLETE AND READY TO INSTALL IN A MODEL, COMPRISING A HIGH-QUALITY KYOSHO MOTOR (360PT OR 240S), A GEAR UNIT WITH RATIOS SELECTED FOR BEST PERFORMANCE FROM THE MOTOR/PROPELLER COMBINATION, A SPECIAL 9-4 WIDE-BLADE PROPELLER DESIGNED FOR BEST PERFORMANCE WITH ELECTRIC MOTORS, WIRING, A SWITCH, A BATTERY CONNECTOR AND A SPINNER.

KYOSHO PRODUIT DEUX TYPES DE RÉDUCTEURS DE PROPULSION POUR LES AVIONS ÉLECTRIQUES EN COMBINAISON AVEC DES BATTERIES DE 7,2 VOLTS. LE TYPE 360PT EST CONÇU POUR UNE DURÉE DE 4 À 6 MINUTES DE FONCTIONNEMENT À COUPLE ÉLEVÉ, ALORS QUE LE TYPE 240S EST PLUS PUISSANT MAIS AVEC UNE AUTONOMIE RÉDUITE À 2-3 MINUTES. LES DEUX TYPES SONT COMPLETS ET PRÊTS À ÊTRE INSTALLÉS; ILS COMPRENNENT UN MOTEUR KYOSHO DE HAUTE QUALITÉ (360PT OU 240S), LE RÉDUCTEUR À ENGRENAGES POUR LE MEILLEUR RENDEMENT DE L'ENSEMBLE MOTEUR + HÉLICE, UNE HÉLICE SPÉCIALE 9-4 À PALES LARGES, L'INTERRUPTEUR, UN CONNECTEUR DE BATTERIE ET LE SPINNER.

LeMANS AP29 NO.1929 • 1600

HIGH-TORQUE, WIDE USE TYPE, SUITABLE FOR MODEL AIRPLANES AND BOATS.



LeMANS AP29BB NO.1930 • 2500

SPECIAL HIGH-PERFORMANCE MOTOR FOR AIRCRAFTS AND BOATS.







**THE FIRST CHOICE IN TWO-STICK CAR RADIOS!**

COMFORTABLE TO HOLD, PRECISE IN CONTROL. THAT'S IMPULSE III! THIS TWO-CHANNEL SET INCLUDES TWO SERVOS AND ELECTRONIC SPEED CONTROLLER. HAS TRIMS AND SERVO REVERSING.

**LE PREMIER CHOIX EN RADIOS À DEUX STICKS!**

ÉMETTEUR PRATIQUE ET PRÉCIS: VOICI L'IMPULSE III! L'ENSEMBLE COMPREND DEUX SERVOS ET UN VARIATEUR ÉLECTRONIQUE. L'ÉMETTEUR EST POURVU DE TRIMS ET DES INVERSEURS DE SENS DE ROTATION DES SERVOS.





## THE RADIOS FOR THE EXPERTS

"PISTOL" STYLE TRANSMITTER FOR COMFORTABLE HANDLING AND PRECISE CONTROL. ADJUSTABLE FOR RIGHT OR LEFT HAND USE. BALANCE PREVENTS WRIST FATIGUE. CIRCUIT ELIMINATES CROSS-MODULATION PROBLEMS. SERVO REVERSE ON BOTH CHANNELS. (EXP2001: ALSO EXPONENTIAL AND END-POINT ADJUST.) USES CONVENTIONAL OR NiCd CELLS (NOT SUPPLIED). WITH AP-2R RECEIVER AND TWO AF-30S SERVOS.

## LA RADIO DES EXPERTS

ÉMETTEUR ERGONOMIQUE GRÂCE À SA CONCEPTION 'RÉVOLVER'. RÉGLABLE POUR LES GAUCHERS COMME POUR LES DROITIERS. L'ÉQUILIBRAGE PARFAIT EXCLUT TOUTE FATIGUE DU POIGNET. CIRCUIT SPÉCIAL CONTRE LA MODULATION CROISÉE. INVERSEUR DU SENS DE ROTATION POUR LES DEUX SERVOS (LE MODÈLE EXP 2001 DISPOSE EN PLUS DE LA COMMANDE EXPONENTIELLE ET DE LIMITATEURS DE COURSE). ALIMENTATION PAR PILES CONVENTIONNELLES OU NiCad (NON COMPRIS). FOURNI AVEC RÉCEPTEUR AP-2R ET DEUX SERVOS AP-30S.

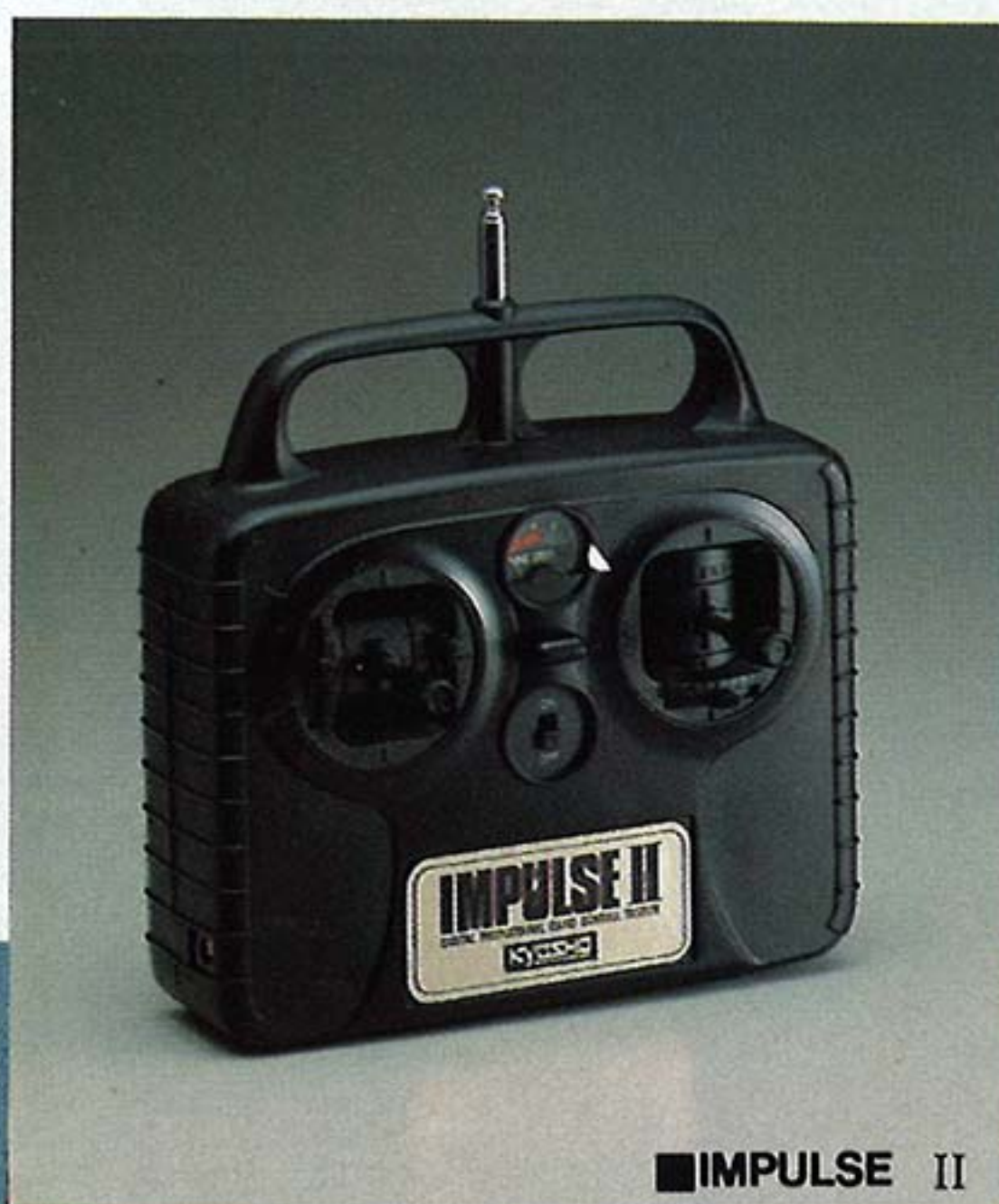

■ IMPULSE II



■ PULSAR PRO 2000



■ PULSAR EXP 2001

Alfa Romeo  
RAGE St CHRISTOPHE  
Gambetta-GRENOBLE-C : (76) 87/50/71

MARTINI





# KYOSHO ORIGINALS



- KYOSHO ORIGINAL CAP NO.4108
- KYOSHO ORIGINAL T-SHIRT (M.L) NO.4111
- KYOSHO VIDEO TAPES (NO.1~NO.12)
- R/C CHAIR BAG (M) NO.4114
- R/C CHAIR BAG (L) NO.4124
- R/C BAG NO.4125
- PARTS BOX (M) NO.4138
- PARTS BOX (S) NO. 4137
- TOOL BOX NO.4139
- NOTEBOOK NO.4173
- PEN STAND NO.4171
- LeMANS KEY HOLDER NO.4136
- CUTTING MAT NO.4122
- MEMO PAD NO.4170
- MAGNIFIER NO.4130
- CARD TYPE MINI CALCULATOR NO. 4174
- A SET SQUARE (TRIANGLE) NO.4123
- VINYL POUCH NO. 4172
- FREE BAG NO. 4126
- "KYOSHO" LOGO-TYPED STICKERS
- SUN CAP NO.4117
- BANNERET NO.4140
- VINYL BAG NO.4128
- DESIGNED PAPER BAG NO.4127
- AWARD PLAQUE (S) NO.4147 (M) NO.4148
- BANNER FOR COURSE WAY NO.4144 ●300
- RACING NUMBERED BIBS  
(NO.1~NO.50) NO.4145 (NO.1~NO.150) NO.  
4146B
- APPLICATION CARDS FOR ENTRIES
- RACING NUMBERS FOR CARS
- "KYOSHO" LOGO-TYPED BANNER
- "KYOSHO" LOGO-TYPED BANNERS WITH  
ROPE
- BANNERET



● KYOSHO ORIGINAL CAP NO.4108

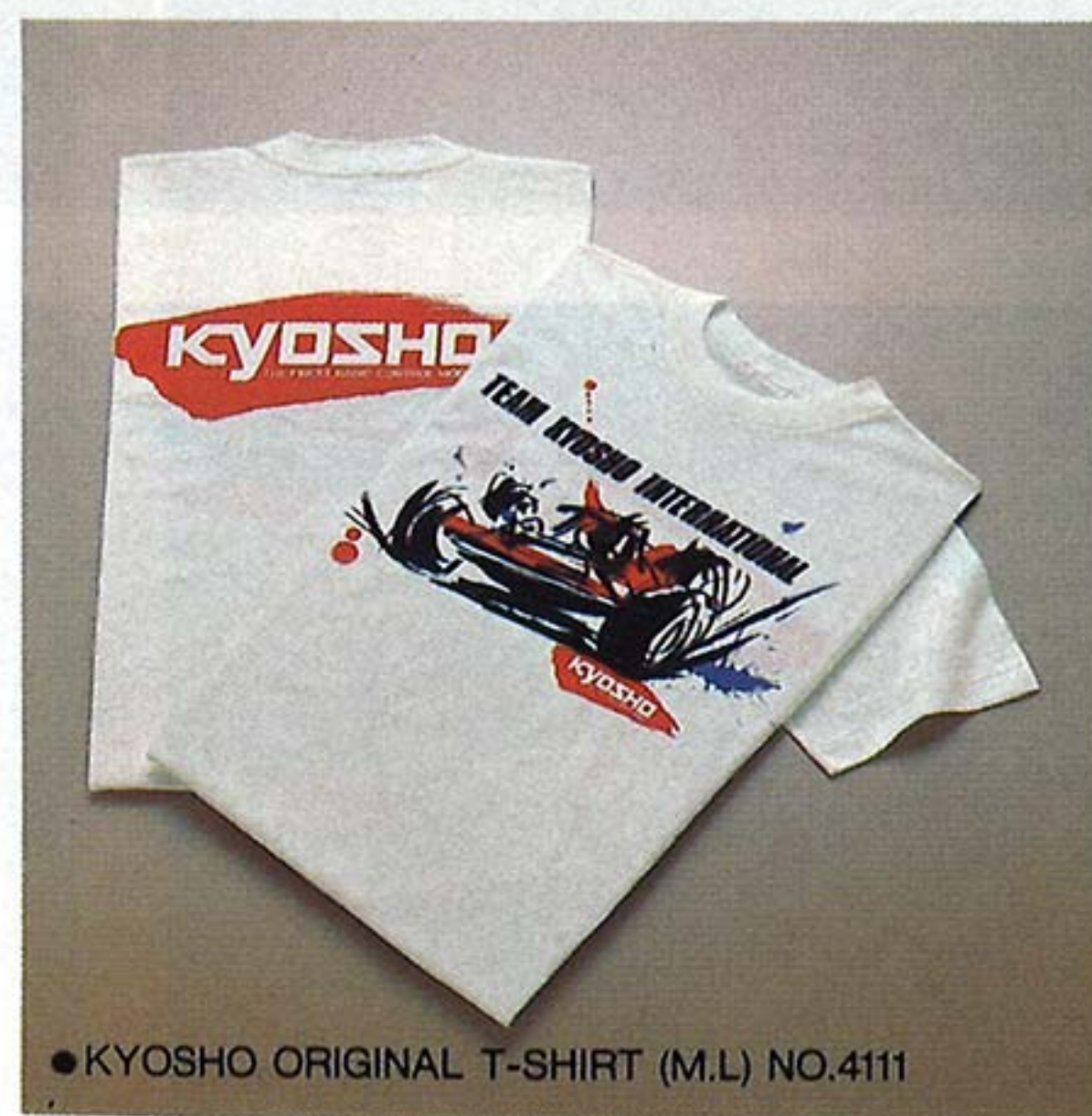

● KYOSHO ORIGINAL T-SHIRT (M.L) NO.4111



# KYOSHO ORIGINALS



- R/C CHAIR BAG (M) NO.4114
- R/C CHAIR BAG (L) NO.4124



- R/C BAG NO.4125



- TOOL BOX NO.4139

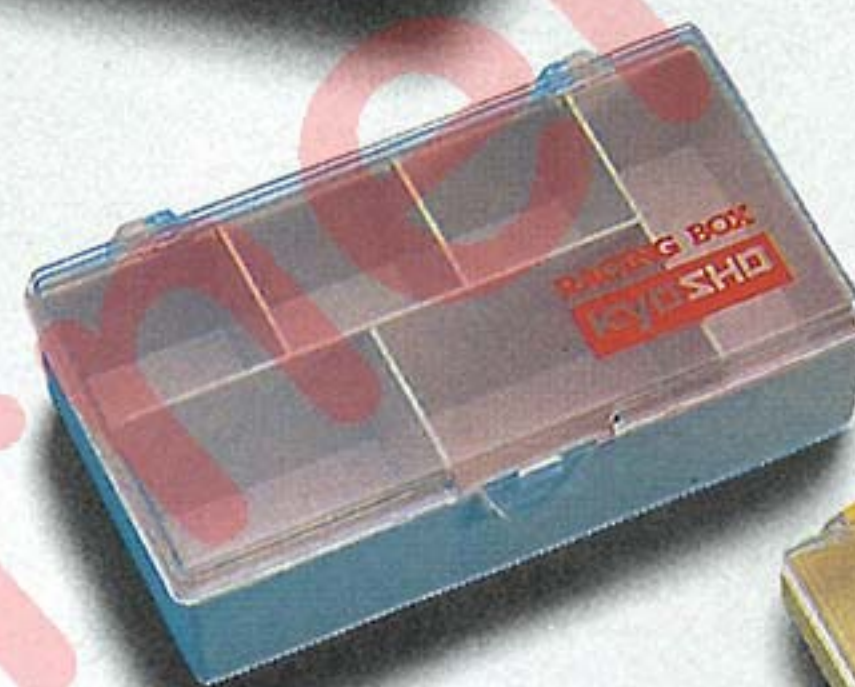

- PARTS BOX (M) NO.4138



- PARTS BOX (S) NO. 4137

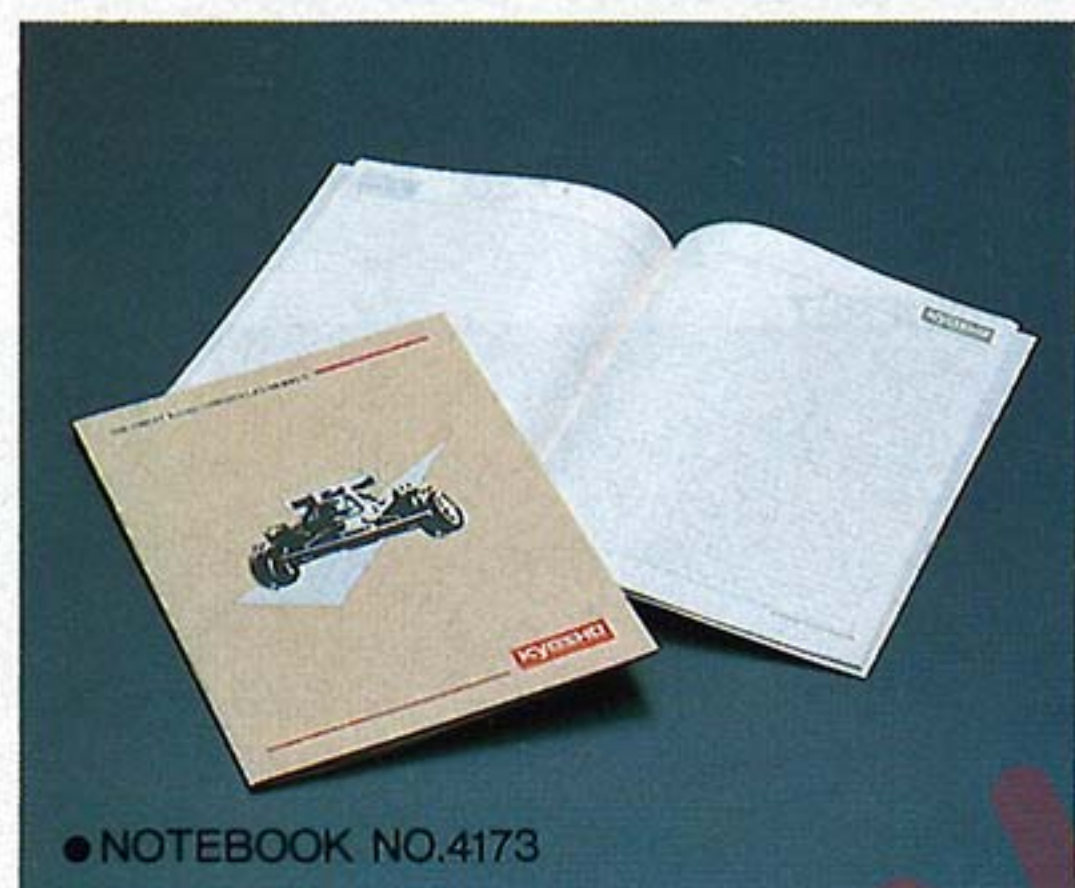

- NOTEBOOK NO.4173

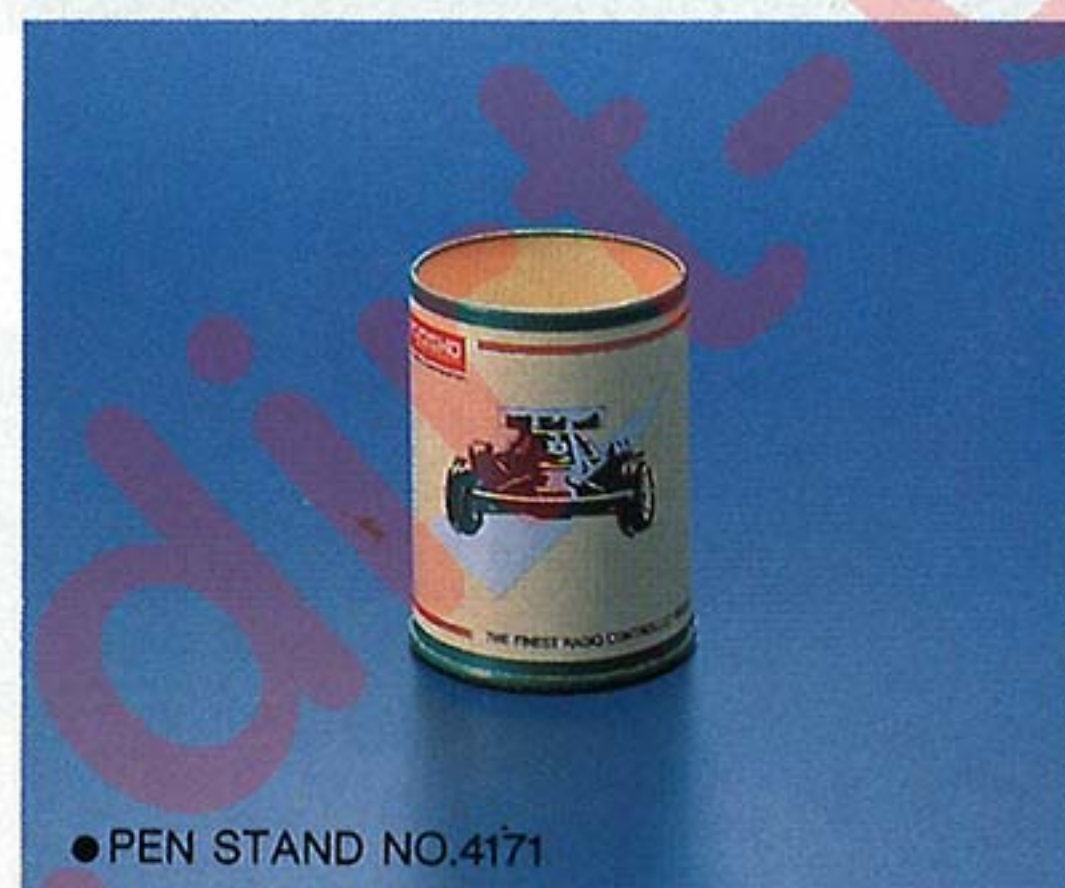

- PEN STAND NO.4171

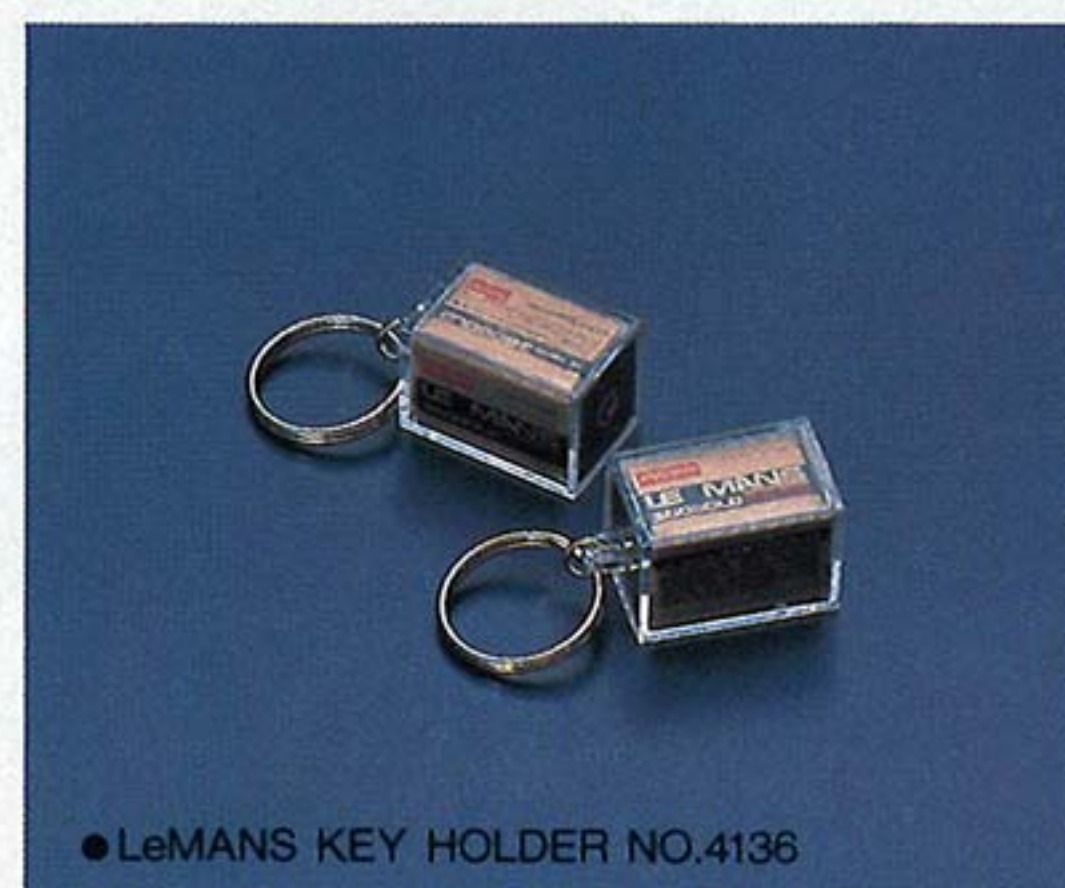

- LeMANS KEY HOLDER NO.4136

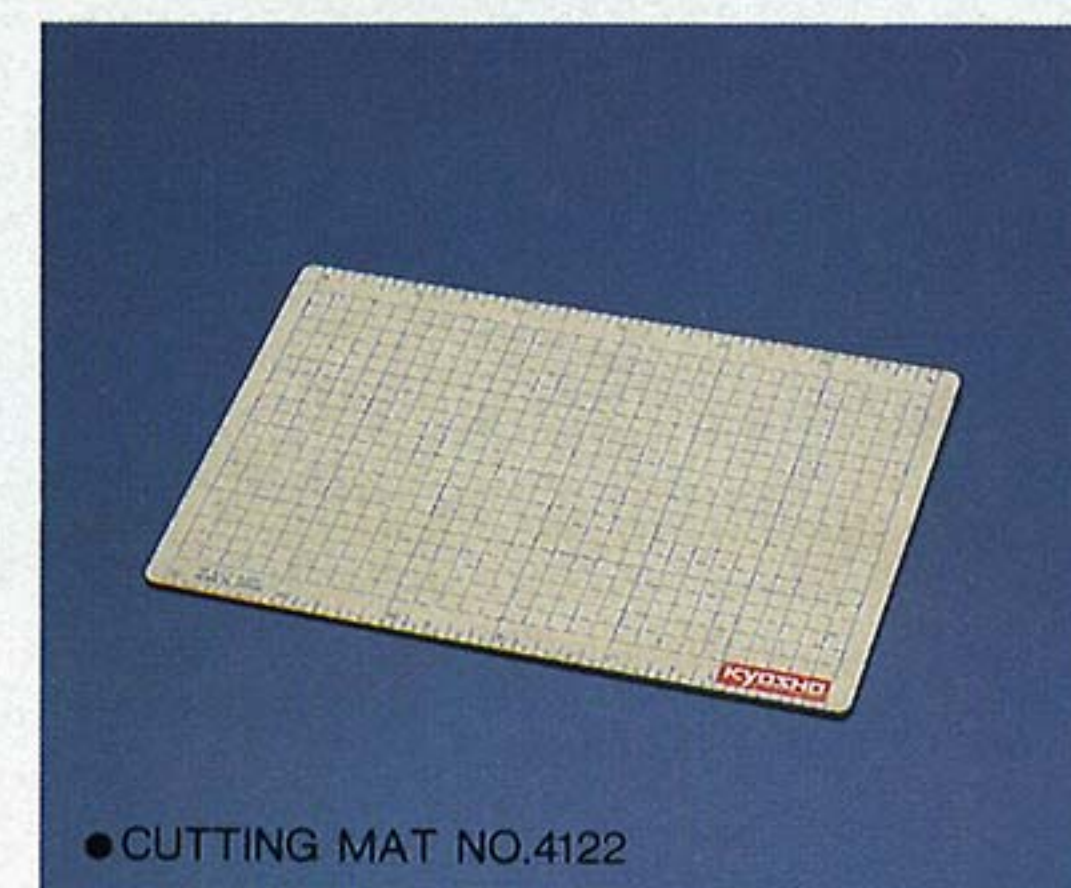

- CUTTING MAT NO.4122



- MEMO PAD NO.4170

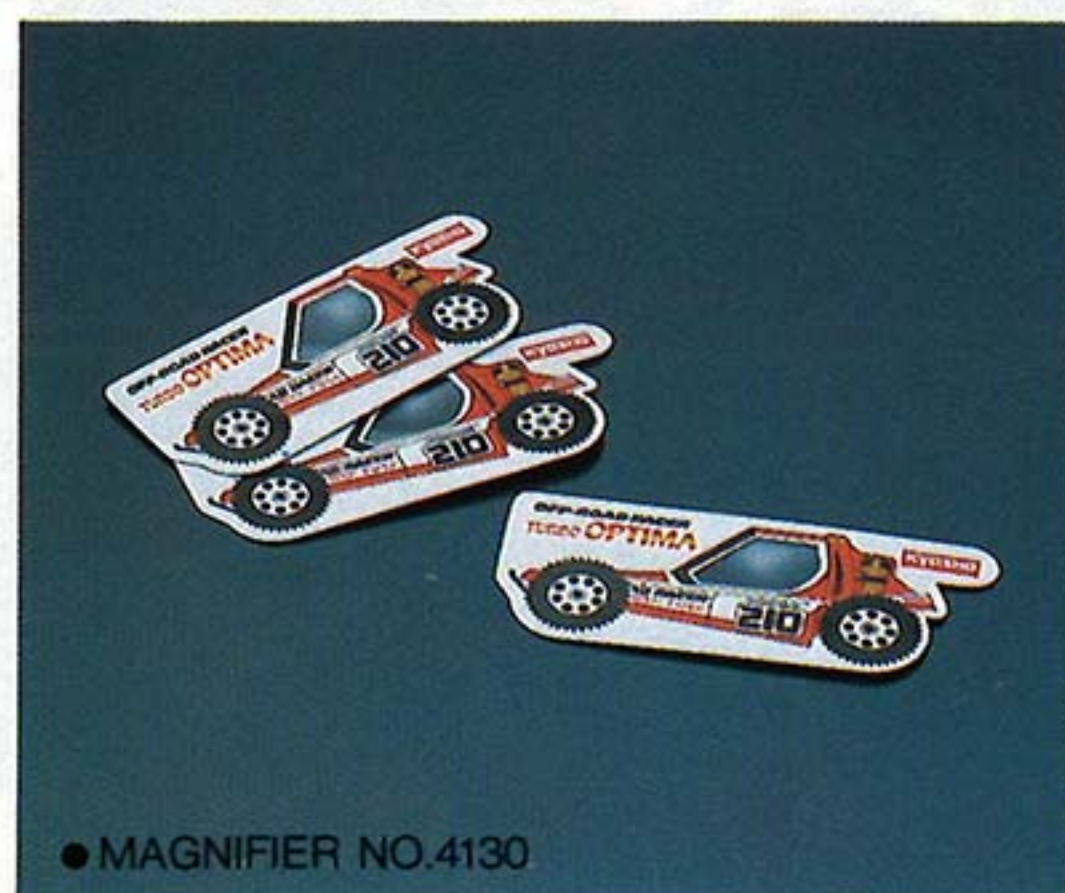

- MAGNIFIER NO.4130

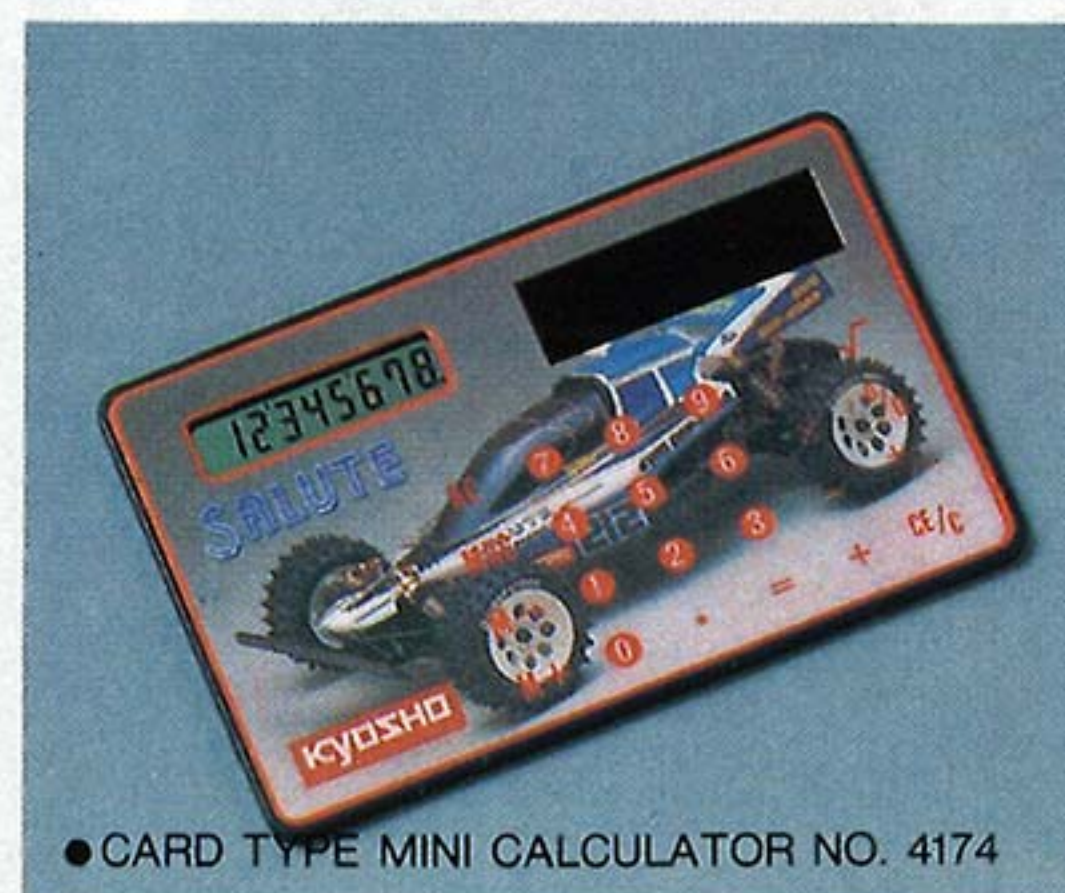

- CARD TYPE MINI CALCULATOR NO. 4174

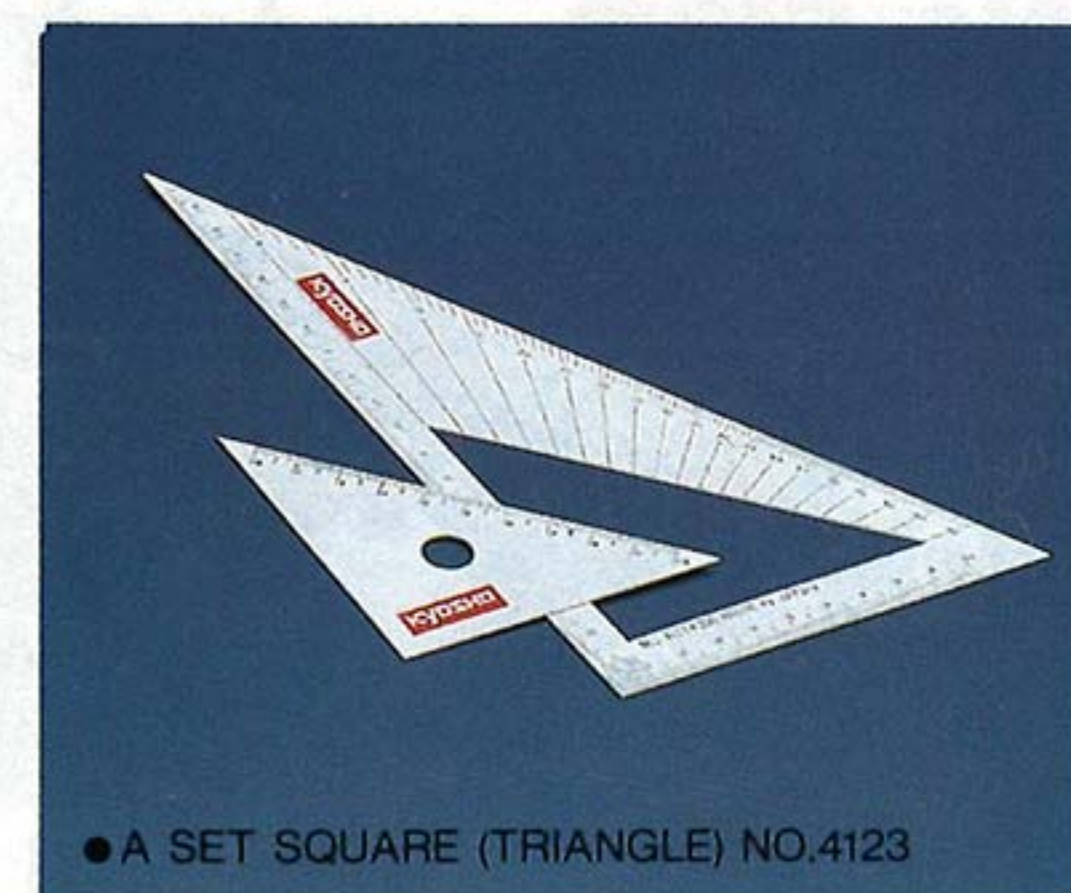

- A SET SQUARE (TRIANGLE) NO.4123





● VINYL POUCH NO. 4172



● FREE BAG NO. 4126



● "KYOSHO" LOGO-TYPED STICKERS

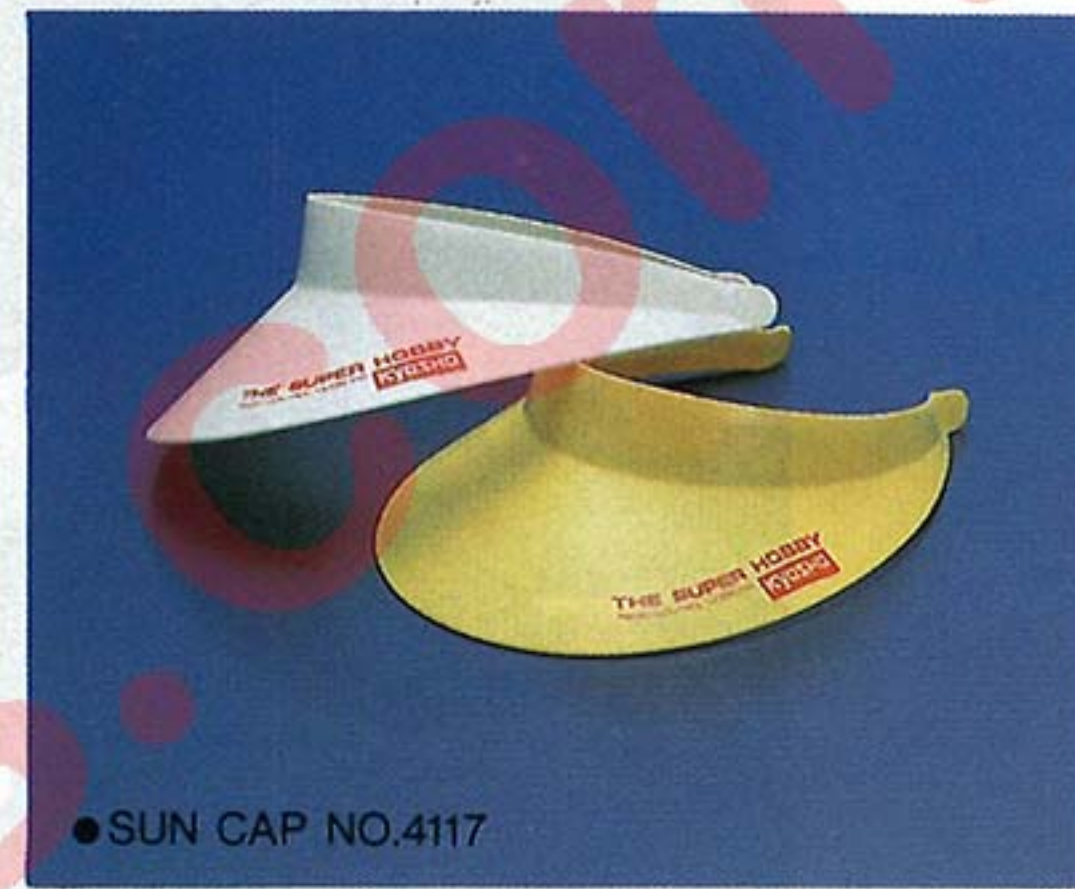

● SUN CAP NO.4117



● BANNERET NO.4140



● DESIGNED PAPER BAG NO.4127

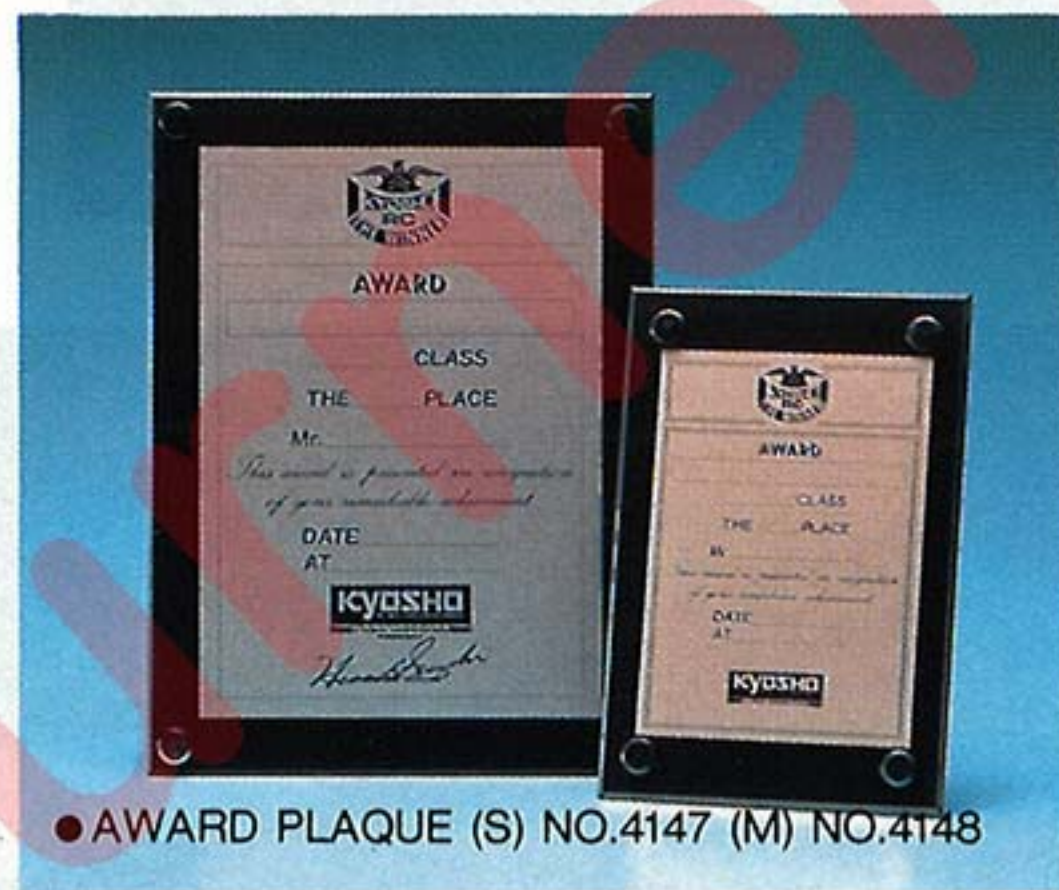

● AWARD PLAQUE (S) NO.4147 (M) NO.4148

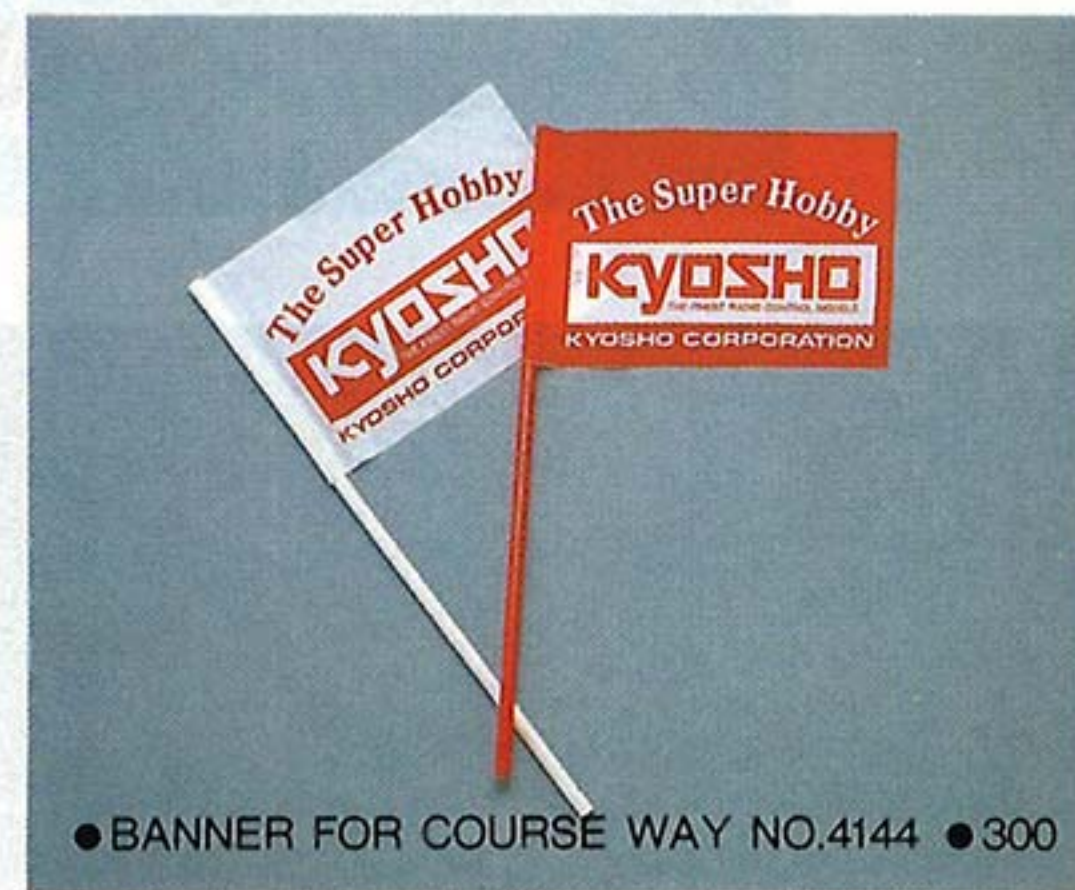

● BANNER FOR COURSE WAY NO.4144 ● 300

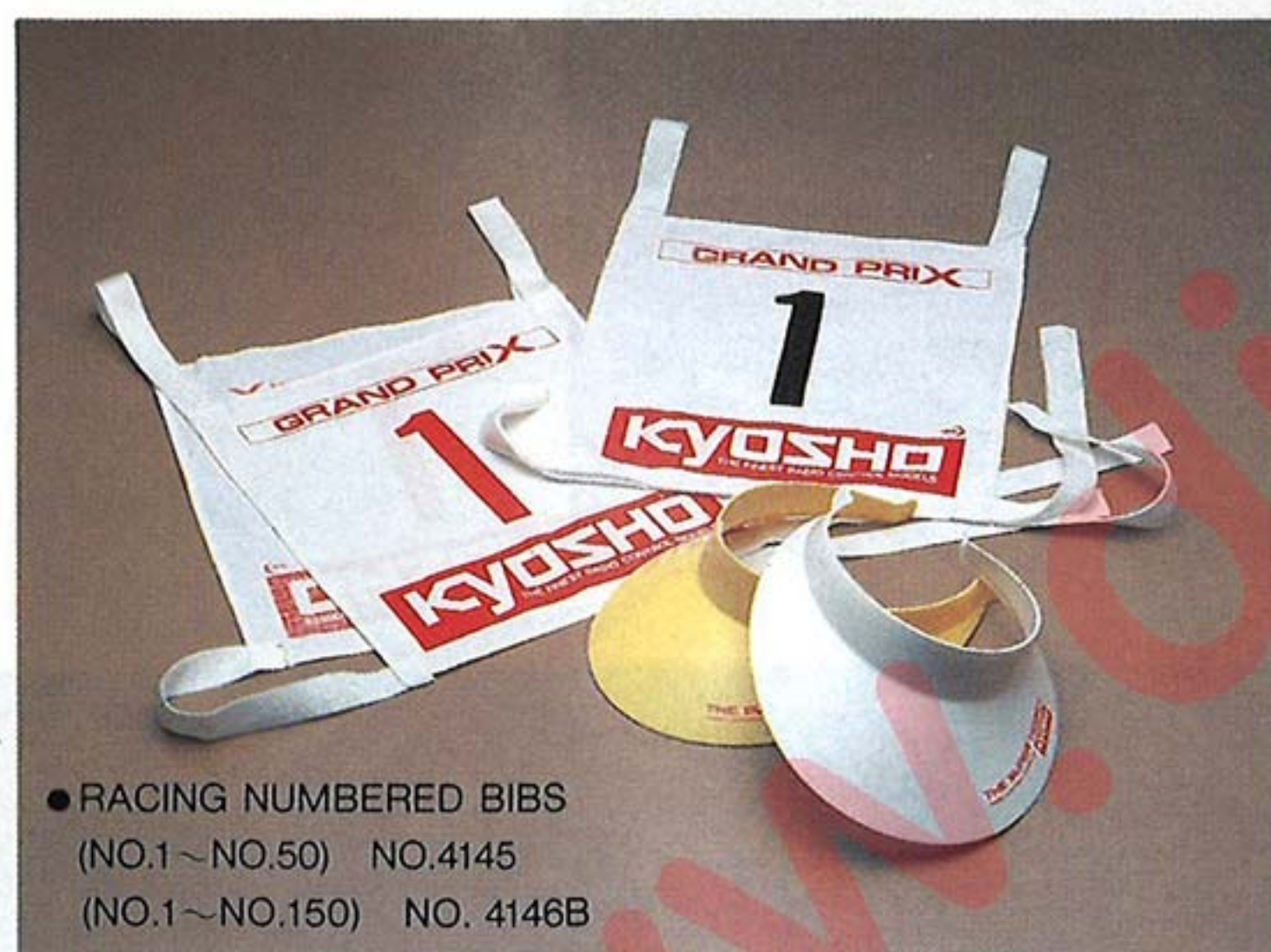

● RACING NUMBERED BIBS  
(NO.1~NO.50) NO.4145  
(NO.1~NO.150) NO. 4146B



● APPLICATION CARDS FOR ENTRIES



● "KYOSHO" LOGO-TYPED BANNER

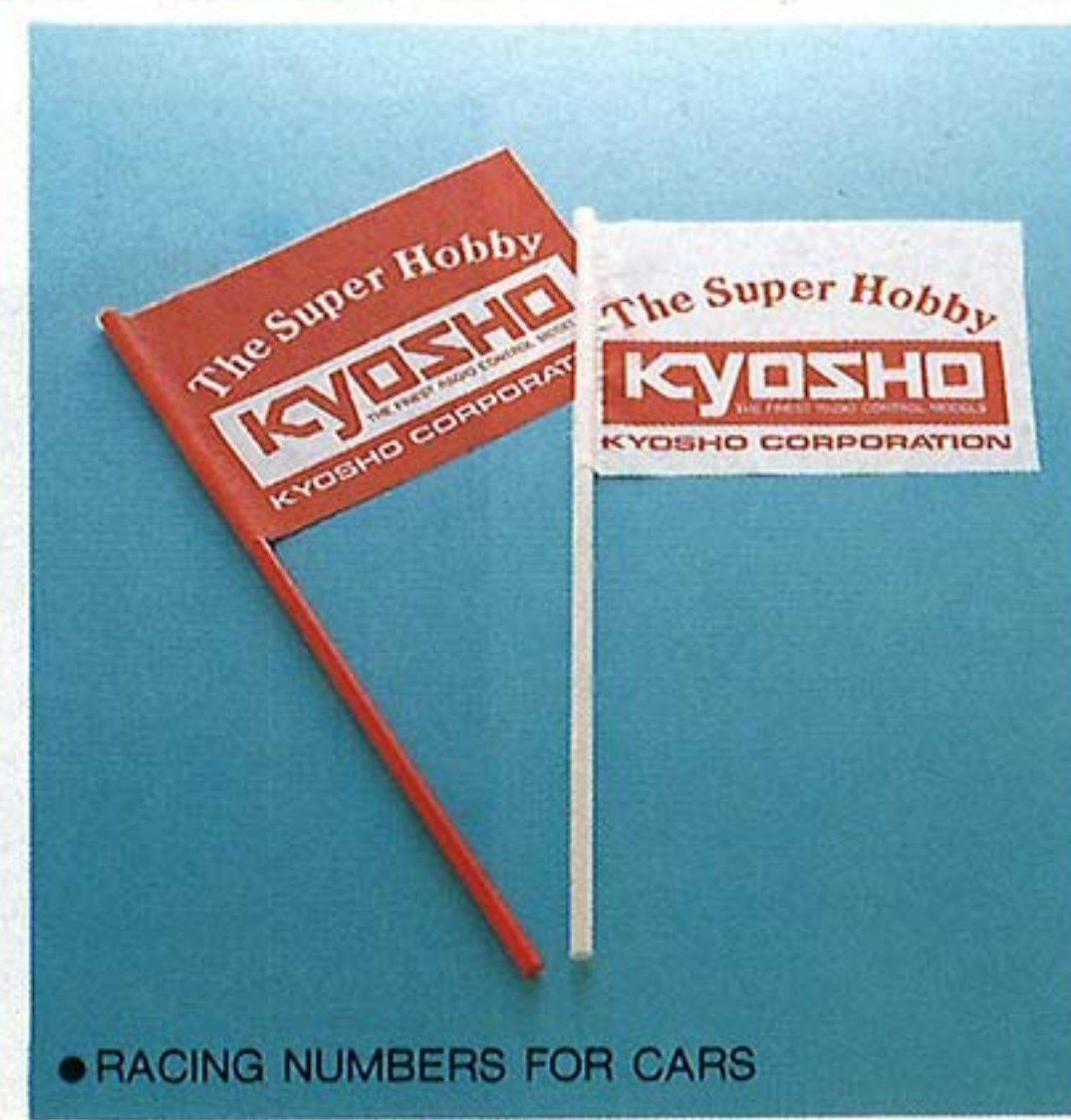

● RACING NUMBERS FOR CARS



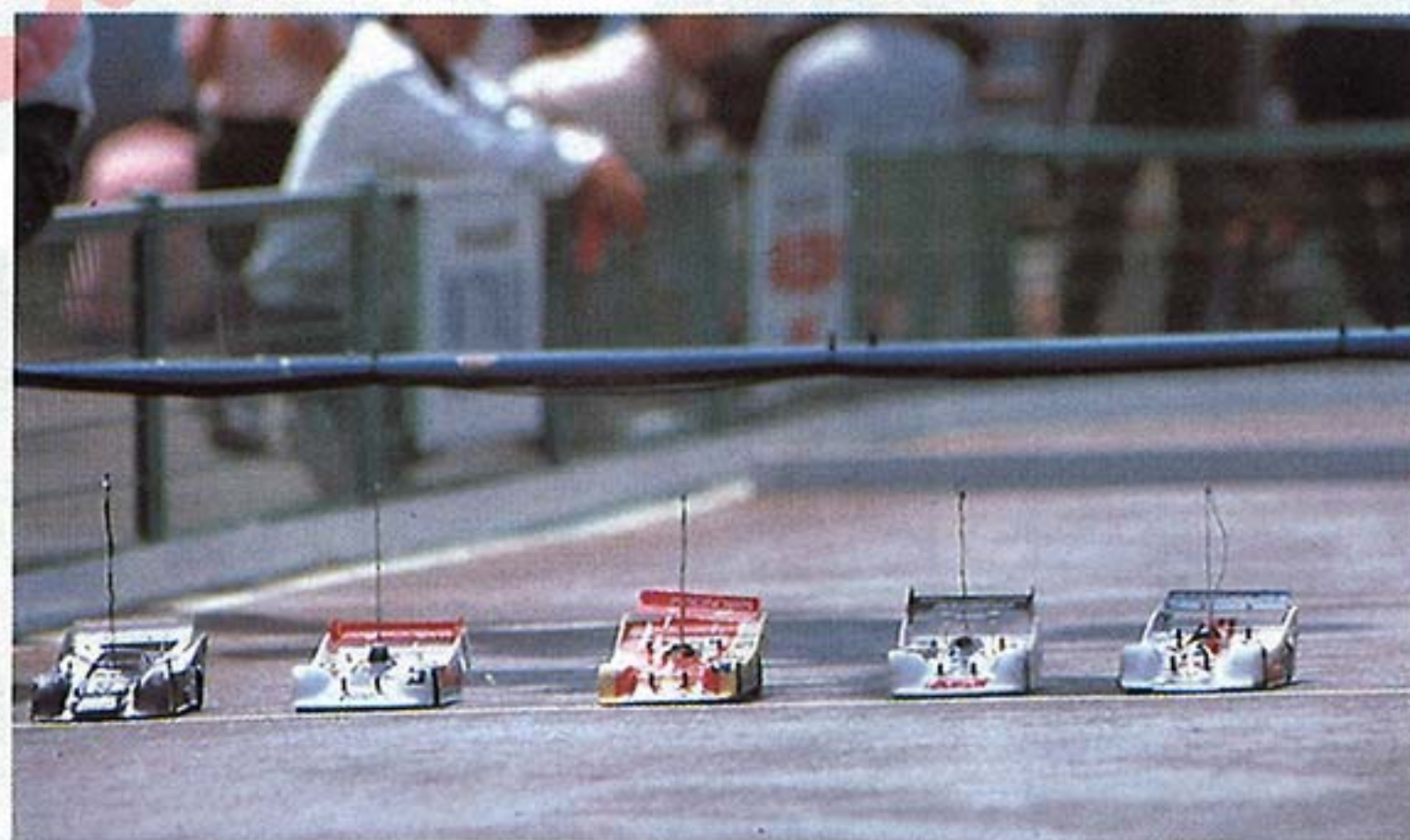
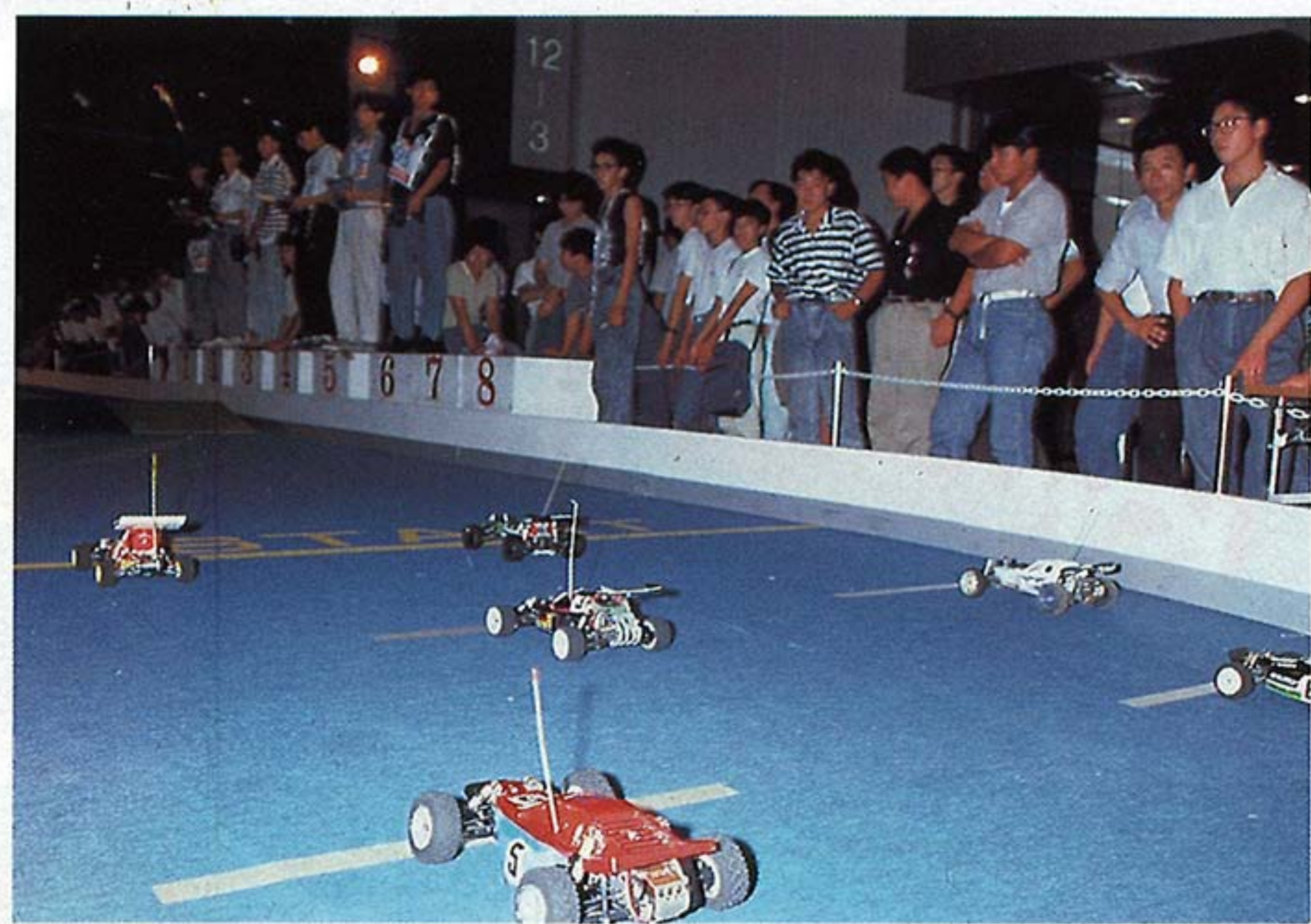





■ HEAD OFFICE



■ ATSUGI OPERATION CENTER





**KYOSHO**  
THE FINEST RADIO CONTROL MODELS

®

**KYOSHO CORPORATION**

**ATSUGI OPERATION CENTER**

153, FUNAKO NAGAKA-MACHI, ATSUGI, KANAGAWA 243, JAPAN

TELEFAX: 0462-29-5033 TELEX: J47979 KYOSHO TELEPHONE: 0462-29-1511

**HEAD OFFICE**

1-9-3 HIRAKAWA-CHO, CHIYODA-KU, TOKYO 102, JAPAN TELEPHONE: 03-264-4111



# PRISLISTE FOR KYOSHO HOVEDKATALOG 1988 Gyldig fra 1.1.1988

Denne prislisten er ment som en veiledning for våre kunder, og inneholder cirka priser hos norske forhandlere. Prisene kan variere noe fra forhandler til forhandler. Produkter du finner i hovedkatalogen, men ikke i prislisten importeres ikke til Norge. Har du ingen forhandler der du bor, kontakt Kyosho Norway, og vi kan opplyse deg hvor din nærmeste forhandler er.

Vare nr.	Varebeskrivelse	Kat.side	Stk. pris
<b>Elektro banebiler 1:12</b>			
3151	Plazma MK III, KS-2	55	1434.-
3152	Plazma MK III, LIMITED u/motor	55	2326.-
3074	EP Fantom 4WD EXT. SPIDER	57	2096.-
3075	EP Fantom 4WD EXT. CRC II	57	2096.-
<b>Elektro Street-Racer 1:12</b>			
3171	Honda CR-X	53	1162.-
3172	Peugeot	53	1230.-
<b>Elektro Off-Road Buggy's 1:10</b>			
3184	Raider 2WD	21	820.-
3082	Pegasus 2WD	23	900.-
3084	Cosmo 2WD	24	1070.-
3083	Icarus 2WD	25	1100.-
3115	Ultima 2WD	27	1450.-
3181	Shadow 4WD, Shaftdrive	33	1250.-
3101	Rocky 4WD	43	1530.-
3103	Turbo Rocky 4WD u/motor	47	1900.-
3069	Gallop MK-II 4WDS	45	1780.-
3032	Optima 4WD	41	1985.-
3031	Javelin 4WD	41	2020.-
3130	Turbo Optima 4WD	49	2660.-
3034	Salute 4WD u/motor	49	2375.-
3029	Optima Pro 4WD u/motor og reg.	35	1620.-
3135	Optima Mid 4WD	37	2330.-
3136	Turbo Optima Mid 4WD u/motor og reg.	38	2520.-
3105	Big Brute	19	1410.-
<b>Spesial elektromotorer LE MANS</b>			
1891	Le Mans 480S	120	380.-
1892	Le Mans 480T	120	380.-
1893	Le Mans 240S	121	380.-
1894	Le Mans 600E	121	192.-
1895	Le Mans 360PT	120	436.-
1897	Le Mans 480 GOLD	120	520.-
1898	Le Mans 360ST	121	192.-
1924	Le Mans 240SB	121	520.-
1925	Le Mans 360 GOLD	120	560.-
1926	Le Mans Sport H-240S	121	346.-
1929	Le Mans AP-29	121	156.-
1934	Le Mans DM-20	121	98.-
<b>Spesial elektromotorer SPA</b>			
W-1011	SPA 240WS	121	650.-
W-1012	SPA 480WT	121	650.-
<b>Batterier, ladere, el.utstyr</b>			
2205	NiCad pakke 6 Volt 450 mah	117	318.-
2218	Racing pakke (Sanyo) 7.2 Volt 1200 mAh	117	442.-
1932	Turbo Racing pakke (Sanyo) 8.4-1200	117	520.-
2306	Power pakke (Panasonic) 7.2-1200	117	324.-
2307	Power pakke (Panasonic) 8.4-1200	117	360.-
2365	6 Volt power lader m/timer, 450 mAh	119	238.-
2326	7.2 Volt power lader m/timer, 1200 mAh	119	240.-
2327	8.4 Volt power lader m/timer, 1200 mAh	119	240.-
1835	Powerdivider for «glowmodeller»	132	480.-
1843	7.2 Volt «HOOK»-kontakter, 1 par hun/han		22.-
1844	7.2 Volt hurtigladekabel m/klyper og plugg		84.-
1845	LAMBDA Hurtiglader, 4.8 - 8.4 Volt	119	900.-
1849	Hurtiglader m/utlader 4.8 - 8.4 Volt	119	590.-
1896	Motor Checker	122	630.-
1791	Blitz starter 12 Volt DC	132	500.-
BZ-1	Gummiring for start av biler		66.-
1825	Loddebolt 12 Volt DC, 18 Watt	130	270.-
1836	Motor innkjøringsenhet 12 Volt DC	122	450.-

Vare nr.	Varebeskrivelse	Kat.side	Stk. pris
<b>Elektro motorsykel 1:8</b>			
3002	Honda NSR 500 (styres med COMRAS)	9	740.-
2567	COMRAS for styring av motorsykel	15	860.-
<b>Elektro Baja-Bugs 1:20 + tilbehør</b>			
3191	Turbo Optima 2WD m/lader og batt.	11	980.-
3192	Ultima 2WD m/lader og batt.	11	980.-
3193	Salute 2WD m/lader og batt.	11	890.-
2312	Batteri for 1:20 minibiler 7.2V-270mAh	14	244.-
2332	7.2 Volt power lader m/timer, 270 mAh	14	244.-
1975	Kulelagersett (14 lager) for minibiler	14	390.-
3190	Banesett for 1:20 og 1:10 biler	13	3650.-
3199	Startsignal m/rød, gul og grønn lampe	13	950.-
2566	COMRAS for styring av Baja-Bugs	15	860.-
<b>Off-Road biler — Glow-motor</b>			
3039	Racing Pajero 2WD m/motor 1:12	63	2135.-
	NITRO BRUTE 2WD m/motor 1:10	19	2590.-
3095	ASSAULT 2WD m/motor 1:10	66	2780.-
3041	STINGER 4WD m/motor 1:10	64	2983.-
3042	STINGER MK-II 4WD m/motor 1:10	65	3170.-
3058	VANNING 4WD u/motor 1:8	67	3591.-
3059	PRESTO 4WD u/motor 1:8	67	3528.-
3096	Burns 4WD u/motor 1:8	69	4316.-
<b>Båter — elektromotor</b>			
2265	Jackson outboard motor RS380	112	338.-
2266	Jackson outboard motor RS540	112	378.-
2267	Florida med Jackson RS380	111	1130.-
2409	Casablanca med dobbel Jackson	112	1390.-
2430	Tom's River elvebåt	110	938.-
<b>Seilbåter</b>			
2252	Riviera yacht	113	938.-
3421	Fair-Wind yacht	115	1698.-
Y-08	2 kg ballast for Fair-Wind		230.-
<b>Fly — Glowmotor</b>			
4035	Patricia 10 m/OS 10FSR motor	4	2375.-
4061	Cessna Skyhawk 172	97	2365.-
4062	Bellanca Super Decathlon	97	2365.-
4066	Cessna Skyline 182 m/.049 COX motor	92	1550.-
4078	Prelude 10 m/OS 10FSR motor	96	2195.-
4081	Prelude 20	96	1880.-
<b>Seilfly — Elektrofly</b>			
4031	Melody 1500 kompl. m/høystartstrikk	85	940.-
4032	Melody Motor Pylon m/motor, lader og batteri	86	1740.-
4033	Valencia 1800	80	1910.-
4036	Flash EP	79	1935.-
4071	Etude 1200	81	1695.-
4072	Duet 1200	82	1915.-
4089	Petit Ballad 950 m/motor, lader og batteri	75	1160.-
4091	Petit Breezin 1200 m/motor, lader og batteri	75	1620.-
4092	Petit Robin 850 m/motor, lader og batteri	75	1620.-
4093	Petit Dreamin 850 m/motor, lader og batteri	75	1620.-
<b>Super-Prop-unit for store elektrofly</b>			
4075	Prop drive unit 360PT	138	738.-
4076	Prop drive unit 240S	138	692.-
<b>Beltebil 1:12</b>			
2435	Blizzard	59	1850.-
2436	Utstyrsett for Blizzard		280.-



Ønsker du opplysning om hvor du har din nærmeste Kyosho forhandler, så skriv eller ring til:  
 KYOSHO NORWAY A.S. BOKS 480, 3101 TØNSBERG TLF. 033 - 65 775

## 3 GODE TIPS TIL DEG SOM ER MODELLBYGGER



- Når modellen er ferdig bygget ta alltid godt vare på byggebeskrivelsen. Dette er det beste hjelpemiddelet du har når du trenger reservedeler
- Når du trenger reservedeler, ta med deg byggebeskrivelsen til forretningen der du kjøpte modellen. Dette fører til raskere delekspedering, og du kan være sikrere på at du får den rette delen.
- Selger du din brukte modell til ny eier, så sørg for at du gir med byggebeskrivelsen. Da får også den nye eieren en sjanse til å skaffe seg reservedeler når uhellet er ute.

Har du ingen hobbyforhandler der du bor, kan du kontakte oss når det gjelder reservedeler:

KYOSHO NORWAY A.S.  
 BOKS 480  
 3101 TØNSBERG  
 TLF. 033 - 65 775

ALLE RESERVEDELER SOM  
 BESTILLES HOS  
 KYOSHO NORWAY A.S.  
 SENDES I OPPKRAV SAMME DAG!

Vare nr.	Varebeskrivelse	Kat.side	Stk. pris
<b>KYOSHO Reklame-materiell</b>			
4109M	T-Skjorte, medium	141	88.-
4109L	T-Skjorte, stor	141	88.-
4114	Stol-bag, liten	142	270.-
4117	Sol-skjerm av plast	143	18.-
4122	Skjæreplate	142	63.-
4123	Vinkel-linjål	142	16.-
4124	Stol-bag, stor	142	360.-
4130	Lupe	142	9.-
4136	Nøkkel-ring	142	9.-
4170	Notisblokk	142	16.-
4171	Blyanholder	142	16.-
4172	Plast-penal	143	16.-
4173	Notisbok	142	9.-
4108	Kyosho-caps	141	160.-
	Videofilmer		
4160	Kyosho Elektro Off-Road Buggies		225.-
4182	Kyosho Elektro fly, bil og båt		225.-
<b>«OPTION HOUSE» spesialdelar</b>			
W-0101	Motor beskytter for Optima-serien	124	74.-
W-0102	Side beskytter for Optima-serien	124	158.-
W-0103	Golden chassis sett for Optima-serien	124	320.-
W-0104	Spesial chassis for Optima-serien	125	282.-
W-0105	Belte ombyggingssett for Optima-serien	125	270.-
W-0106	En-veis clutch (belte) for Optima-serien	125	282.-
W-0107	Kulelagerdiff. front, Optima-serien		282.-
W-0108	Kulelagerdiff. bak, Optima-serien		304.-
W-0109	Kulelagerdiff. Ultima		282.-
W-1001	High Carbon plate (245x100x1,7 mm)	124	410.-
W-5001	Trykk oljestøtdemper, foran	124	282.-
W-5002	Trykk oljestøtdemper, bak	124	282.-
W-5003	Oljestøtdemper, justerbar, liten	125	282.-
W-5004	Oljestøtdemper, justerbar, stor	125	282.-
W-5005	Spesial stag sett	125	164.-
W-5009	Herdet piniondrev, 9T	124	54.-
W-5010	Herdet piniondrev, 10T	124	54.-
W-5011	Herdet piniondrev, 11T	124	54.-
W-5021	Lav profil felg, par, 50 mmo	124	78.-
W-5031	Lav profil dekk, Allround type 50 mmo	124	124.-
W-5032	Lav profil dekk, High grip type 50 mmo	124	124.-
W-5040	Racing clutch, 10T	124	204.-
W-5042	Racing clutch, 12T	124	204.-
W-5044	Racing clutch, 14T	124	204.-
W-5046	Racing clutch, 16T	124	204.-
W-5048	Racing clutch, 18T	124	204.-
W-5051	Belte ombyggingssett for STINGER	125	282.-
W-5061	Universal-ledd aksel for Optima/Ultima	125	234.-
W-5062	Universal-ledd aksel for Rocky/Raider	125	234.-
W-5085	Herdet piniondrev 15T	125	54.-
W-5086	Herdet piniondrev 16T	125	54.-
W-5087	Herdet piniondrev 17T	125	54.-
W-5088	Herdet piniondrev 18T	125	54.-
W-5089	Herdet piniondrev 19T	125	54.-
W-5090	Herdet piniondrev 20T	125	54.-
W-5091	Herdet piniondrev 21T	125	54.-
W-5092	Herdet piniondrev 22T	125	54.-
W-5093	Herdet piniondrev 23T	125	54.-
W-5094	Herdet piniondrev 24T	125	54.-
W-5095	Herdet piniondrev 25T	125	54.-

Vare nr.	Varebeskrivelse	Kat.side	Stk. pris
<b>Tilbehør, bildeler</b>			
1829	Spesialsaks og pussler for lexankarosseri	131	98.-
1841Y	Micron stripe tape, 1mmx5m, gul	131	28.-
1841R	Micron stripe tape, 1mmx5m, rød	131	28.-
1841BK	Micron stripe tape, 1mmx5m, svart	131	28.-
1841W	Micron stripe tape, 1mmx5m, hvit	131	28.-
1841BL	Micron stripe tape, 1mmx5m, blå	131	28.-
1841G	Micron stripe tape, 1,5mmx5m, grønn	131	28.-
1842Y	Micron stripe tape, 1,5mmx5m, gul	131	28.-
1842R	Micron stripe tape, 1,5mmx5m, rød	131	28.-
1842BK	Micron stripe tape, 1,5mmx5m, svart	131	28.-
1842W	Micron stripe tape, 1,5mmx5m, hvit	131	28.-
1842BL	Micron stripe tape, 1,5mmx5m, blå	131	28.-
1842G	Micron stripe tape, 1,5mmx5m, grønn	131	28.-
1843Y	Micron stripe tape, 2,5mmx5m, gul	131	28.-
1843R	Micron stripe tape, 2,5mmx5m, rød	131	28.-
1843BK	Micron stripe tape, 2,5mmx5m, svart	131	28.-
1843W	Micron stripe tape, 2,5mmx5m, hvit	131	28.-
1843BL	Micron stripe tape, 2,5mmx5m, blå	131	28.-
1841G	Micron stripe tape, 2,5mmx5m, grønn	131	28.-
1863	Selvklebende merker, 2 stk. A4-ark	127	58.-
1871	Swamp dekk for 40 mm felg, 1 par	127	124.-
1872	Swamp dekk for 50 mm felg, 1 par	127	124.-
1873	Gummi dekk med mønster 40 mm felg, 1 par	127	124.-
1874	Gummi dekk med knaster 40 mm felg, 1 par	127	124.-
1875	Gummi dekk fronthjul S-mønster 50 mm felg, 1 par	127	124.-
1881	Hard oil for diff. og gearkasse		58.-
1883	Frontier Hobby olje	127	146.-
1886	Støtdemper-sett		230.-
1887	Støtdemperpakk, 10 mm, 10 stk.mv/nækkel		16.-
1888	Støtdemperpakk, 12 mm, 10 stk.mv/nækkel		16.-
1901	Kulelager, 1 par, 50x100x4	126	80.-
1902	Kulelager, 1 par, 50x80x3 (ny for MID)		80.-
1903	Kulelager, 1 par, 40x80x3	126	80.-
1911	Kulelager, 1 par, 80x140x4	126	80.-
1951	Støtdemper-olje, 3 fl. soft-med.-hard	127	88.-
1952	Differensialolje	127	70.-
1953	Silicone-olje, soft, 2 flasker	127	126.-
1954	Silicone-olje, medium, 2 flasker	127	126.-
1955	Silicone-olje, hard, 2 flasker	127	126.-
1971	Kulelager-sett for Optima, Javelin, 12 lager	126	390.-
1972	Kulelager-sett for Rocky, 14 lager	126	452.-
1974	Kulelager-sett for Ultima, 14 lager	126	452.-
1990	Spenningsregulator 8,4 V batteri	127	76.-
2230Y	Polyca lexan making, gul	131	26.-
2230R	Polyca lexan making, rød	261	26.-
2230G	Polyca lexan making, grønn	261	26.-
2230BL	Polyca lexan making, blå	261	26.-
2230W	Polyca lexan making, hvit	261	26.-
2230O	Polyca lexan making, orange	261	26.-
2230V	Polyca lexan making, violet	261	26.-
2230SB	Polyca lexan making, himmelblå	261	26.-
2230YG	Polyca lexan making, gulgrønn	261	26.-
2230KO	Polyca lexan making, fluoriserende orange	261	26.-
2230KP	Polyca lexan making, fluoriserende rosa	261	26.-
2230BK	Polyca lexan making, svart	261	26.-
2240	Polyca salgs-stativ mv/12 farger, 132 glass	261	3600.-
4137	Deleboks, liten	142	24.-
4138	Deleboks, stor	142	36.-
4139	Verktøykasse	142	158.-
<b>KYOSHO HOVEDKATALOG 1988, 148 SIDER</b>			
			40.-
<b>RC-MANUAL. Norsk veiledning om RC biler og utstyr</b>			
			5.-

I tillegg til denne enkle deleoversikt, så inneholder vårt delerlager alle deler til alle biler vi lagerfører.

Vare nr.	Varebeskrivelse	Stk. pris
<b>Diverse reservedeler</b>		
EF-37	Nylon-strap, korte, pose med 6 stk	20.-
EF-38	Nylon-strap, medium, pose med 6 stk	34.-
EF-39	Ni-Cad straps, lange, pose med 6 stk	48.-
EF-103	Racing wire (Siliconekabel)	126 70.-
EP-22	Karosseri festekrok, små, pose med 5 stk	12.-
1889	Karosseri festekrok, store, pose med 5 stk	12.-
FF-30	Front lys sett 2 pærer, plugg og kabel	56.-
LM-05	Le-Mans børster, passer alle Le Mans motorer	34.-
LM-06	Endeløkk for motorer med kulelager	220.-
LM-07	Le-Mans børstefjærer	28.-
LM-08	Silicone ståring (øker magnetfeltet)	34.-
LM-15	Le-Mans motor kjeleplate	126 98.-
LM-18	Le Mans skruer, skiver, kondensator, etc.	60.-
LM-19	Anker for SPA 240WS	270.-
LM-2	Anker for SPA 480WT	270.-
LM-100	Kulelager for Le Mans og SPA motorer	96.-
MS-26	Kulelager 60x100x3 mm med flens, 1 par	126 220.-
OT-23	Pinion gear 12 tenner	126 30.-
OT-24	Pinion gear 15 tenner	126 30.-
OT-38	Silicone grease, 2 tuber	127 32.-
OT-50	Pinion gear 13 tenner	126 30.-
OT-51	Pinion gear 14 tenner	126 30.-
OT-52	Pinion gear 16 tenner	126 30.-
OT-53	Pinion gear 17 tenner	126 30.-
OT-54	Stabilizer set for Optima-serien	126 110.-
OT-56	Aluminium skruesett, selvgjengende	126 90.-
OT-57	Spesial støtdemper feste	126 48.-
OT-64	Spesial ving, forsølvet	126 82.-
OT-65	Vinge holder sett	127 72.-
OT-66	2 lav profil dekk 50 mmØ, Orig. T.Optima, Salute	127 124.-
OT-67	2 felger for lav profil dekk, 50 mmØ	127 76.-
OT-73	Støvfiltre (benyttes sammen med SC-40)	28.-
OT-75	Plugg for 8,4 Volt batteri	
OT-76	Herdet pinion drev	126 72.-
OT-90	Original MID-felg 50 mm lavprofil	127 76.-
OTW-1	Stabilisator stag for OPTIMA MID	127 110.-
OTW-2	Spesial FRP støtdemperfeste for OPTIMA MID	127 260.-
OTW-3	Spesial chassis for OPTIMA MID	127 260.-
PG-40	Fartsregulator, komplett m/motstand	158.-
PG-41	Fartsregulatorplate	56.-
PG-42	Kontaktpunkter for PG-40	34.-
PG-52	3-gear motstander (2x0.22 Ohm)	42.-
PI-15	2 kulelager, 80x120x3 mm	126 110.-
RK-2	Felg sett, par. Hvite eller svarte felger 50 mm	127 52.-
RK-15	1 par lav profil dekk 50 mm, blokktype	127 124.-
RK-30	Stabilizer set for Rocky-serien	126 134.-
RK-31	En-veis clutch for Rocky	126 286.-
SC-40	Støvhette for 540/550 motorer	40.-
SC-67	Fartsregulator, komplett u/motstand	138.-
SC-78	Fartsregulator, printplate	50.-
SC-79	Kontaktpunkter til fartsregulator	34.-
SC-80	4-gear motstander (3x0.15 Ohm)	72.-
SC-105	3-gear motstander (2x0.15 Ohm)	40.-
UM-17	Felger Ultima, 2 front 50 mm, 2 bak 50 mm	127 52.-
UM-23	Pinion gear 18 tenner	126 28.-
UM-24	Pinion gear 19 tenner	126 28.-
UM-25	Pinion gear 20 tenner	126 28.-
UM-26	Ultima FRP spesial støtdemperfeste	126 260.-
UM-27	Ultima spesial chassis	126 242.-
UM-28	Ultima motorbeskytter	126 84.-
UM-29	Ultima stabilizer sett	126 110.-
UM-30	Ultima FRP spesial radio plate	126 132.-
1878	Skrue låse lim, 2 tuber	22.-